

NC Specifications / FANUC Series

	Item	Specification	0i-TD
Controlled axis	Max. feed axes		4 AXIS
	Feed axes		X/Z/(Cs)
	Max. simultaneously controlled axis		4
	Least command increment	0.001mm / 0.0001"	○
Operation functions	Pulse handle feed	X1, X10, X100	○
	Feedrate per minute	G98	○
	Feedrate per revolution	G99	○
Interpolation functions	Linear interpolation	G01	○
	Circular interpolation	G02, G03	○
	Dwell	G04	○
	Polar coordinate interpolation	G12.1, G13.1	○
	Cylindrical interpolation	G70.1	○
	Variable lead thread cutting	G34	○
	Continuous threading		○
	Reference position return	G28	○
Feed function	Reference position return check	G27	○
	Rapid traverse rate override	F0, 25%, 50%, 100%	○
Spindle function	Feedrate override		0~150%
	Spindle orientation		○
Tool functions	Rigid tapping		○
	Tool number command	T4-Digt / T2-Digt	T4-Digt
	Tool nose radius compensation	G40 ~ G42	○
	Tool offset pairs		○
	Tool geometry/wear offset	GEOMETRY & WEAR DATA	○
	Tool life management		○
	Tool path graphic display		○
	Automatic tool offset	G36, G37	○
Program input	Direct input of tool offset value measured B		○
	Absolute/incremental programming		○
	Multiple repetitive cycle	G70 ~ G76	○
	Canned cycles	G90, G92, G94	○
	Inch/metric conversion	G20 / G21	○
	Program restart		○
	Retraction for rigid tapping		○
	Max. programmable dimension	±99999.999mm/±9999.9999"	○
	M function	M3 digit	○
	Custom macro		○
	Canned cycle for drilling		○
	Direct drawing dimension programming		○
	Programmable data input	G10	○
	Optional block skip		○
	Workpiece coordinate system	G52 ~ G59	○
Setting and display	Number of registerable programs		400EA
	Alarm & Operator history display	ALARM & OPERATION DISPLAY	○
	Run hour and parts count display	RUNNING TIME & PART NO. DISPLAY	○
	Display spindle & servo overload	SPINDLE & SERVO LOAD DISPLAY	○
	Self-diagnosis function		○
	Extended part program editing	COPY, MOVE, CHANGE OF NC PROGRAM	○
Data input/output	Display screen		10.4" color
	Memory card input/output		○
Editing operation	USB memory input/output		○
	Part program storage size	512Kbyte(1280m)	○
Manual guide i	Manual Guide i		○

SMEC

PL 45 series

CNC TURNING CENTER



SMEC
SMEC CO.,LTD.

SMEC Co., Ltd.

157-10, Goldenroot-ro, Juchon-myeon, Gimhae-si, Gyeongsangnam-do, Korea

Tel +82 55 340 4800 Fax +82 55 340 4740

http://www.esmec.com



SMEC
SMEC CO.,LTD.

- 1988 - Started as Samsung Heavy Industries Machine Tools Business
- 1989 - Horizontal and vertical machining center technology partnership with OKK Japan
- 1991 - Turning center and vertical machining center technology partnership with Mori Seiki
- 1996 - 5-sided processing center technology partnership with Toshiba
- 1999 - Spun out from Samsung Aerospace Industries and established SMEC Co., Ltd

SMEC

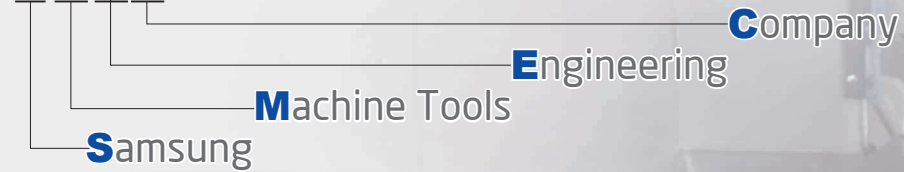

PL 45L
PL 45XL
PL 45LM
PL 45XLM

Strongest in class with superb structural design
Simultaneous heavy duty and precision turning

- 45 degree torque tube type bed to support heavy duty turning
- Significantly reduced non-cutting time and efficient turning
- Low-center of gravity reducing vibration, thermal deformation and improving rigidity

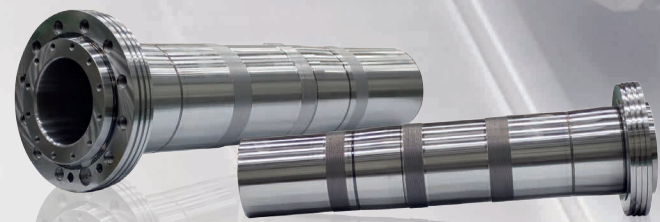

High Accuracy, High Rigidity Spindle

Pin Tube Rib Design for Minimal Axis Heat Transfer

Radiator fan-like pin tube rib design dissipates heat generated by axis movements, maintaining minimal thermal expansion.

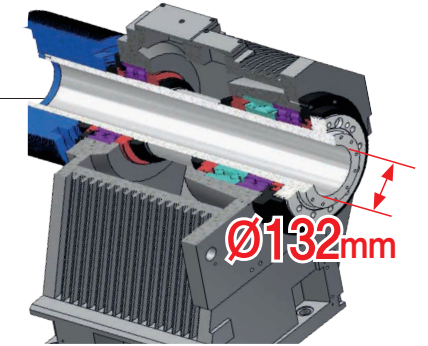

Output Converting Transmission

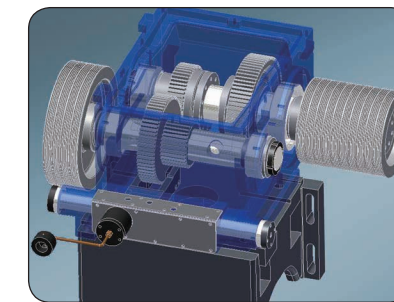

Equipped as standard feature, high Output Converting Transmission provides heavy-duty machining.

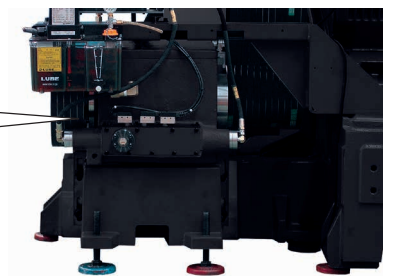

Spindle Power & Torque Diagram

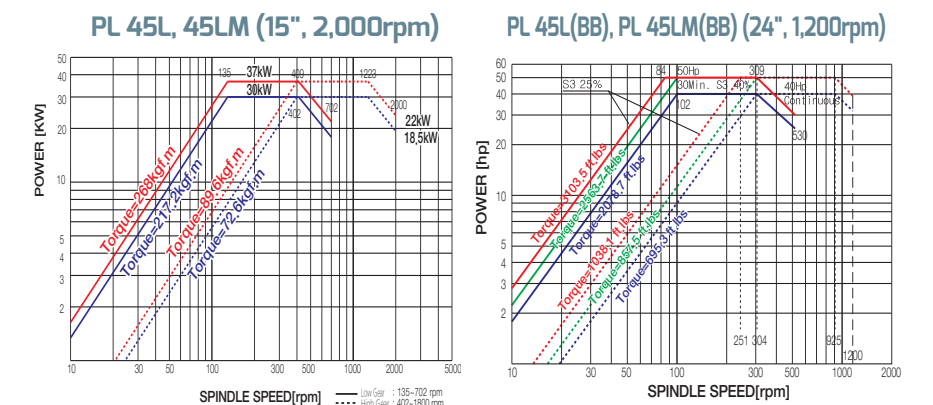

An innovative high precision, heavy duty CNC Lathe, integrated with all of SMEC's advanced technology - **PL 45 series**

Spindle speed
2,000 rpm
1,200 rpm (BB)

Spindle motor(30min/cont.)
37/30 kW

Rapid traverse(X/Z)
20/18 m/min (PL 45L/45LM)
20/10 m/min (PL 45XL/45XLM)

Feed motor(X/Z)
7/6 kW

Max. machining length
2,255 mm (PL 45LM)
3,000 mm (PL 45XLM)

Max. machining diameter
690 mm (PL 45)
620 mm (PL 45M)

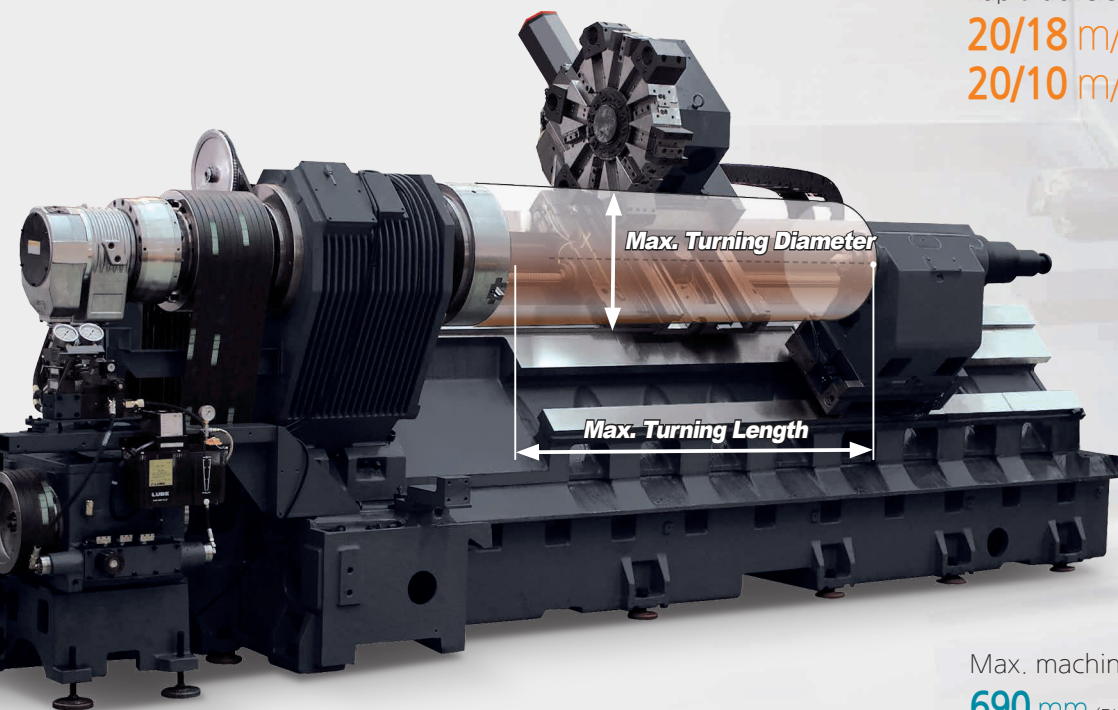

Highly Reliable and Rigid Structural Design

- One piece Meehanite casting with heavily ribbed torque tube design
- Rigid bed supports for powerful cutting
- Excellent vibration dampening and thermal displacement design

PL 45 (High Speed Hydraulic Turret)

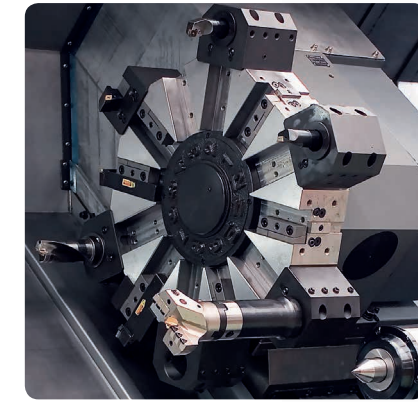

Indexing Time Number of tool positions
0.25 sec **12 stations**

High Speed, Heavy Duty Hyd. Index Turret

Driven by a high torque hydraulic index motor, the 10-station heavy-duty turret can accept tools on both left and right side of each station. Turret indexing (repeatability ± 0.005) is non-stop, bi-directional with a fast 0.25 second next station index time. A large diameter ($\varnothing 250$) Curvic coupling with 6,377kgf clamping force enables precision as well as heavy-duty cutting.

PL 45LM (BMT High Speed Turret)

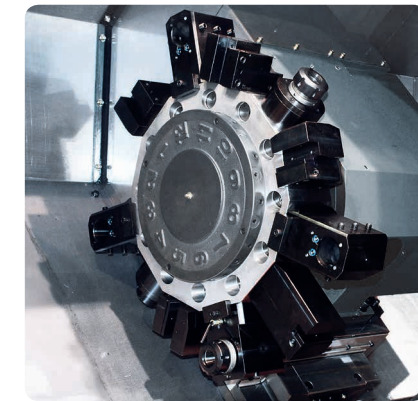

Indexing Time Number of tool positions Milling Spindle Speed Tool Holder
0.25 sec **12 stations** **4,000 rpm** **BMT 75**

BMT Milling Turret (M Type)

PL45LM is equipped with standard 12-station BMT turret capable of accepting rotary tools at any station, providing flexible machining thru various machining operations in just one set-up. Each BMT holder is securely tightened by 4 screws, allowing the turret to perform heavy-duty cutting, milling and drilling operations. Turret indexing is non-stop, bi-directional with a fast 0.25second next station index time.

Turret Torque Diagram

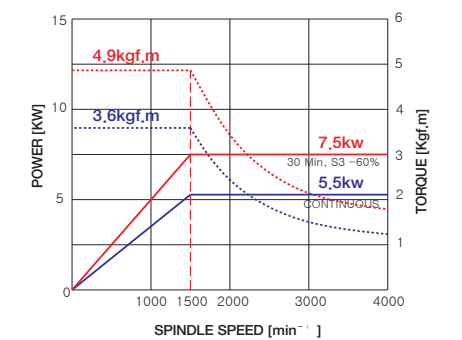



Centralized Operation Panel

The centralized operation panel with its 10.4 inch color TFT LCD monitor is able to swivel 90 degrees, providing operators with easy access to the control panel while working on the machine.

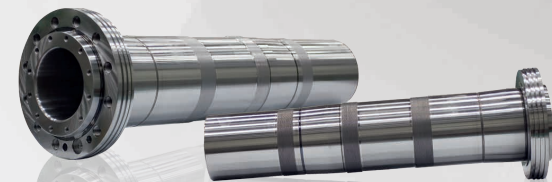

Rigid 45 degree Slant Bed

45 degree slant torque tube design bed and wide guide slide way ensure long term rigidity and machining accuracy. Also, the Slant Type structure allows for easier access to the workpiece and superb chip discharge.

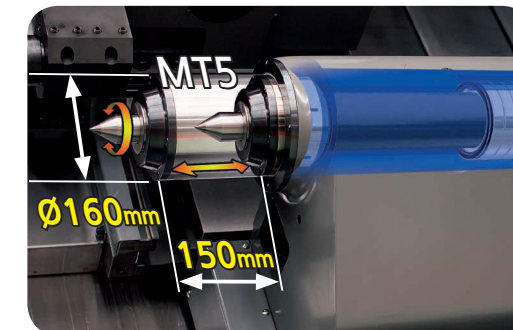
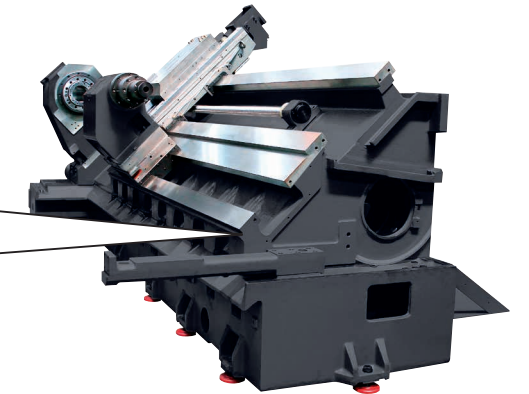
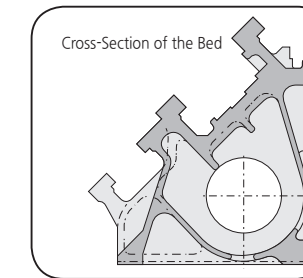

Programmable Tailstock (Carriage direct-coupled) [Std.]

The programmable tailstock body mounted is on wide guide ways to ensure rigid work piece support.

Pre-tensioned and Double Anchored Ballscrews

All axes ballscrews are pre-tensioned, heat treated and fixed by double anchors on both ends, providing ultimate rigidity and minimal thermal growth.

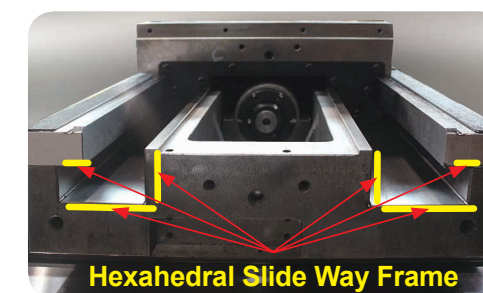
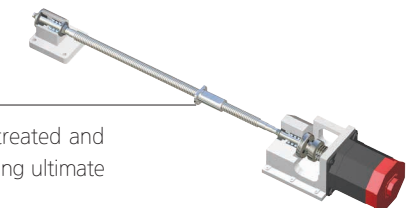

Hexahedral Slide Way Frame (X-axis)

Wide integral way is machined from the casting, induction hardened and precision ground to ensure long-term rigidity, machining accuracy and heavy-duty machining.

High Precision

Surface Roughness

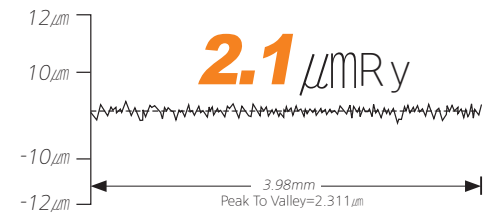

Model : PL 45

Roundness

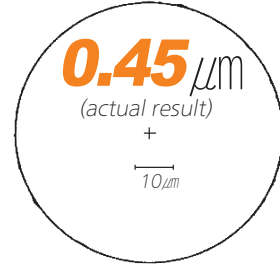

Cutting condition	
Tool	Diamond tool <nose radius 0.5mm>
Material	AL150<Aluminum>
Cutting speed	230 m/min
Feedrate	0.05 mm/rev
Depth of cut	0.1 mm
Outer diameter	200 mm
Filter	1-50

Processing Speed

Turning Performance (material:SM45C) PL 45LM

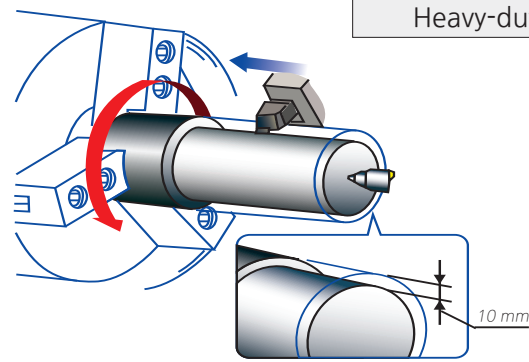

Heavy-duty cutting (O.D) <32mm×32mm qualified tool>

Spindle speed
367 rpm
Cutting speed
150 m/min
Depth of cut
10 mm <Spindle Load 65%>
Feedrate
0.4 mm/rev

Standard Accessories

Optional Accessories

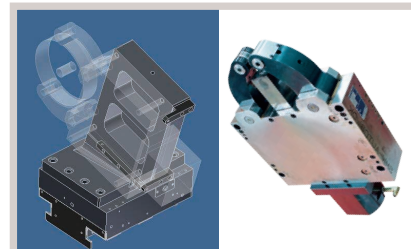
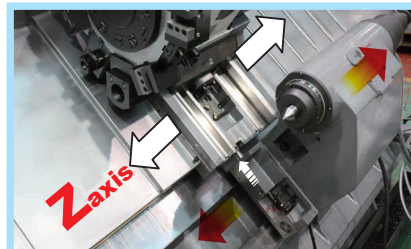
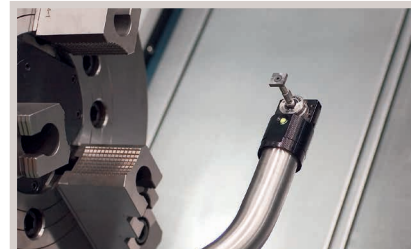
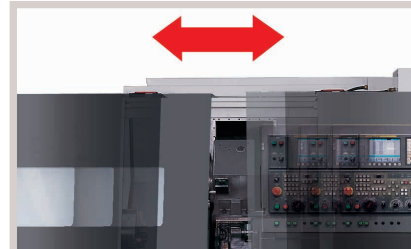

Tooling System

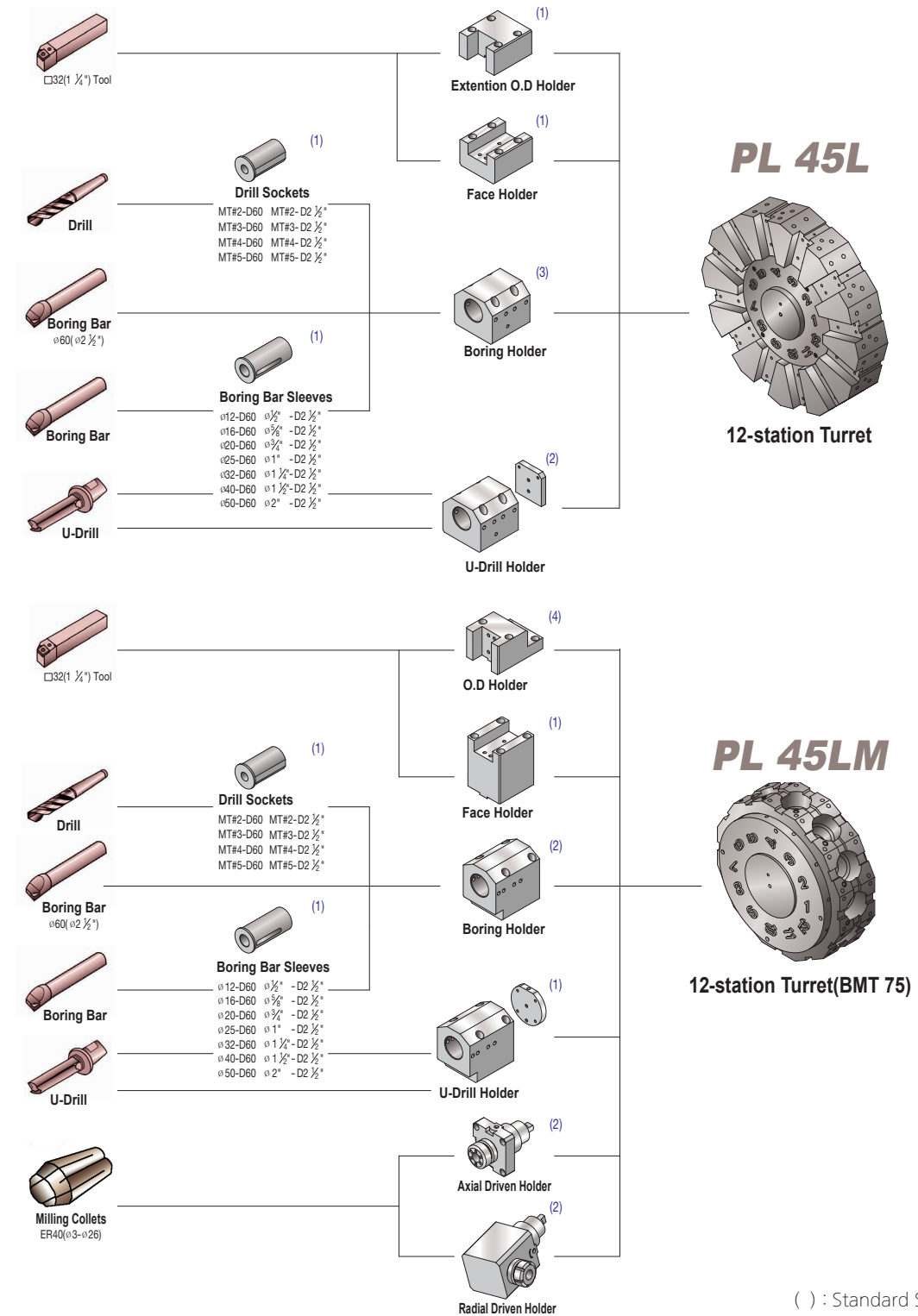

() : Standard Set Numbers

