



Conventional Horizontal Boring & Milling Machine
UBM series

CNC Horizontal Boring & Milling Machine (FIXED COLUMN)
UBM-RS series

CNC Horizontal Machining Center
UHM series

CNC Horizontal Heavy Duty Milling Machine
UMM series

CNC Horizontal Boring & Milling Machine (MOVABLE COLUMN)
UBM-R series



UDM
series



CNC Double Column Machining Center

UDM SERIES (Small Model) CNC DOUBLE COLUMN MACHINING CENTER

- Range of X-axis travel: **2200~3200mm**.
- Two linear guide ways on base (X-axis).
- Two linear guide ways on Y-axis with two blocks on each linear guide way.
- Box ways on Z-axis.
- Both columns and the cross beam cast in one single piece.
- BT50, 6000rpm gear-drive spindle.



One piece structure (cross beam & column)



Full casting structure

MACHINE SPECIFICATIONS

UDM-XXXX A (x100mm) : X-Axis Travel
 B (x100mm) : Y-Axis Travel
 (): As Optional

MODLE		UNIT	UDM-2212	UDM-2215	UDM-3212	UDM-3215
TABLE	Table Size	mm	2000 x 1100	2000 x 1300	3000 x 1100	3000 x 1300
	T-slots Size	mm	22			
	Maximum Load	kg	3500	4000	4500	5000
TRAVEL	X-Axis	mm	2200	2200	3200	3200
	Y-Axis	mm	1200	1500	1200	1500
	Z-Axis	mm	760			
SPINDLE	Spindle Servo Motor - cont. / 30min.	kW	11/15 (22/26)			
	Speed	rpm	6000			
	Taper		7/24 Taper, ISO.50, BT-50			
DISTANCES	Between Two Columns	mm	1300	1500	1300	1500
	Spindle Nose to Table Surface	mm	200 ~ 960			
FEED RATE	Rapid Feed Rate X / Y / Z	m/min	20 / 20 / 15			
	Minimum Setting	mm/min	0.001			
	Cutting Feed Rate	m/min	8			
ATC	No. of Tools	pieces	0 (24 / 32 / 40)			
	Tool Change Time - T to T (approx.)	sec	8 (Arm Type)			
	Max. Tool-Diameter / Length	mm	Ø125/Ø200 (Without Adjacent Tool) / Length 350			
	Max. Tool Weight	kg	15			
COOLANT & LUBRICATION	Coolant Tank Volume	L	240			
	Hydraulic Tank Volume	L	70			
	Lubrication Tank Volume	L	8			
MISCELLANEOUS	Power Required	kVA	40			
	Pressurized Air	kg/cm ²	5 ~ 8			
	Hydraulics Required	kg/cm ²	70			
	Machine Weight (approx.)	kg	17000	17500	21000	21500
	Controller		FANUC Oi MF (FANUC 32i-B/31i-B) (MITSUBISHI, SIEMENS, HEIDENHAIN)			

■ Specifications are subject to change without prior notice.

STANDARD ACCESSORIES :

1. Glass window type splash guard
2. Programmable coolant system
3. Automatic lubrication system
4. Spindle air blast system
5. Working lamp
6. Alarm lamp for abnormal situations
7. Indication lamp for dwell & end of job
8. Leveling bolts & pads
9. Chip auger & chain type chip conveyors
10. Toolbox with spanners & wrenches
11. M.P.G
12. Machine inspection lists
13. Operation manuals
14. Controller manuals and circuit diagram
15. Auto power off
16. RS-232C terminal interface
17. Spindle coolant system
18. Hydraulic system
19. Heat exchanger
20. FANUC Oi MF Controller

OPTIONAL ACCESSORIES :

1. 8000RPM direct drive spindle (35HP)
2. X, Y and Z axes with linear scales
3. Auto. tool length & diameter measurement (TS-27R)
4. CNC rotary table
5. ATC: 24, 32, 40 tools
6. Coolant through spindle
7. Oil-feed holder
8. Oil mist device
9. Air conditioner for electrical cabinet
10. FANUC 32i-B (31i-B) Controller
11. MITSUBISHI Controller
12. SIEMENS Controller
13. HEIDENHAIN Controller
14. 12000RPM or 15000RPM direct drive spindle-BBT 40 (only for FANUC or MITSUBISHI controller)

UDM series

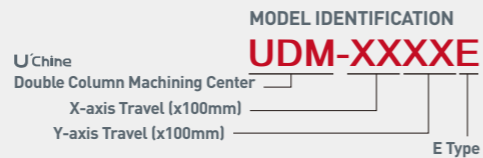

UDM SERIES (E Type)

CNC DOUBLE COLUMN MACHINING CENTER

- Range of X-axis travel: **2200~6200mm** {door widths 1900 (2000), 2400 (2500), 2800mm}.
- Two linear guide ways on base (X-axis) (M55 roller type).
- Two linear guide ways on Y-axis (M65 roller type. Two blocks on each linear guide way).
- Box ways on Z-axis (Linear guide ways on Z-axis are optional. M65 roller type. Two blocks on each linear guide way).
- Step type beam construction (bridge type).
- Contact face length between the saddle and spindle head is 970mm.
- BT50, 4000rpm (6000, 8000rpm) gear-drive spindle.

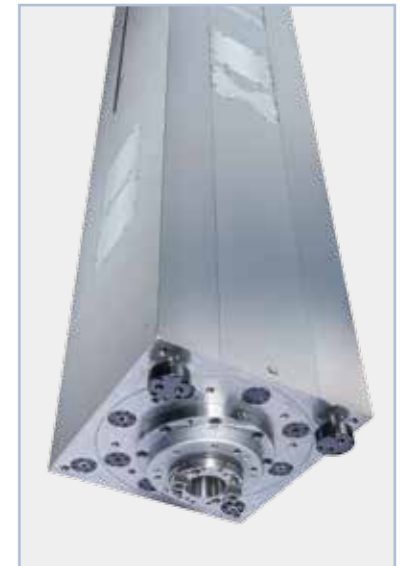

Available to equip with a highly rigid square ram type spindle head on Z-axis (optional).



Available to mount with linear guideways on Z-axis and use direct-drive high speed spindle (8,000~15,000 rpm) (optional).

UDM SERIES

CNC Double Column Machining Center (E Type)

MACHINE SPECIFICATIONS

UDM-XXXX A (x100mm): X-Axis Travel B (x100mm): Y-Axis Travel (): As Optional

MODEL		UNIT	UDM-2218E	UDM-2718E	UDM-3218E	UDM-3718E	UDM-4218E	UDM-2223E	UDM-2723E	UDM-3223E	UDM-3723E	UDM-4223E	UDM-5223E	UDM-6223E	UDM-3228E	UDM-3728E	UDM-4228E	UDM-5228E	UDM-6228E		
TABLE	Table Size	mm	2000x1500	2500x1500	3000x1500	3500x1500	4000x1500	2000x2100	2500x2100	3000x2100	3500x2100	4000x2100	5000x2100	6000x2100	3000x2100	3500x2100	4000x2100	5000x2100	6000x2100		
	T-slots Size	mm	22									22									
	Maximum Load	tons	8	9	10	11	12	10	11	12	12	13	14	15	12	12	13	14	15		
TRAVEL	X-Axis	mm	2200	2700	3200	3700	4200	2200	2700	3200	3700	4200	5200	6200	3200	3700	4200	5200	6200		
	Y-Axis	mm	1800				2300 (2800)				2300 (2800)				2800 (3200)						
	Z-Axis	mm	1000									1000									
SPINDLE	Spindle Servo Motor - cont. / 30min.	kW	15/18.5 (22/26)									15/18.5 (22/26)									
	Speed	rpm	6000 (4000)									6000 (4000)									
	Taper		7/24 Taper ISO.50, BT-50									7/24 Taper ISO.50, BT-50									
DISTANCES	Between Two Columns	mm	1900 (2000)				2400 (2500)				2400 (2500)				2800						
	Spindle Nose to Table Surface	mm	200~1200									200~1200									
FEED RATE	Rapid Feed Rate X/Y/Z	m/min	15 / 15 / 12 (24 / 24 / 20 Z-Axis Linear Guide Way)									15 / 15 / 12	12 / 15 / 12			15 / 15 / 12			12 / 15 / 12		
	Minimum Setting	mm/min	0.001									0.001									
	Cutting Feed Rate	mm/min	1~8000									1~8000									
ATC	No. of Tools	pieces	0 (24 / 32 / 40)									0 (24 / 32 / 40)									
	Tool Change Time - T to T (approx.)	sec	8 (Arm Type)									8 (Arm Type)									
	Max. Tool-Diameter / Length	mm	Ø125/Ø200 (Without Adjacent Tool) / Length 350									Ø125/Ø200 (Without Adjacent Tool) / Length 350									
	Max. Tool Weight	kg	15									15									
COOLANT & LUBRICATION	Coolant Tank Volume	L	450				640				640										
	Hydraulic Tank Volume	L	70									70									
	Lubrication Tank Volume	L	8									8									
MISCELLANEOUS	Power Required	kVA	50									55									
	Pressurized Air	kg/cm ²	7									7									
	Hydraulics Required	kg/cm ²	70									70									
	Machine Weight (approx.)	tons	24	27	30	32	34	27	29	31	33	35	39	43	33	35	39	43	50		
Controller		FANUC 0iMF (32i-MB/31i-MB) (MITSUBISHI) (SIEMENS) (HEIDENHAIN)									FANUC 0iMF (32i-MB/31i-MB) (MITSUBISHI) (SIEMENS) (HEIDENHAIN)										

■ Specifications are subject to change without prior notice.

■ There are new types UDM-3718E, 3723E, 3728E.

STANDARD ACCESSORIES :

- Glass window type splash guard
- Programmable coolant system
- Automatic lubrication system
- Spindle air blast system
- Work lamp
- Alarm lamp for abnormal situations
- Indication lamp for dwell & end of job
- Leveling bolts & pads
- Chip auger & chain type chip conveyor
- Toolbox with spanners & wrenches
- M.P.G
- Machine inspection lists
- Operation manuals
- Controller manuals and circuit diagram
- Auto power off
- RS-232C terminal interface
- Spindle coolant system
- Hydraulic system
- Heat exchanger
- FANUC 0i MF Controller

OPTIONAL ACCESSORIES :

- 8000RPM direct drive spindle (35HP)
- X, Y and Z axes with linear scales
- Auto. tool length & diameter measurement (TS-27R)
- CNC rotary table
- ATC: 24, 32, 40 tools
- Coolant through spindle
- Oil-feed holder
- Oil mist device
- Air conditioner for electrical cabinet
- FANUC 32i-B (31i-B) Controller
- MITSUBISHI Controller
- SIEMENS Controller
- HEIDENHAIN Controller
- 12000RPM or 15000RPM direct drive spindle-BBT 40 (only for FANUC or MITSUBISHI controller)

UDM series

U'Chine
Double Column Machining Center
X-axis Travel (x100mm)
Y-axis Travel (x100mm)

MODEL IDENTIFICATION
UDM-XXXX

UDM SERIES

(Two Linear Guide Ways on X-axis)

CNC DOUBLE COLUMN MACHINING CENTER

- Range of X-axis travel: **2200~6200mm**.
- Two linear guide ways on base (X-axis).
- Two linear guide ways on Y-axis with three blocks on each linear guide way.
- Box ways on Z-axis.
- Step type beam construction.
- BT50, 4000rpm gear-drive spindle.

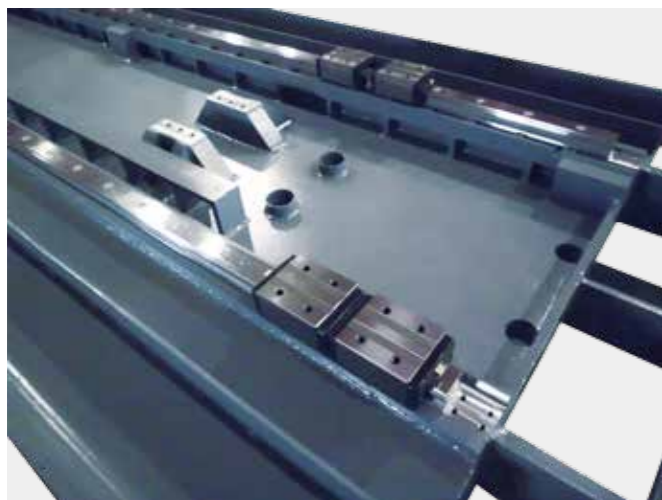

Two Linear Guide Ways on X-axis



UDM SERIES

CNC Double Column Machining Center (Two Linear Guide Ways)

MACHINE SPECIFICATIONS

UDM-XXXX A (x100mm) : X-Axis Travel B (x100mm) : Y-Axis Travel () : As Optional

MODEL		UNIT	UDM-2216	UDM-2616	UDM-3216	UDM-4216	UDM-2221	UDM-2621	UDM-3221	UDM-4221	UDM-5221	UDM-3226	UDM-3228	UDM-4226	UDM-4228	UDM-5226	UDM-5228	UDM-6221	UDM-6226	UDM-6228	
TABLE	Table Size	mm	2000x1400	2400x1400	3000x1400	4000x1400	2000x1800	2400x1800	3000x1800	4000x1800	5000x1800	3000x2200	3000x2500	4000x2200	4000x2500	5000x2200	5000x2500	6000x1800	6000x2000	6000x2500	
	T-slots Size	mm	22									22									
	Maximum Load	tons	6	8	9	10	8	9	10	12	15	12	14	18	18	20	22	22			
TRAVEL	X-Axis	mm	2200	2600	3200	4200	2200	2600	3200	4200	5200	3200	4200	5200	5200	6200	6200	6200			
	Y-Axis	mm	1600				2100				2100		2600	3200	2600	3200	2600	3200	2100	2600	3200
	Z-Axis	mm	800 (1000, 1200)									800 (1000, 1200)									
SPINDLE	Spindle Servo Motor - cont. / 30min.	kW	15/18.5 (22/26)									15/18.5 (22/26)									
	Speed	rpm	4000 (6000)									4000 (6000)									
	Taper		7/24 Taper ISO.50, BT-50									7/24 Taper ISO.50, BT-50									
DISTANCES	Between Two Columns	mm	1600				2100				2100	2600	2800	2600	2800	2600	2800	2100	2600	2800	
	Spindle Nose to Table Surface	mm	200~1000 (200~1200, 200~1400)									200~1000 (200~1200, 200~1400)									
FEED RATE	Rapid Feed Rate X/Y/Z	m/min	12 / 12 / 10									12 / 12 / 10						10 / 12 / 10			
	Minimum Setting	mm/min	0.001									0.001									
	Cutting Feed Rate	mm/min	1~5000									1~5000									
ATC	No. of Tools	pieces	(24 / 32 / 40 / 60)									(24 / 32 / 40 / 60)									
	Tool Change Time - T to T (approx.)	sec	8 (Arm Type)									8 (Arm Type)									
	Max. Tool-Diameter / Length	mm	Ø125/Ø200 (Without Adjacent Tool) / Length 350									Ø125/Ø200 (Without Adjacent Tool) / Length 350									
	Max. Tool Weight	kg	18									18									
COOLANT & LUBRICATION	Coolant Tank Volume	L	450				640	450	640	640		700	680	700	750	700	750	700			
	Hydraulic Tank Volume	L	70				80	70	80	80											
	Lubrication Tank Volume	L	8									8									
MISCELLANEOUS	Power Required	kVA	50									50									
	Pressurized Air	kg/cm ²	7									7									
	Hydraulics Required	kg/cm ²	70									70									
	Machine Weight (approx.)	tons	26	28	30	33	27	25	31	35	38.5	38.5	43	43	48	49	54	44	50	60	
Controller		FANUC 0iMF (32i-B/31i-B) (MITSUBISHI) (SIEMENS) (HEIDENHAIN)									FANUC 0iMF (32i-B/31i-B) (MITSUBISHI) (SIEMENS) (HEIDENHAIN)										

■ Specifications are subject to change without prior notice.

STANDARD ACCESSORIES :

- Glass window type splash guard
- Programmable coolant system
- Automatic lubrication system
- Spindle air blast system
- Work lamp
- Alarm lamp for abnormal situations
- Indication lamp for dwell & end of job
- Leveling bolts & pads
- Chip auger & chain type chip conveyor
- Toolbox with spanners & wrenches
- M.P.G
- Machine inspection lists
- Operation manuals
- Controller manuals and circuit diagram
- Auto power off
- RS-232C terminal interface
- Spindle coolant system
- Hydraulic system
- Heat exchanger
- FANUC 0i MF Controller

OPTIONAL ACCESSORIES :

- Auxiliary work table
- CNC rotary table
- ATC: 24, 32, 40, 60 tools
- Auto. tool length & diameter measurement (TS-27R)
- Work piece coordinate measuring (OMP 60)
- Various milling heads are available
- Linear scales
- Coolant through spindle
- Oil-feed holder
- Oil mist device
- Programmable coolant nozzle
- Air conditioner for electrical cabinet
- Auto heat compensation
- Z-axis linear guide ways and direct-drive high speed spindle (800rpm) (or BBT-40, 12000rpm, 15000rpm)
- Square ram on Z-axis

UDM series

U'Chine
Double Column Machining Center
X-axis Travel (x100mm)
Door Width (x100mm)

MODEL IDENTIFICATION
UDM-XXXX

UDM SERIES

(Three Linear Guide Ways on X-axis)

CNC DOUBLE COLUMN MACHINING CENTER

- Range of X-axis travel: **4200~8200mm.**
- Three linear guide ways on base (X-axis).
- Two linear guide ways on Y-axis with three blocks on each linear guide way.
- Box ways on Z-axis.
- Step type beam construction.
- BT50, 4000rpm gear-drive spindle.



Three Linear Guide Ways on X-axis



UDM SERIES

CNC Double Column Machining Center (Three Linear Guide Ways)

MACHINE SPECIFICATIONS

UDM-XXXX A B A (x100mm) : X-Axis Travel B (x100mm) : Door Width () : As Optional

MODEL		UNIT	UDM-4228B	UDM-5228B	UDM-6228B	UDM-4232	UDM-5232	UDM-6232	UDM-7232	UDM-4236	UDM-5236	UDM-6236	UDM-7236	UDM-7232B	UDM-7236B	UDM-8232B	UDM-8236B
TABLE	Table Size	mm	4000x2500	5000x2500	6000x2500	4000x2900	5000x2900	6000x2900	6000x2900	4000x3000	5000x3000	6000x3000	6000x3000	7000x2900	7000x3000	8000x2900	8000x3000
	T-slots Size	mm	22						22								
	Maximum Load	tons	16	20	24	16	20	24	24	16	20	24	24	24			
TRAVEL	X-Axis	mm	4200	5200	6200	4200	5200	6200	7200	4200	5200	6200	7200	7200	7200	8200	8200
	Y-Axis	mm	3200			3600			3600	4000			3600	4000	3600	4000	
	Z-Axis	mm	1000 (1200, 1400 Square Ram)						1000 (1200, 1400 Square Ram)								
SPINDLE	Spindle Servo Motor - cont. / 30min.	kW	15/18.5 (22/26)						15/18.5 (22/26)								
	Speed	rpm	4000 (6000)						4000 (6000)								
	Taper		7/24 Taper ISO.50, BT-50						7/24 Taper ISO.50, BT-50								
DISTANCES	Between Two Columns	mm	2800			3200			3200	3600			3200	3600	3200	3600	
	Spindle Nose to Table Surface	mm	200~1200 (200~1400, 200~1600)						200~1200 (200~1400, 200~1600)								
FEED RATE	Rapid Feed Rate X / Y / Z	m/min	10 / 12 / 10						10 / 12 / 10								
	Minimum Setting	mm/min	0.001						0.001								
	Cutting Feed Rate	mm/min	1~5000						1~5000								
ATC	No. of Tools	pieces	{ 24 / 32 / 40 / 60 }						{ 24 / 32 / 40 / 60 }								
	Tool Change Time - T to T (approx.)	sec	8 (Arm Type)						8 (Arm Type)								
	Max. Tool-Diameter / Length	mm	Ø125/Ø200 (Without Adjacent Tool) / Length 350						Ø125/Ø200 (Without Adjacent Tool) / Length 350								
	Max. Tool Weight	kg	18						18								
COOLANT & LUBRICATION	Coolant Tank Volume	L	700						700	750			700	750	700	750	
	Hydraulic Tank Volume	L	80						80								
	Lubrication Tank Volume	L	8						8								
MISCELLANEOUS	Power Required	kVA	50						50								
	Pressurized Air	kg/cm ²	7						7								
	Hydraulics Required	kg/cm ²	70						70								
	Machine Weight (approx.)	tons	48	54	60	55	62	68	75	58	64	72	82	75	80	80	85
Controller		FANUC 0iMF (32i-B/31i-B) (MITSUBISHI) (SIEMENS) (HEIDENHAIN)						FANUC 0iMF (32i-B/31i-B) (MITSUBISHI) (SIEMENS) (HEIDENHAIN)									

■ Specifications are subject to change without prior notice.

STANDARD ACCESSORIES :

- Glass window type splash guard
- Programmable coolant system
- Automatic lubrication system
- Spindle air blast system
- Work lamp
- Alarm lamp for abnormal situations
- Indication lamp for dwell & end of job
- Leveling bolts & pads
- Chip auger & chain type chip conveyor
- Toolbox with spanners & wrenches
- M.P.G
- Machine inspection lists
- Operation manuals
- Controller manuals and circuit diagram
- Auto power off
- RS-232C terminal interface
- Spindle coolant system
- Hydraulic system
- Heat exchanger
- FANUC 0i MF Controller

OPTIONAL ACCESSORIES :

- Auxiliary work table
- CNC rotary table
- ATC: 24, 32, 40, 60 tools
- Auto. tool length & diameter measurement (TS-27R)
- Work piece coordinate measuring (OMP 60)
- Various milling heads are available
- Linear scales
- Coolant through spindle
- Oil-feed holder
- Oil mist device
- Programmable coolant nozzle
- Air conditioner for electrical cabinet
- Auto heat compensation
- Z-axis linear guide ways and direct-drive high speed spindle (800rpm) (or BBT-40, 12000rpm, 15000rpm)
- Square ram on Z-axis

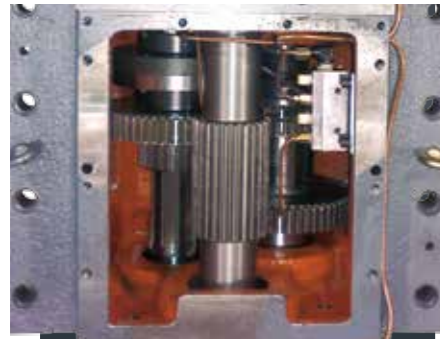

Gearbox Type Spindle Head

The $\varnothing 100\text{mm}$ spindle is driven by a $\alpha 22$ spindle motor and transmitted through a gearbox, providing maximum speed 6000rpm and 755N-m of torque output. This makes the machine ideal for both high speed and heavy cutting applications. When a 4000rpm is used, torque output may reach 1132N-m for extra powerful cutting operation.

Step type linear guide ways layout.

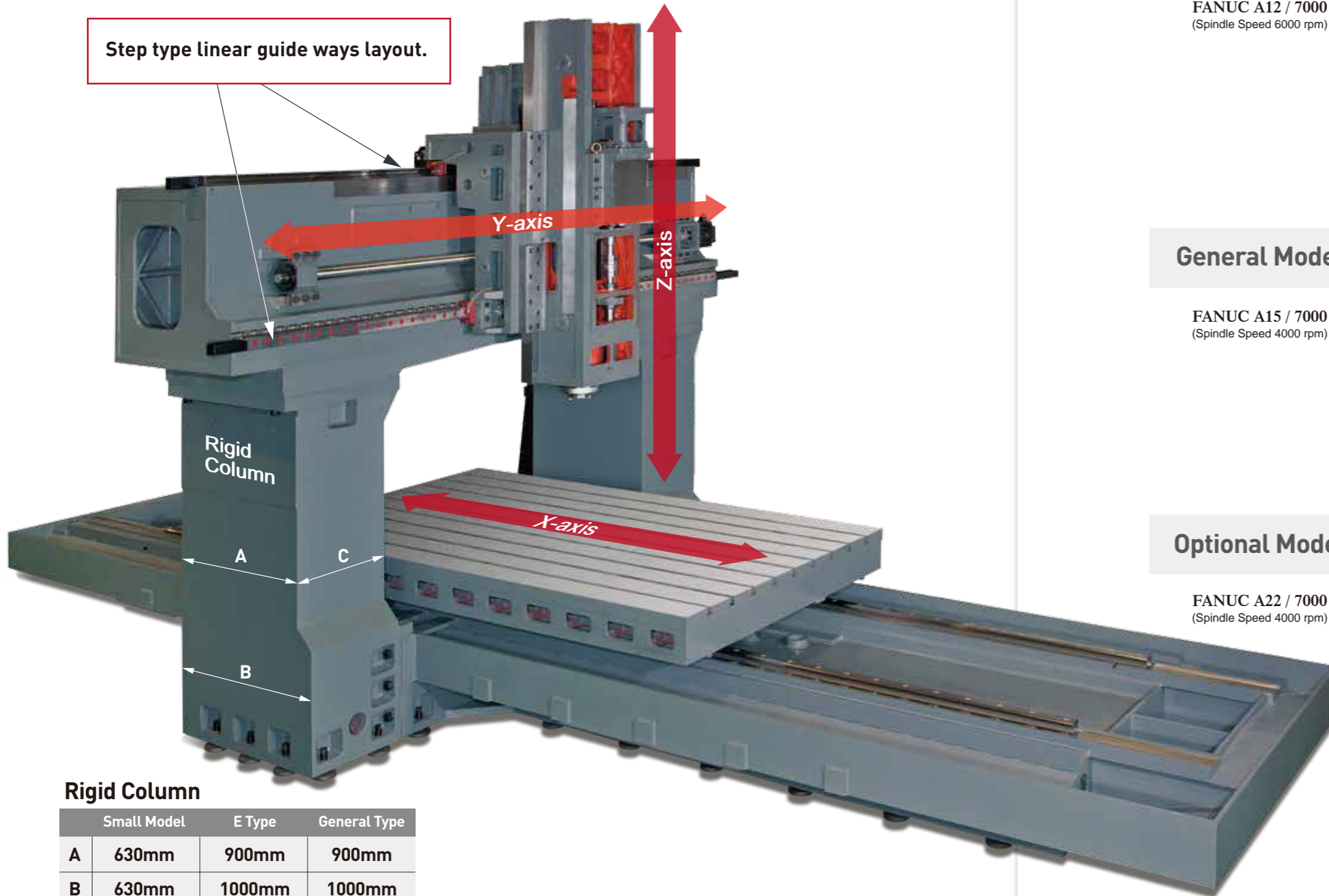

Rigid Column

	Small Model	E Type	General Type
A	630mm	900mm	900mm
B	630mm	1000mm	1000mm
C	350mm	480mm	550mm

Spindle Speed / Torque Diagram

UDM series

Small Model

FANUC A12 / 7000
(Spindle Speed 6000 rpm)

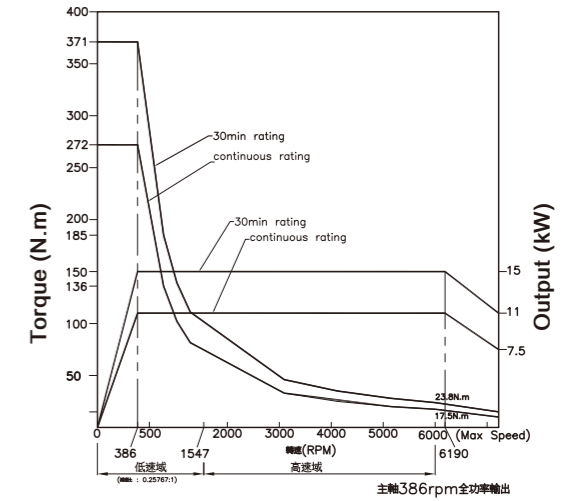

General Model

FANUC A15 / 7000
(Spindle Speed 4000 rpm)

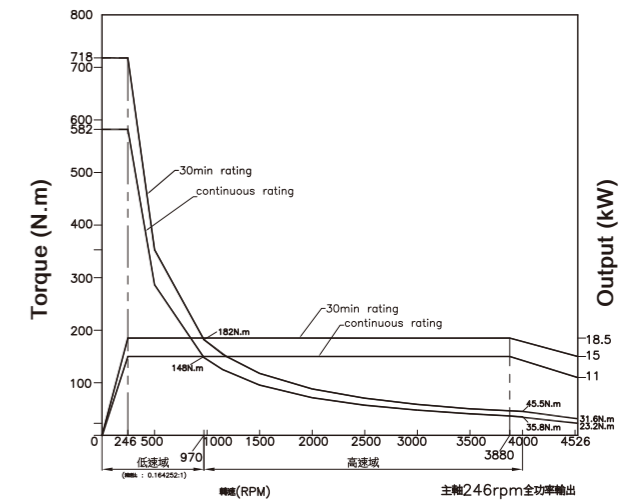

Optional Model

FANUC A22 / 7000
(Spindle Speed 4000 rpm)

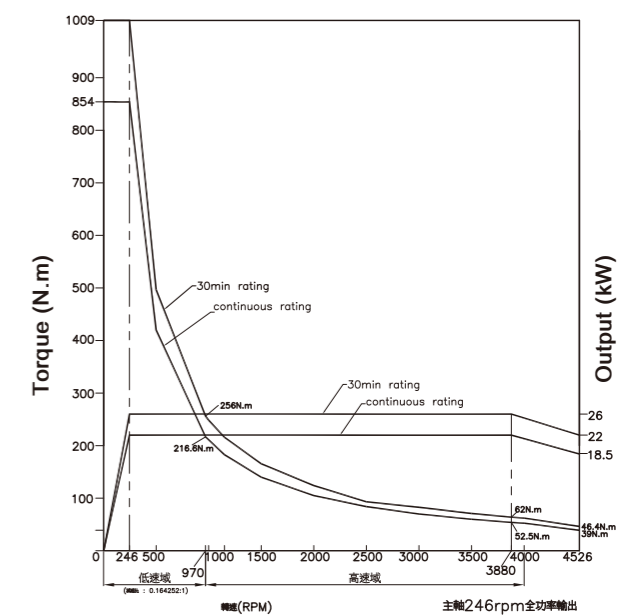

Step Type Beam for Improved Cutting Stability

The oversized beam is a step type construction, that allows for better stability of cutting.

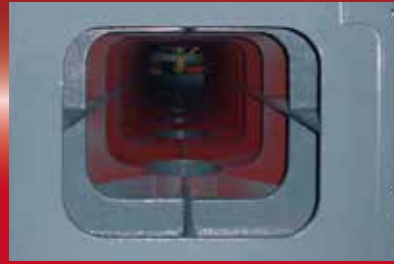

Scientifically Rib Reinforced Beam

The oversized beam in combination with scientific rib reinforcement in the beam interior helps to maximize structural rigidity, and provide a solid support for the spindle head.

65mm Roller Type Linear Guide Ways on Column (Y-axis)

The Y-axis is mounted with 65mm roller type linear guide ways. Each linear guide way (upper and lower) is equipped with three blocks respectively for increased rigidity of the spindle head.

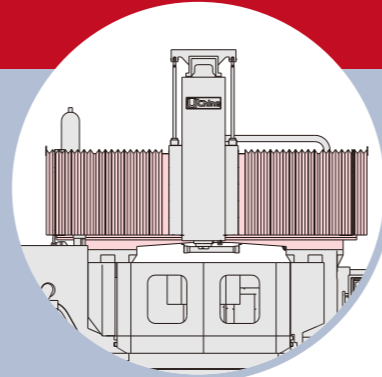

Hydraulic Counter-balance on Z-axis

The Z-axis movement is counter-balanced by two hydraulic cylinders, ensuring outstanding smoothness and stability of Z-axis movement.

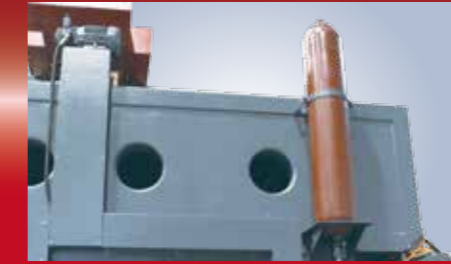

Accumulator

The accumulator is used to supply pressure source to the hydraulic cylinders, allowing the Z-axis to move smoothly.

Directly Coupled To Ball Screw

The servo motor on the Y-axis is directly coupled to the ball screw with a coupling, that eliminates backlash while achieving high transmission accuracy.

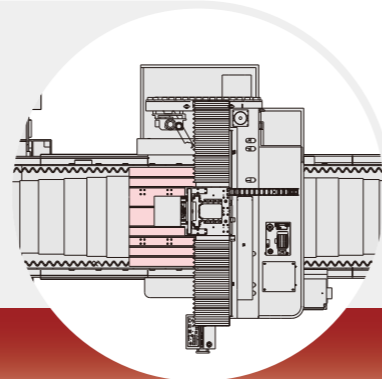
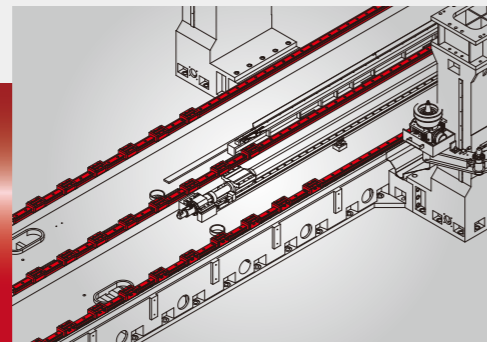
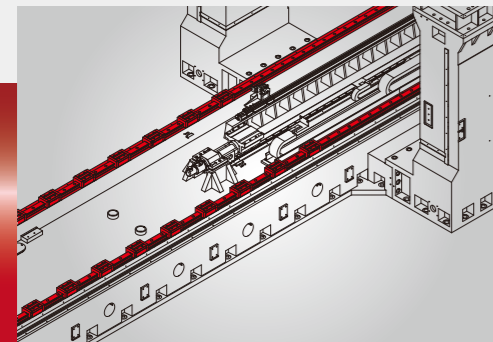
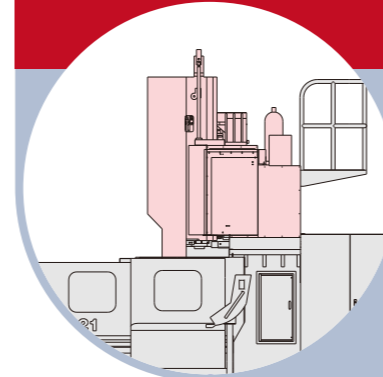

Two Linear Guide Ways on The Base (X-axis)

- Depending on table width, the machine base will be mounted with two or three linear guide ways.
- The X-axis is mounted with 65mm ball type linear guide ways, featuring low friction and making it ideal for heavy workpiece machining.

Three Linear Guide Ways on The Base (X-axis)

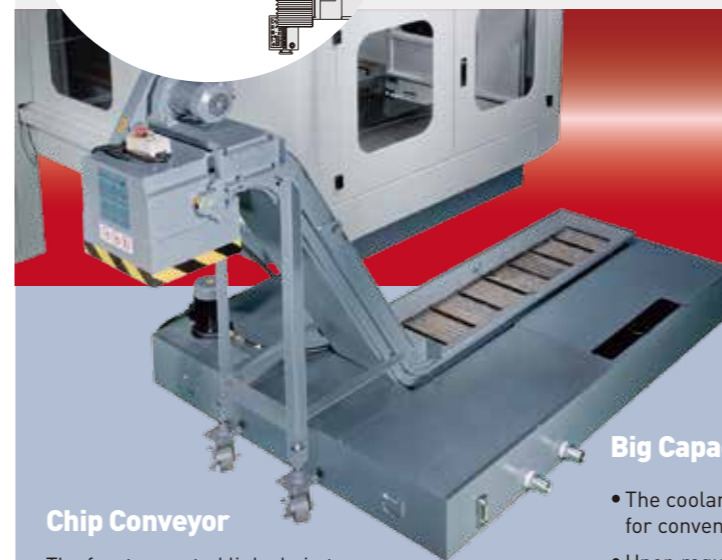
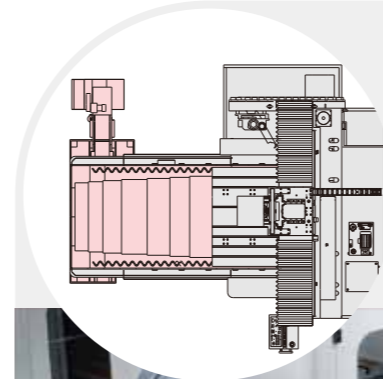

Chip Conveyor

The front mounted link chain type chip conveyor collects the chips from the chip augers for delivering chips out of the machine.

Big Capacity

- The coolant tank can be moved out for convenient cleaning.
- Upon request, an oil coolant separation device is available to prevent cutting fluid from deterioration. [Optional]



Two Chip Augers on Base

The right and left side of base are equipped with two chip augers for delivering chips to the front mounted link chain type chip conveyor. These chip augers enable the machine to keep clean during cutting.

Optional Accessories

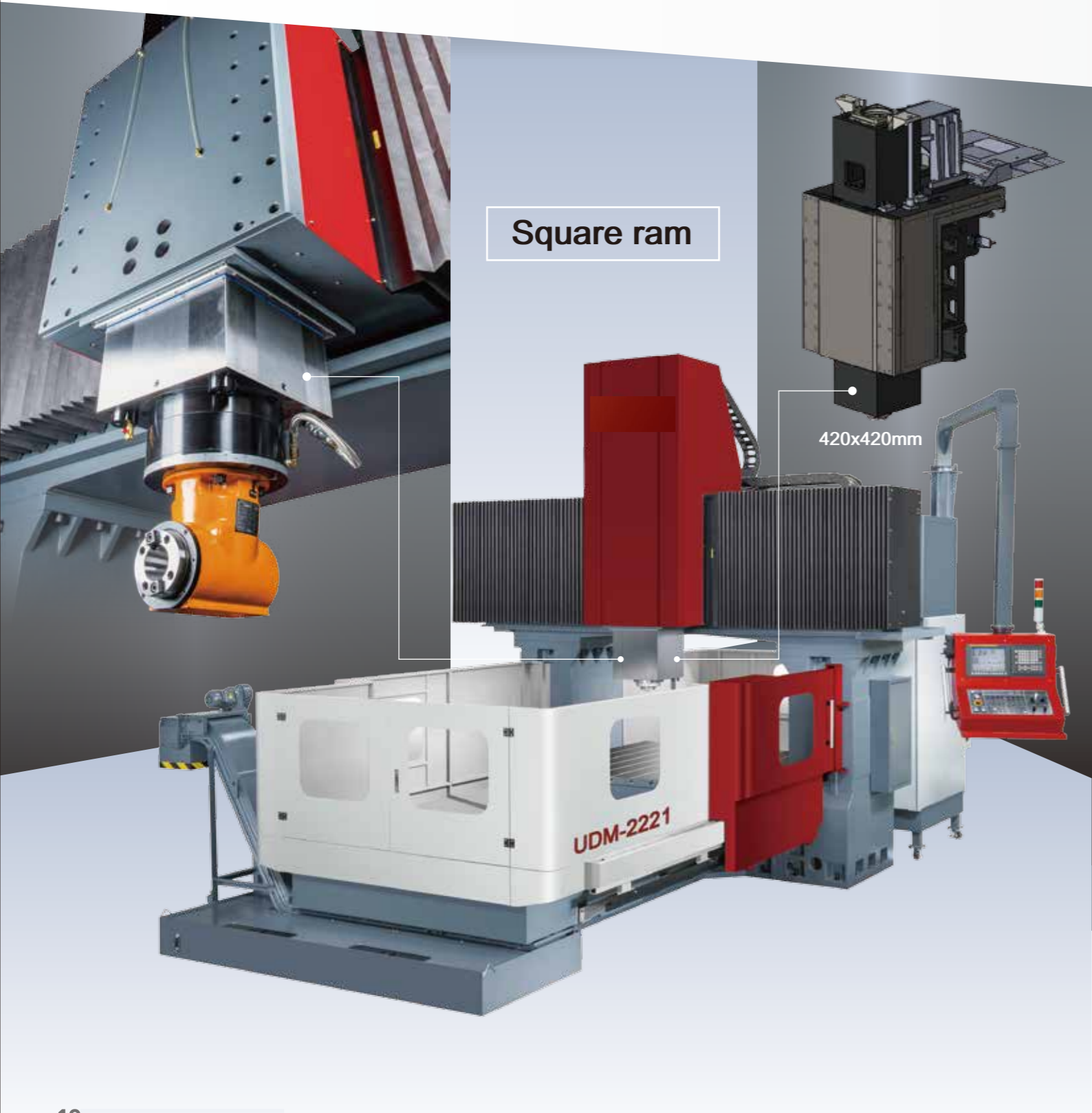

Square ram

420x420mm



Disk Type Magazine
• Load capacity is 24 tools.



Side-mount Chain Type Magazine
• A choice of 32, 40 or 60 tools is available.

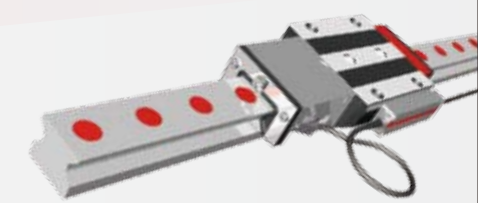

Schneberger Linear Scales
For models with table length 5,000mm and over, X-axis is available to equip with a Schneberger linear scale.



HEIDENHAIN Linear Scales
Linear scales for high positioning accuracy are available for the X, Y and Z-axis.

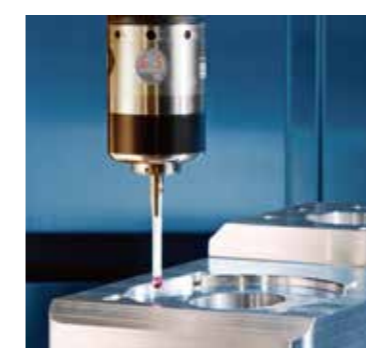

Work Piece Coordinate Measuring



Auto. Tool Length & Diameter Measurement



Thermal growth compensation device for spindle

Various kinds of controllers to choose from.



- STANDARD:**
FANUC 0iMF
- OPTIONAL:**
FANUC 32i-MB/31i-MB
SIEMENS
HEIDENHAIN
MITSUBISHI



Fully automatic change universal milling head Fully automatic change 90° side milling head Fixed type fully automatic universal milling head Semi-automatic milling head
Manual right angle milling head Manual 45° universal milling head Manual 90° universal milling head

Machine Dimensions

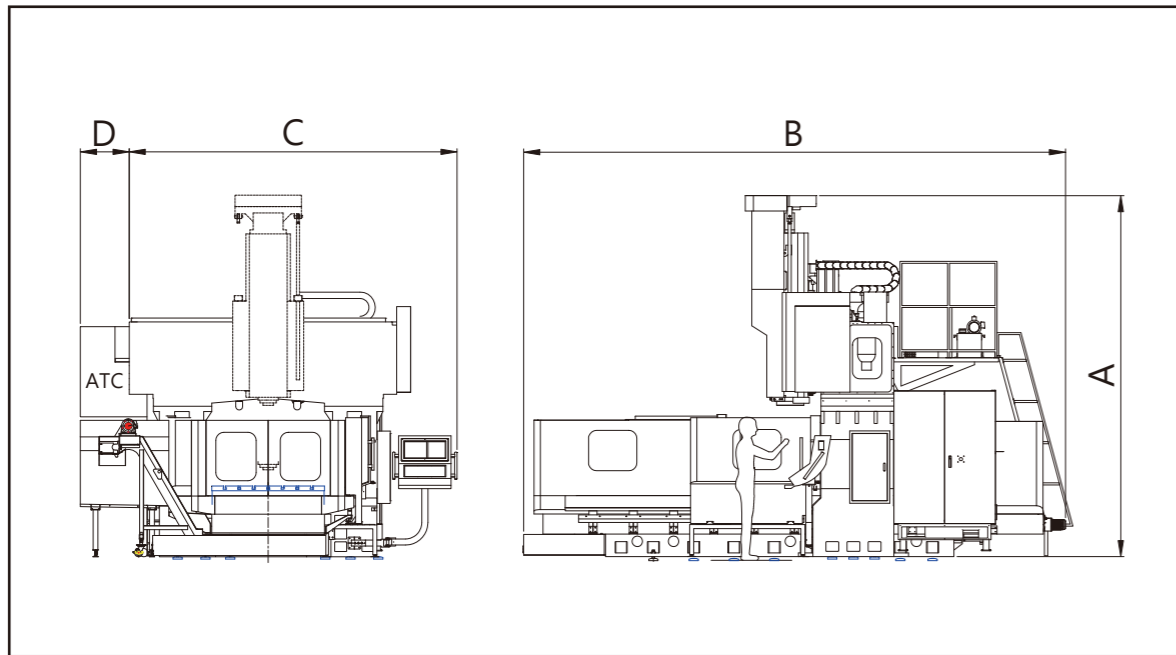

	MODEL	A	B	C	D
Small Model	UDM-2212	3710	5850	3110	760 ~ 1050
	UDM-2215		5850	3310	
	UDM-3212		7850	3110	
	UDM-3215		7850	3310	
	UDM-2217E		5510	4420	
E Type	UDM-2717E	4100	6510	4420	760 ~ 1050
	UDM-3217E		7510	4420	
	UDM-2223E		5510	4880	
	UDM-2723E		6510	4880	
	UDM-3223E		7510	4880	
	UDM-4223E		9710	4880	
	UDM-3228E		7510	5280	
	UDM-4228E		9710	5280	
	UDM-5223E		11710	4880	
	UDM-6223E		13910	4880	
	UDM-5228E		11710	5280	
	UDM-6228E		13910	5280	

■ Specifications are subject to change without prior notice.

	MODEL	A	B	C	D
2 linear guide ways(X-axis)	UDM-2216	Z-800, 3900 Z-1000, 4300 Z-1200, 4700	6280	4150	760 ~ 1050
	UDM-2616		7080	4150	
	UDM-3216		8280	4150	
	UDM-4216		10280	5270	
	UDM-2221		6280	4650	
	UDM-2621				
	UDM-3221		8280	4650	
	UDM-4221		10280	5730	
	UDM-5221		13200	6550	
	UDM-3226		8280	4150	
	UDM-3228		8280	4650	
	UDM-4226		10280	4150	
	UDM-4228		10280	4650	
	UDM-5226		13200	4650	
	UDM-5228		13200	5270	
	UDM-6221		15100	4650	
UDM-6226	15100	5270			
UDM-6228	15100	5730			
3 linear guide ways(X-axis)	UDM-4228B	Z-800, 3900 Z-1000, 4300 Z-1200, 4700	10280	5730	760 ~ 1050
	UDM-5228B		13200	5730	
	UDM-6228B		15100	5730	
	UDM-4232		10280	5730	
	UDM-5232		13200	6130	
	UDM-6232		15100	6130	
	UDM-7232		16100	6130	
	UDM-4236		13200	6130	
	UDM-5236		13200	6550	
	UDM-6236		15100	6550	
	UDM-7236		16100	6550	
	UDM-7232B		17100	6130	
	UDM-7236B		17100	6550	
	UDM-8232B		19100	6130	
	UDM-8236B		19100	6550	

■ Specifications are subject to change without prior notice.