

# POWERFUL FLAT BED CNC LATHES

## 強力平床式CNC車床

560  
510Y x1100/1600/2100/2600/3100

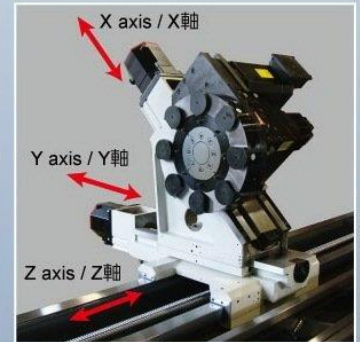

ITEM 項目	MODEL 型號	UNIT 單位	560	510Y
Swing Over Bed	床面旋徑	mm	Ø710	
Swing Over Carriage	鞍架旋徑(最大加工)	mm	Ø560	Ø510
Dist. Between Centers	兩心間距離	mm	1100 / 1600 / 2100 / 2600 / 3100	
Max. Turning Length	最大加工長度	mm	1000 / 1500 / 2000 / 2500 / 3000	
Spindle Bore	主軸孔徑	mm	Ø83 / Ø105 / Ø130 / Ø160	
Spindle Speed(3-step)	主軸轉速(三段)	rpm	40-2000 / 40-1500 / 30-1000	
Main Spindle Motor	主軸馬達	kw	15 / 18.5 / 22 / 26 (Opt.)	
X, Z axis Servo Motor	X/ Z軸伺服馬達	kw	X:3 / Z:4	
Y Axis Servo Motor	Y軸伺服馬達	kw	— / 3	
Hyd. Turret	油壓刀塔	-	V8 / V12 (Opt.) / —	
Live Turret	動力刀塔	-	V8 (VDI 40) (Opt.) / V8 (VDI 40)	
Tailstock Quill Dia.	尾座心軸直徑	mm	Ø105	
Tailstock Quill I.D. Taper	心軸內孔錐度	-	MT#5	

\*All specification and designs are subjected to change without notice. \*本公司保有變更設計之權利，如有更改或改進規格時不另行通知，但不影響前所售之機械品質。