

VH

Series

1600

2000

Manufacturer

Litz Hitech Corp.

No. 18, Yu 9 Road, Yu-Shih Industrial Park,
Tachia District, Taichung City, Taiwan
TEL: +886-4-26815711
FAX: +886-4-26815108
E-mail: sales@litzhitech.com
http://www.litzhitech.com



Litz Machine Tools (JiaXing) Corp.

No. 1398 Hefeng Road, Jiaxing, Zhejiang
TEL: +86-573-82222735
FAX: +86-573-82222739
E-mail: sales.jl@litzhitech.com
http://www.litzchina.cn



Welcome to Litz website for more information

Dealer



CNC
MACHINERY SALES AUSTRALIA



Vertical machining center

High Performance Machining Center

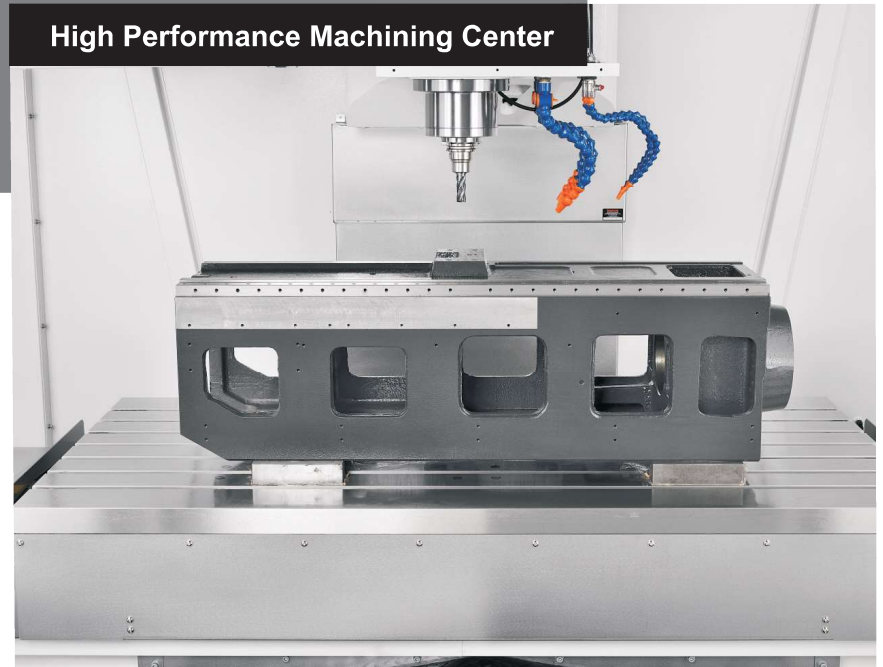

Litz Hitech Corp. | Litz Machine Tools (JiaXing) Corp.

design for increasing your productivity

- The major construction parts are based on Meehanite cast iron, which is stable in structure and long-term quality is assured.
- Casting parts are calculated and analyzed by the finite element method. Proper structure strength combined with enhanced ribs provides high rigidity for the machine.
- A linear guideway is applied on the 3-axes, supporting heavy loads, rapid moving, and assuring precise positioning.

High rigidity, high-precision structure design

- A wide base, box-shaped column, enhanced saddle, full span supports for heavy loads, and robust structure all contribute to its ability for heavy duty machining.
- Enhanced ribs inside the spindle head and a proper contact length ratio between the spindle head and column provide solid support for the spindle.

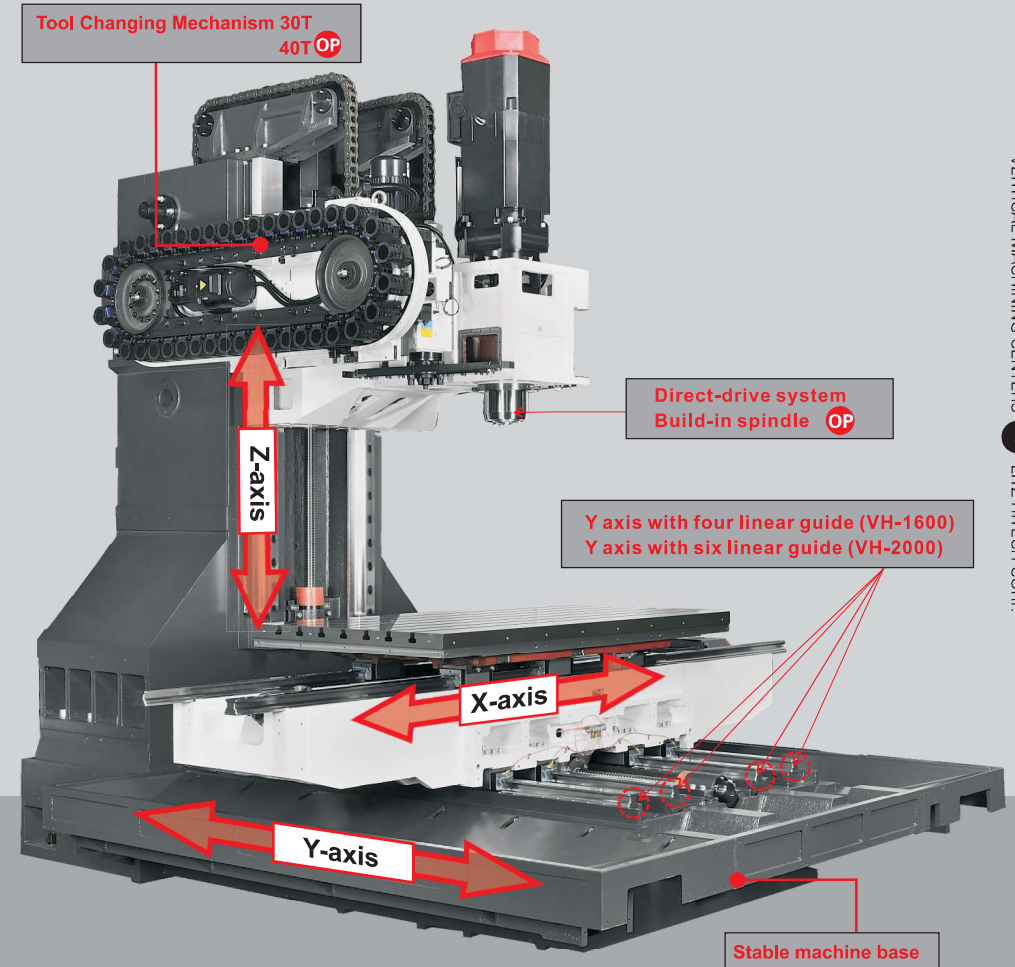

VH-1600A/B

Linear Guideway with High Speed and High Precision

Linear guide way



- A linear guideway with zero backlash ensures a consistent cutting surface on curved or tilted surfaces.
- Suitable for high speed operation and the horsepower requirement is minimized.
- By using rolling contact instead of sliding contact, the linear guide reduces the friction loss and increases the sensitivity and positioning precision.

Y axis with two linear guide ways and four linear guide way blocks

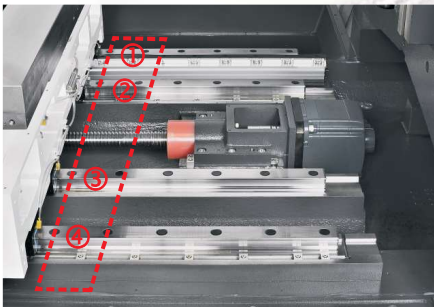

- The machine is equipped with a collision protection device which can absorb collisions due to machine malfunctions or mistakes made by operators. The damage caused by the collision can be minimized and still maintain the design precision.

Extended Z axis linear way blocks

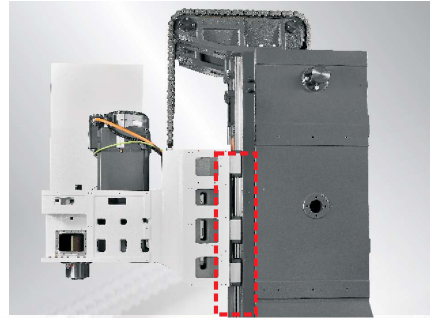

- Extended linear guide way blocks provide the better stability and rigidity.

X axis with two linear guide ways and six linear guide way blocks

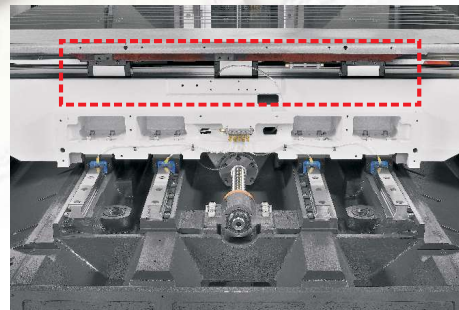

- The X/Y/Z-axis can be equipped with a linear scale system to detect thermal displacement due to rapid movement of the machine. The thermal displacement result will be sent to the controller for compensation, suitable for high precision parts machining.
- The linear scale system is designed with a gas protection device to prevent the linear scale from contamination by dust and oil vapor. The precision of the linear scale is assured and the service time can be extended.

Oil/Coolant Separating Design

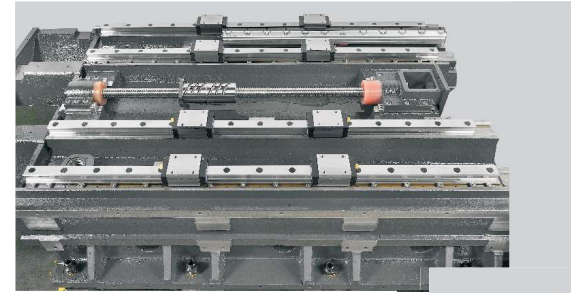

- The oil/coolant separating design can separate lubricating oil and coolant effectively. Coolant quality will not be reduced due to mixing and the machining quality can be assured.

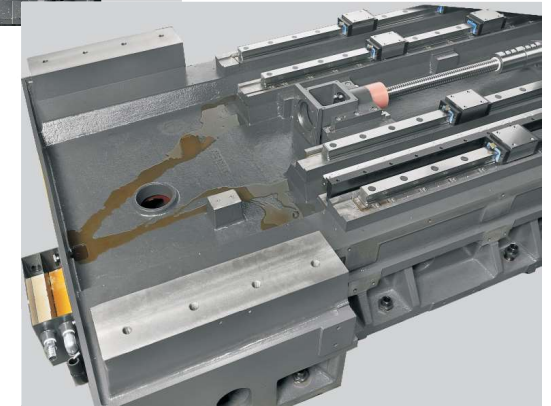

3-axis coolant through OP

The ballscrew transmission system employs hollow cooling design to minimize heat and thermal expansion of ball screw in high-speed operations with coolant oil to balance high speed and high precision at the same time.

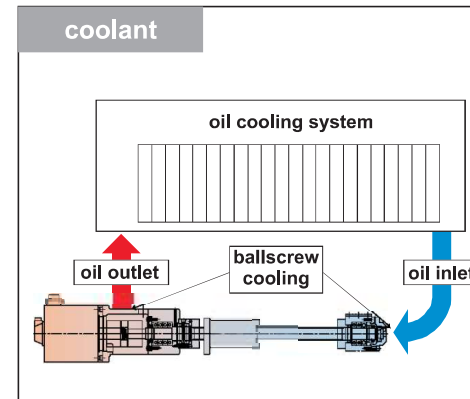

Effectiveness Graph

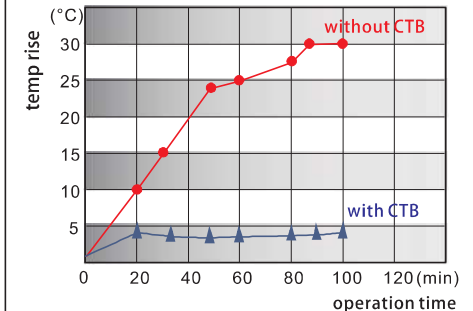

Spindle Transmission

Direct-drive system

Machine Specifications

Spindle Speed: 12000rpm
15000rpm **OP**

Spindle Power: 11/15kw
15/18.5kw

Spindle Torque: 70/95.5 N-m
102/126 N-m

Tool specification: BBT-40

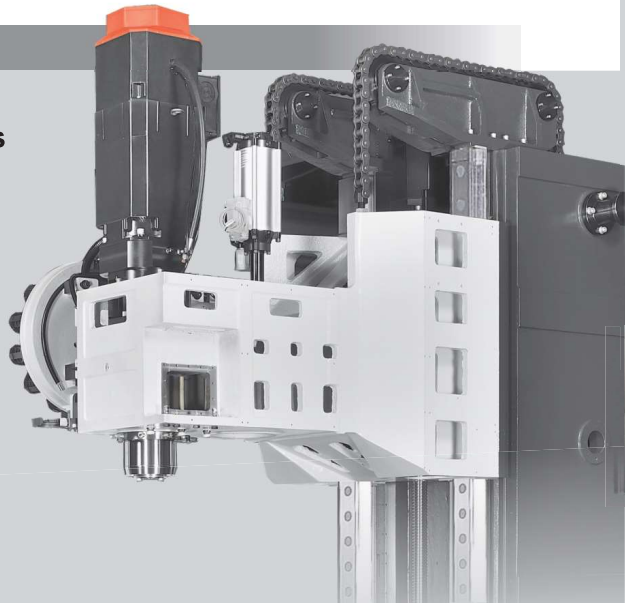

Build-in spindle **OP**

Machine Specifications

Spindle Speed: 15000rpm
20000rpm **OP**

Spindle Power: 11/15kw
15/18.5kw

Spindle Torque: 69.9/95.5 N-m
63.7/78.3 N-m

Tool specification: HSK-63A



Arm-type Tool Changing Mechanism

- A fast, simple, reliable, and durable tool exchange device, providing stable and reliable exchange of tools.
- A unique tool exchange device design, an advanced cam-drive mechanism capable of random tool selection can be achieved using the PLC software control.

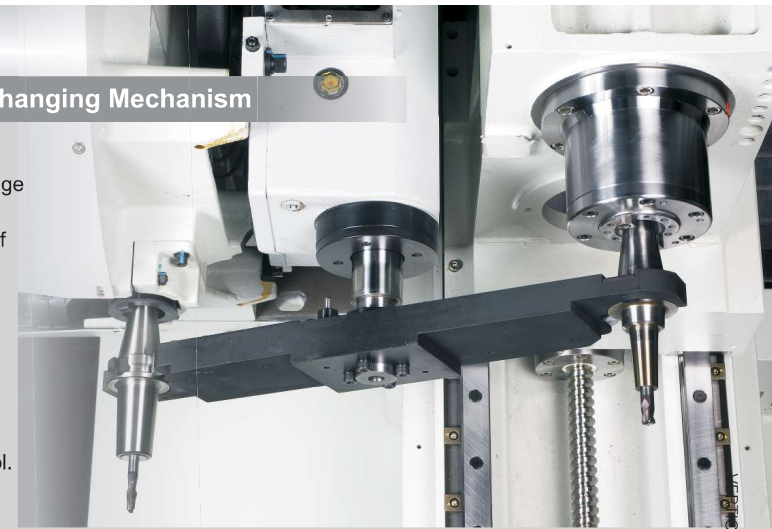

24 tools(B)/30T(A)

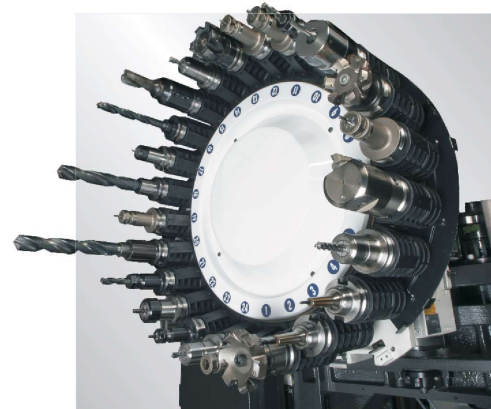

32tools(B)/40T(A) **OP**

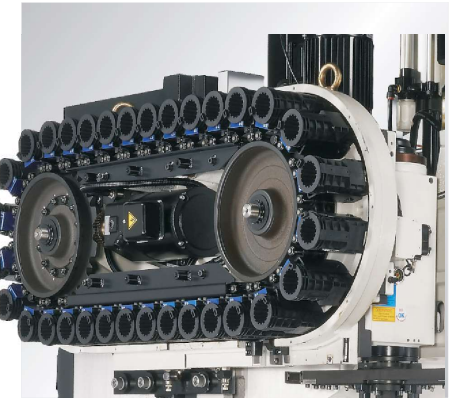

Mode	Number of Tools	Tool specification	Max. tool length (mm)	Max. tool dia. (mm)
VH-1600A	30T	BBT-40	300	85/150
VH-1600B	24T	BBT-50	350	125/250
VH-2000A	30T	BBT-40	300	85/150
VH-2000B	24T	BBT-50	350	125/250

Standard Function - Optional Function

Machine



1 Lighting System

High brightness work light is standard for easy loading and unloading work from the table.

2 Portable MPG



Portable hand wheel beneficial to operation flexibility.

3 Full enclosed ATC

Full enclosed ATC design to prevent duct or oil mist go inside the ATC area.

4 Tool Length Measurement OP



The automatic tool measuring system will measure the tool length and input the result into the controller automatically for compensation.

5 Workpiece Measurement System OP



Select Renishaw Workpiece Measurement System for use

- MP10 is used for workpiece coordinate setting and processing machine workpiece inspection.
- 0MM module is able to send CNC message and receive from M12 interface

System characteristics

- Signal transmission range: MP10 is used for 3degree or70 degree, minimum at 130 degree
- 360-degree inspection is limited to a maximum length of6m.
- Battery lifetime allows continuous use for 140 hours.
- Repeatability 1µm, Measurement speed: 480 mm/min.
- Measurement can use M code or automatic measurement
- Waterproof at IP68 level.
- Equipped with over-stroke probe damage protection.

6 Auto power ON for machine warm-up Auto power Off

Operator can set power On timing and activate the warm-up program by timer, as well as power Off.

7 3 color signal light



8 Safety switch (standard)



The machining program starts only when the safety door is closed to ensure operator safety.

9 DDR Motor OP



The embedded rotating 4th axis has the features of high rotating speed, high precision, high maximum torque, high braking torque and zero backlash, suitable for precision parts machining with high performance.

Coolant

10 Programmable nozzle adjustment device OP



Programmable nozzle adjusting device: you may add M code in machining scripts to change nozzle angle according to tool length during machining.

11 Coolant through spindle device and filter OP

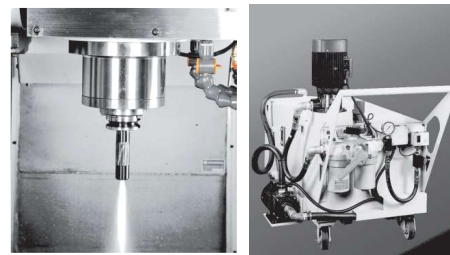

With the addition of the coolant through spindle system, the cutting coolant passes through the center of the spindle and is ejected at the tip of cutter to directly cool the workpiece and the cutting blade of the cutter by removing the heat generated from cutting in order to ensure excellent cutting quality, and it is suitable for component parts of deep hole processing.

12 High Precision Linear Scale OP

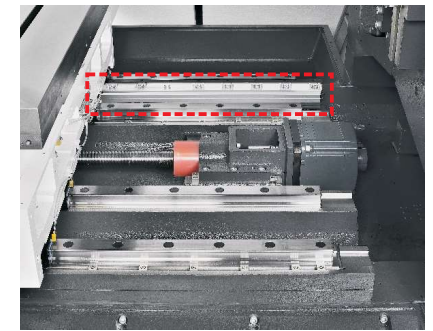

The X/Y/Z-axis can be equipped with a linear scale system to detect thermal displacement due to rapid movement of the machine. The thermal displacement result will be sent to the controller for compensation, suitable for high precision parts machining.

Chip Management

13 chain tynechip conveyor OP

Suitable for chip length from 30-150mm

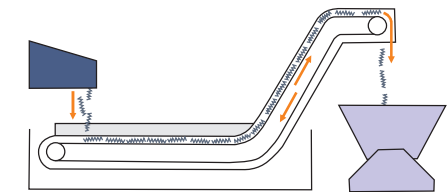

14 scraper tynechip conveyor OP

scraper tynechip conveyor can remove the long and curl chips through outer channel; and remove the coolant and small chips through inner channel.

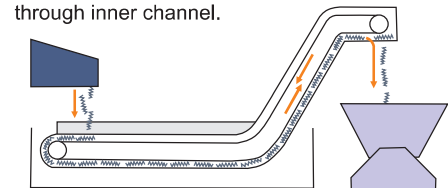

Standard Function - Optional Function

Front and top door in one piece.

Wide opened front for easier loading/unloading.



Operator close to table and spindle.

Operator can easily approach workpiece.

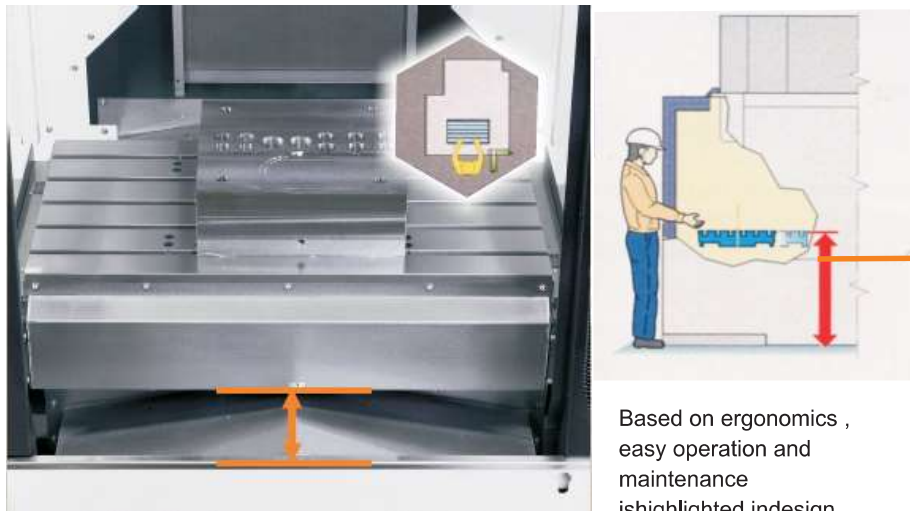

Based on ergonomics, easy operation and maintenance is highlighted in design.

Tool clamp/unclamp button

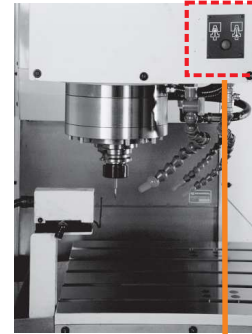

Operator can easily clamp or unclamp the tool from the front.

Rotatable operation panel



Ergonomic operation panel design.

Full ATC guard

Full ATC guarding can prevent dust or chip go inside the ATC.

Removable side doors.

Removable side doors help easier maintenance and clean.



Machine Layout

VH-1600A/B

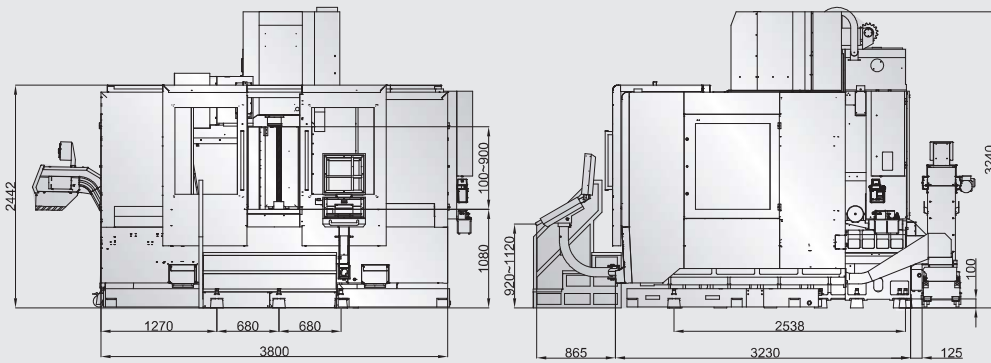

VH-2000A/B

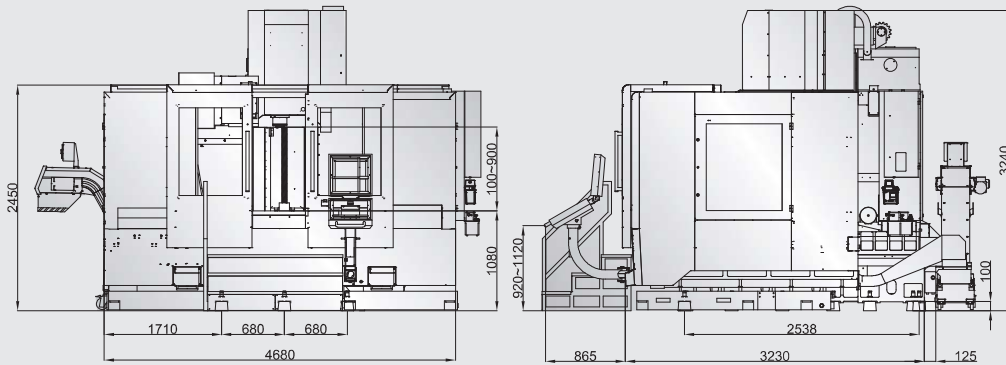

Worktable Dimensions

VH-1600A/B

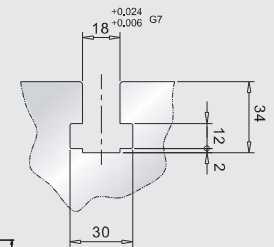
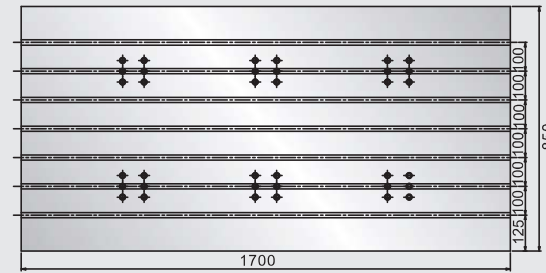

VH-2000A/B

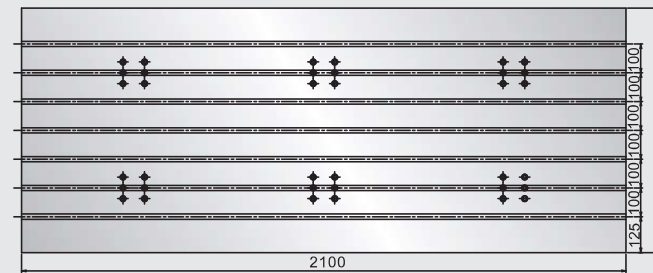

BBT-40

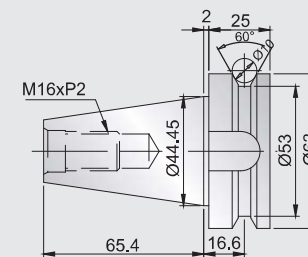
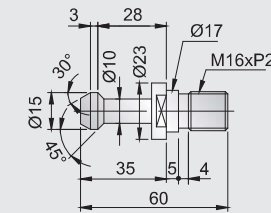

BBT-50

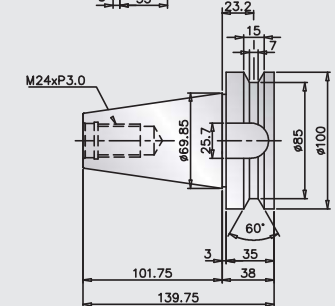
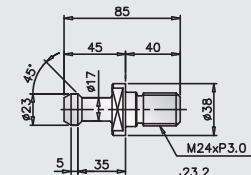

Machine Specifications

Model		VH-1600A(B)	VH-2000A(B)
Travels for 3-axes			
X-axis Travel	mm	1600	2000
Y-axis Travel	mm	900	900
Z-axis Travel	mm	800	800
Spindle nose to worktable surface	mm	100~900	100~900
Spindle			
Spindle Speed	rpm	12000(8000)	12000(8000)
Automatic Tool Changing System			
Number of Tools	pcs	30(24)	30(24)
Max. tool diameter	mm	80/150(125/250)	80/150(125/250)
Max. tool length	mm	300(350)	300(350)
Max. tool weight	kg	7(15)	7(15)
Tool changing method		ARM	ARM
Tool specification		BBT-40 (BBT-50)	BBT-40 (BBT-50)
Motor			
Spindle motor <small>(continuous/30min. rated)</small>	kw(HP)	15/18.5	15/18.5
Motors on X/Y/Z-axis	kw	4 / 4 / 4	4 / 4 / 4
Worktable			
Worktable area	mm	1700x850	2100x850
Worktable max. load capacity	kg	1500	2500
T-slot <small>(No. x Width x Distance from the center)</small>	mm	7x18x100	7x18x100
Rapid Speed			
X-axis rapid speed	M/min	36	20
Y-axis rapid speed	M/min	36	20
Z-axis rapid speed	M/min	24	20
Cutting feed rate	mm/min	1-8000	1-20000
Controller			
FANUC		0i-MF PLUS 3	0i-MF PLUS 3
Miscellaneous			
Machine Weight	kg	19000	21000
Power Consumption	KVA	42	42
Coolant Tank Capacity	L	500	550
Compressed air source	kg/cm2	6	6

- All the photos contained herein are for reference only. In case of any discrepancy with the actual machine parts, the actual machine shall prevail.
- LITZ reserves the right to modify the product specifications, appearance, equipment or discontinue the products.

Equipment List

	VH-1600A	VH-1600B	VH-2000A	VH-2000B
Spindle				
Spindle speed: 8000 RPM (Direct-drive)	—	●	—	●
Spindle speed: 1000 RPM (Direct-drive)	—	○	—	○
Spindle speed: 12000 RPM (Direct-drive)	●	—	●	—
Spindle speed: 15000 RPM (Direct-drive)	○	—	○	—
Spindle speed: 15000 RPM (Build-in)	○	—	○	—
Spindle speed: 20000 RPM (Build-in)	○	—	○	—
Spindle water chiller(a must for build-in spindle)	○	○	○	○
Spindle dust-proof air-sealing system	●	●	●	●
Cooling System				
Spindle external programmable air blow system	●	●	●	●
Stop block for oil feed tool holder	○	○	○	○
Splash ring(arm type only)	○	○	○	○
Coolant cooling system	○	○	○	○
Chip Removal System				
Chip auger inside the machine	●	●	●	●
Chip conveyer	○	○	○	○
Chip cart	●	●	●	●
Coolant gun for machine cleaning	●	●	●	●
Air gun for machine cleaning	●	●	●	●
Wash down device	○	○	○	○
Fully-covered sheet metal	●	●	●	●
Measurement System				
Tool length measurement system	○	○	○	○
Workpiece measurement system	○	○	○	○
Production and Workshop				
Production management and network service	☆	☆	☆	☆
Human-Machine Interface -intelligent machine	☆	☆	☆	☆
Oil Mist Collector	○	○	○	○
Oil/coolant separator				
Disc type oil/coolant separator	○	○	○	○
Machine oil/coolant separation system	●	●	●	●
ATC System				
Automatic Tool Changer Mechanism (ATC)	●	●	●	●
BBT-40 tool specification	●	—	●	—
BBT-50tool specification	—	●	—	●
Arm type tool magazine 24T	—	●	—	●
Arm type tool magazine 30T	●	—	●	—
Arm type tool magazine 32T	—	○	—	○
Arm type tool magazine 40T	○	—	○	—
3-Axes Transmission System				
3-axes coolant thru ballscrew(CTB)	○	○	○	○
3-axes linear roller guideway	○	○	○	○
3-axes linear scale	○	○	○	○
Z-axis brake motor system	●	●	●	●
Controller				
FANUC	●	●	●	●
Mitsubishi M80	○	○	○	○
Siemens 828D	☆	☆	☆	☆
Electrical Parts				
Work light	●	●	●	●
Alarm indicator	●	●	●	●
M30 automatic power off system	●	●	●	●
Heater exchanger for electrical cabinet	●	●	●	●
Air-conditioner for electrical cabinet	○	○	○	○
Miscellaneous				
4th Axis (rotating table)	○	○	○	○

● Standard ○ Options ☆ Upon request