

- CNC VERTICAL LATHES
- TWIN STAR VERTICAL CNC LATHES
- CNC ULTRA PERFORMANCE VERTICAL TURNING CENTERS WITH C AXIS
- HEAVY DUTY VERTICAL LATHES
- CNC ULTRA PERFORMANCE HEAVY DUTY VERTICAL TURNING CENTERS WITH C AXIS
- TWIN TURRET CNC VERTICAL TURNING CENTERS
- DOUBLE COLUMN 5 AXIS MACHINING CENTERS
- SPECIAL PURPOSE MACHINES

Heavy Duty Vertical Lathes

THE POWER TO SPIN THE WORLD



CE ISO 9001

YU SHINE PRECISION MACHINE CO., LTD.

No. 538, Sioucai Rd., Yangmei Township, Taoyuan County 326, Taiwan

Tel: 886-3-288-8899

<http://www.ysp.tw>

Fax: 886-3-288-8866

E-mail: ysp@ysp.tw



YSP

Yu Shine Exhibition Hall

*Heavy Duty
Vertical Lathes*

Quality, Innovation, Service, and Sustainability!



VL-1000ATC



VL-1200ATC



VL-1600ATC



VL-2000ATC



VL-2500ATC



VL-3000ATC

Wonderwork with Best Accuracy

Yu Shine was established in 1983 to design special application machine tools. Consistent technological progress and strict quality control has led our complete line of machine tools to be CE and ISO-9001 certified. We are known for precision, accuracy, and performance. Yu Shine machine tools are widely trusted by customers in Japan, Germany, USA, South America, Southeast Asia, and Europe – 38 countries in all! We offer a huge range of machine tools including our Heavy Duty Vertical Lathes, adapted to many different industries and applications around the world.

In 2007 we worked with world famous machine tool builders in Germany and Japan. Teamwork and technical exchange led to many advances in machine tool performance. Yu Shine also invested US\$6.8 million constructing a new 8800m² factory. Completed in 2007, this facility now employs 100 people. Integrating resources like this has helped Yu Shine achieve our full sales potential.



Yu Shine Vertical Lathes combine outstanding productivity and service to provide customers with a significant market advantage. We believe in achieving excellence and are always finding ways to improve. If you are looking for precision, innovation, excellent service, and a practical, sustainable approach to business, Yu Shine Heavy Duty Vertical Lathes are consistently ahead of the competition.



R&D and QC

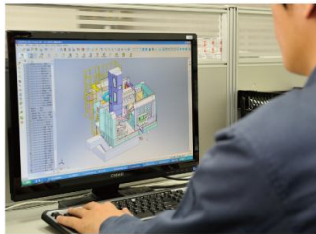

R&D Strategy

Our R&D team maintains an outstanding design philosophy and solid track record of innovation. Devoted to forward thinking product development, progressive and innovative technology is fundamental to our corporate development. Yu Shine anticipates emerging demands from an ever evolving market and delivers timely solutions year after year.



QC Testing

Yu Shine is well known for extremely diligent quality control. From initial prototype development, to final product delivery, strict testing at each stage is required before moving to the next. Careful attention to detail means defect free machines.



Renishaw XL-80 Laser Measurement System

Accurately tests linear, angular, straightness, squareness and flatness measurements, as well as calibrates rotary axes to within ± 1 arc second accuracy.

Standard Accessories

HEAVY DUTY VERTICAL LATHES



▲ Air Conditioner for Spindle Gearbox



▲ Hydraulic Unit



▲ Dual Speed Gearbox



▲ Auto Lubrication System

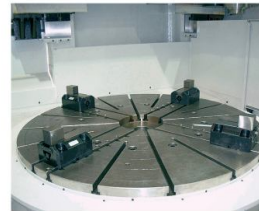

▲ 4 Jaw Manual Rotary Table

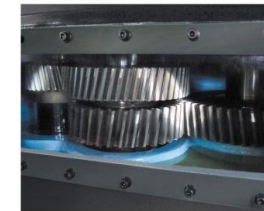

▲ Rotary Table Transmission



▲ Fanuc Control System



▲ Crossrail Clamping System



▲ ATC Magazine



▲ Automatic Balancing System



▲ Crossrail Hoist Motor

VL-1000ATC+C
 VL-1200ATC+C
 VL-1600ATC+C
 VL-2000ATC+C
 VL-2500ATC+C
 VL-3000ATC+C



C Axis

Power spindle combines the spindle motor and a 2 step transmission to provide powerful face milling, end milling, drilling, tapping and grinding.

C-Axis Performance Chart

VL-1000 / 1200 / 1600 series
 Fanuc-α8 (7.5/11 kw)

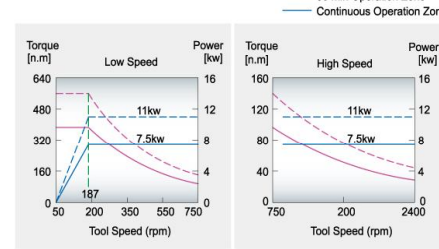

VL-2000 / 2500 / 3000 series
 Fanuc-α12 (11/15 kw)

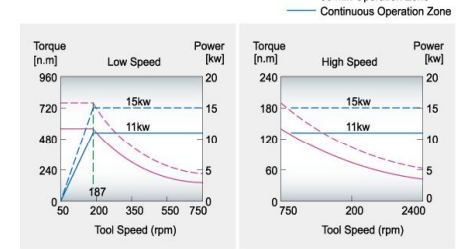

VL-2000 / 2500 / 3000 series
 Fanuc-α15 (15/15.8 kw) – Optional

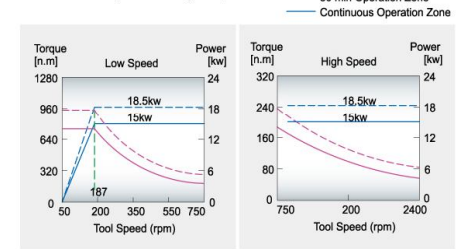

CF Axis

High resolution servo motor with precision worm and worm gear assure high precision indexing up to 6 arc seconds. A second power spindle for multi-side machining and complex parts machining (e.g. cam) is also available. Turning, milling, drilling and tapping are accomplished in a single set up. This greatly reduces workpiece set-up time and saves machine related costs.

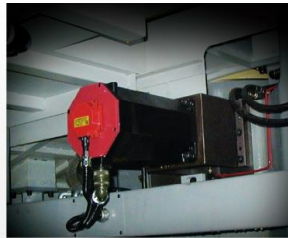

Multi-function Machining

Equipped with a second power spindle, the C and CF axes provide turning, face milling, side milling, drilling, grinding and tapping operations all in a single set-up.

Face Milling



Boring

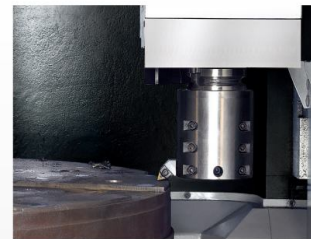

Tapping

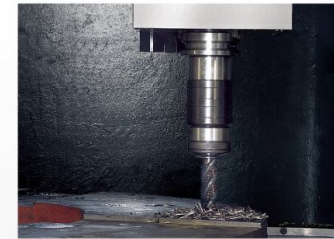

Grinding (Optional)



Drilling



Side Milling

Optional Accessories

+APC Improve vertical workpiece clamping times and overall efficiency by adding an automatic pallet changer to your heavy duty vertical lathe. Yu Shine has the years of research and development of automation equipment needed to satisfy all your production needs.



Optional Accessories



▲ ATC 30T / 60T / 90T



▲ Active Workpiece Checking



▲ Active Tool Checking



▲ Tool Holder

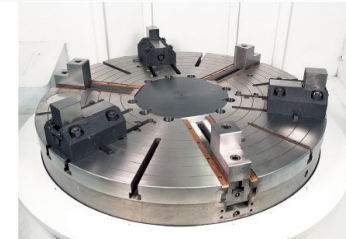

▲ 3 or 4 Jaw Power Chuck & Hand Chuck

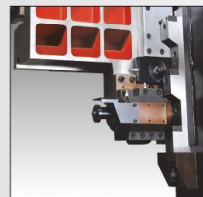

▲ Crossrail Navigation System



▲ Paper Filter



▲ Hirth Coupling Tool System



▲ Linear Encoder



▲ Air Conditioner for Electrical Cabinet



▲ Siemens Control

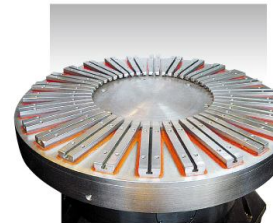

▲ Magnetic Chuck



▲ 3 / 6 Jaw Power Chuck



HEAVY DUTY VERTICAL LATHES

Output Performance Chart

VL-1000 VL-1200 VL-1600 VL-2000 VL-2500 VL-3000

VL-1000

Table dia.	ø1000 mm
Max. swing dia.	ø1350 mm
Max. turning dia.	ø1150 mm
Max. turning height	1070 mm
Table speed	2~600 rev/min
Max. load on table	4000 kg

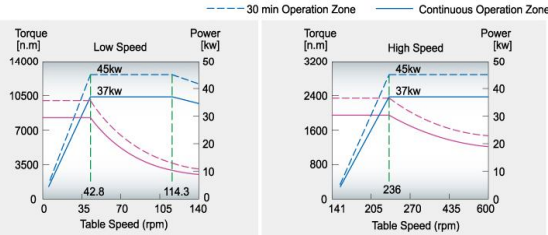

- Fanuc – α 40 / 6000i + gear box (1/5.5)
- 37 / 45 kw (50 / 60 hp)
- 2~140 rpm/min (low speed)
- Fanuc – α 40 / 6000i + gear box (1/1)
- 37 / 45 kw (50 / 60 hp)
- 141~600 rpm/min (high speed)

VL-2000

Table dia.	ø2000 mm
Max. swing dia.	ø2500 mm
Max. turning dia.	ø2300 mm
Max. turning height	1700 mm
Table speed	2~200 rev/min
Max. load on table	10000 kg

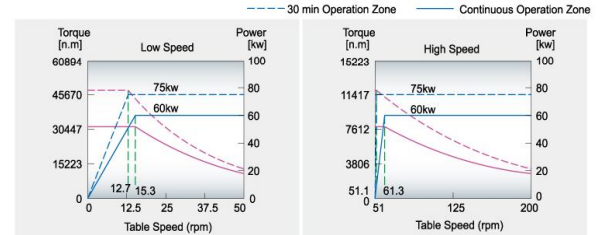

- Fanuc – α 60 / 4500HVi + gear box (1/4)
- 60 / 75 kw (80 / 100 hp)
- 2~50 rpm/min (low speed)
- Fanuc – α 60 / 4500HVi + gear box (1/1)
- 60 / 75 kw (80 / 100 hp)
- 51~200 rpm/min (high speed)

VL-1200

Table dia.	ø1250 mm
Max. swing dia.	ø1600 mm
Max. turning dia.	ø1350 mm
Max. turning height	1350 mm
Table speed	2~300 rev/min
Max. load on table	5000 kg

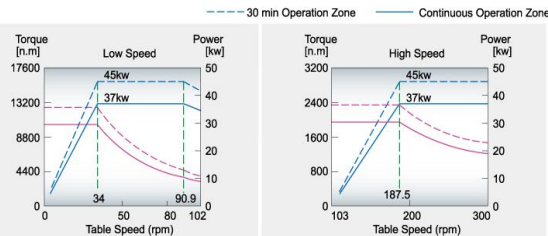

- Fanuc – α 40 / 6000i + gear box (1/5.5)
- 37 / 45 kw (50 / 60 hp)
- 2~102 rpm/min (low speed)
- Fanuc – α 40 / 6000i + gear box (1/1)
- 37 / 45 kw (50 / 60 hp)
- 103~300 rpm/min (high speed)

VL-2500

Table dia.	ø2500 mm
Max. swing dia.	ø3000 mm
Max. turning dia.	ø2800 mm
Max. turning height	1700mm
Table speed	2~160 rev/min
Max. load on table	15000 kg

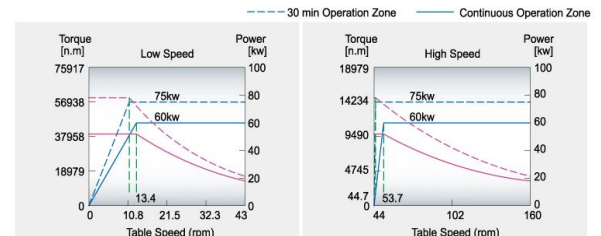

- Fanuc – α 60 / 4500HVi + gear box (1/4)
- 60 / 75 kw (80 / 100 hp)
- 2~43 rpm/min (low speed)
- Fanuc – α 60 / 4500HVi + gear box (1/1)
- 60 / 75 kw (80 / 100 hp)
- 44~160 rpm/min (high speed)

VL-1600

Table dia.	ø1600 mm
Max. swing dia.	ø2000 mm
Max. turning dia.	ø1800 mm
Max. turning height	1350 mm
Table speed	2~256 rev/min
Max. load on table	8000 kg

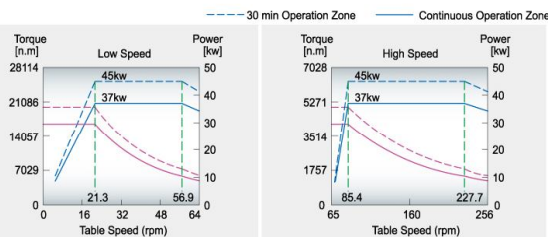

- Fanuc – α 40 / 6000i + gear box (1/4)
- 37 / 45 kw (50 / 60 hp)
- 2~64 rpm/min (low speed)
- Fanuc – α 40 / 6000i + gear box (1/1)
- 37 / 45 kw (50 / 60 hp)
- 65~256 rpm/min (high speed)

VL-3000

Table dia.	ø3000 mm
Max. swing dia.	ø3500 mm
Max. turning dia.	ø3400 mm
Max. turning height	1650mm
Table speed	2~120 rev/min
Max. load on table	20000 kg

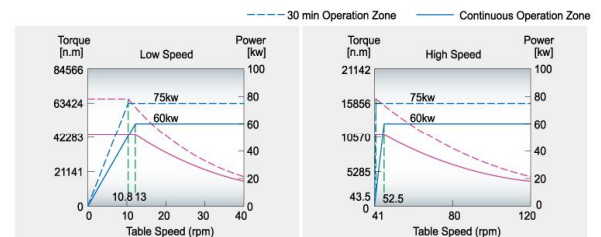

- Fanuc – α 60 / 4500HVi + gear box (1/4)
- 60 / 75 kw (80 / 100 hp)
- 2~40 rpm/min (low speed)
- Fanuc – α 60 / 4500HVi + gear box (1/1)
- 60 / 75 kw (80 / 100 hp)
- 41~120 rpm/min (high speed)

Tool System

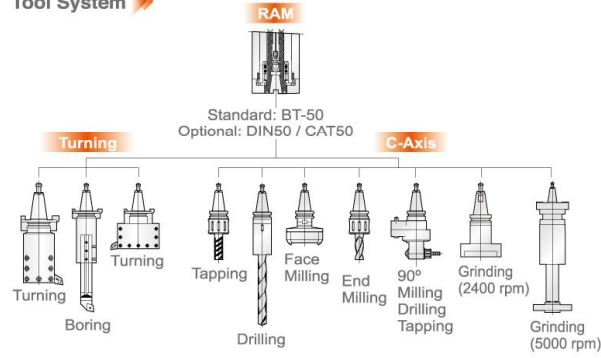

Tool Holder

	L	Tool Type
A-32-160	160	□ 32 x 32
A-32-200	200	□ 32 x 32
A-32-250	250	□ 32 x 32
A-1 1/4"-160	160	□ 1 1/4" x 1 1/4"
A-1 1/4"-200	200	□ 1 1/4" x 1 1/4"
A-1 1/4"-250	250	□ 1 1/4" x 1 1/4"

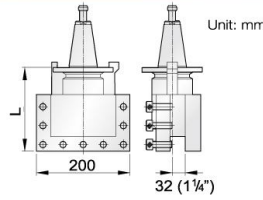

	L	D
C-25-150	150	ø25
C-32-180	180	ø32
C-40-200	200	ø40
C-50-250	250	ø50
C-63-280	280	ø63

	L	D
C-1"-150	150	ø1"
C-1 1/4"-180	180	ø1 1/4"
C-1 1/2"-200	200	ø1 1/2"
C-2"-250	200	ø2"
C-2 1/2"-280	280	ø2 1/2"

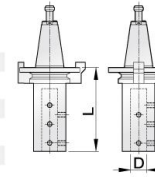

	L	D	Tool Type
B-25-200	200	ø110	□ 25 x 25
B-25-250	250	ø110	□ 25 x 25
B-25-350	350	ø110	□ 25 x 25
B1-25-200	200	ø130	□ 25 x 25
B1-25-250	250	ø130	□ 25 x 25
B1-25-350	350	ø130	□ 25 x 25
B-1"-200	200	ø110	□ 1" x 1"
B-1"-250	250	ø110	□ 1" x 1"
B-1"-350	350	ø110	□ 1" x 1"
B1-1"-200	200	ø130	□ 1" x 1"
B1-1"-250	250	ø130	□ 1" x 1"
B1-1"-350	350	ø130	□ 1" x 1"

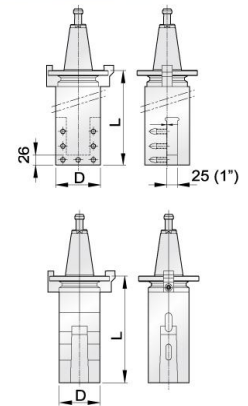

	L	D	Tool Type
D-MT5-230	230	ø85	MT5
D-MT6-300	300	ø100	MT6

Jaws Clamp I.D & O.D

	A	B	C	D
VL-1000	1090	940	370	220
VL-1200	1340	1195	390	240
VL-1600	1660	1515	390	240
VL-2000	2060	1915	390	240
VL-2500	2550	2375	485	310
VL-3000	3030	2860	485	310

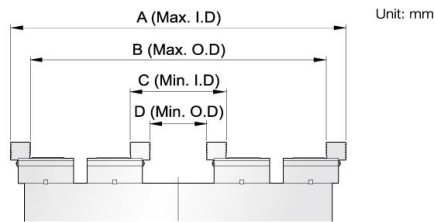

Axis Travel & Tooling Interference

	A	B	C	D	E	F	G
VL-1000	1000	1150	1070	800	775	220	500
VL-1200	1250	1350	1350	900	875	200	800
VL-1600	1600	1800	1350	900	1125	150	800
VL-2000	2000	2300	1700	1000	1375	200	1150
VL-2500	2500	2800	1700	1000	1625	200	1150
VL-3000	3000	3400	1650	1000	1925	200	1200

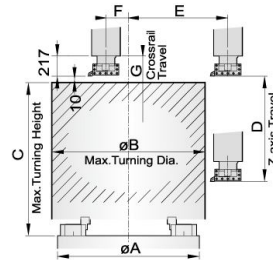

Power Jaws Dimensions

VL-1000 / VL-1200 / VL-1600 / VL-2000

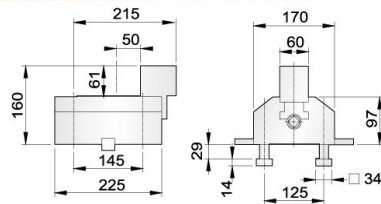

VL-2500 / VL-3000

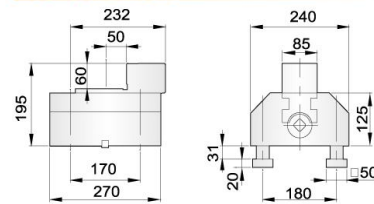

Machine Dimensions

	L1	L2	W1	W2
VL-1000	4600	3690	5500	3950
VL-1200	4700	4100	5870	4000
VL-1600	5050	4400	6300	4450
VL-2000	4950	4320	7320	6450
VL-2500	5400	4770	7570	6700
VL-3000	6100	5470	8700	7870

	H1	H2	H3	H4
VL-1000	5330	3385	2720	1164
VL-1200	5500	3775	2800	1120
VL-1600	5500	3775	2800	1120
VL-2000	6600	4325	3500	1140
VL-2500	6600	4325	3500	1140
VL-3000	6700	4560	3600	1280

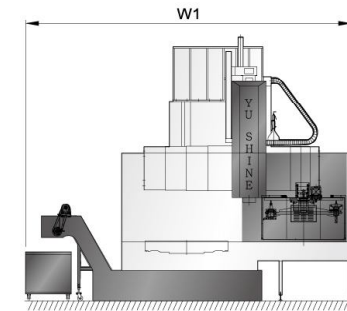
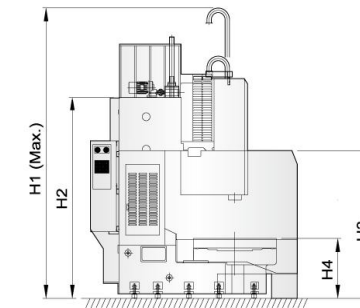
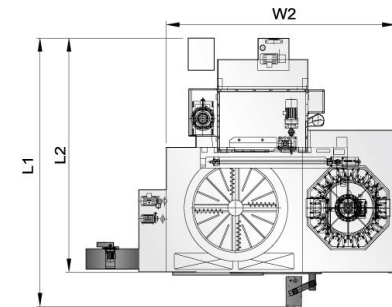



HEAVY DUTY VERTICAL LATHES

Specifications

()=Optional N/A=Not Available * Specifications are subject to change without notice.

Unit	VL-1000ATC	VL-1000ATC+C	VL-1200ATC	VL-1200ATC+C	VL-1600ATC	VL-1600ATC+C
CAPACITY						
Table Diameter	mm	ø1,000	ø1,000	ø1,250	ø1,250	ø1,600
Max. Swing Diameter	mm	ø1,350	ø1,350	ø1,600	ø1,600	ø2,000
Max. Turning Diameter	mm	ø1,150	ø1,150	ø1,350	ø1,350	ø1,800
Max. Turning Height	mm	1,070	1,070	1,350	1,350	1,350
Max. Load on Table	kg	4,000	4,000	5,000	5,000	8,000
#1 SPINDLE						
Spindle Speed – Low	rpm	2~140	2~140	2~102	2~102	2~64
– High		141~600	141~600	103~300	103~300	65~256
Max. Torque	N.m	10,000	10,000	12,500	12,500	20,000
#2 SPINDLE						
Spindle Speed	rpm	N/A	2,400	N/A	2,400	2,400
Max. Torque	N.m	N/A	550	N/A	550	550
TRAVEL / FEEDRATE						
X Axis Travel	mm	1,350	1,350	1,475	1,475	1,675
Z Axis Travel	mm	800	800	900 (1,200)	900 (1,200)	900 (1,200)
Vertical Travel of Crossrail	mm	500	500	800	800	800
X Axis Rapid Feedrate	mm/min	12,000	12,000	12,000	12,000	12,000
Z Axis Rapid Feedrate	mm/min	10,000	10,000	10,000	10,000	10,000
Cutting Feedrate	mm/rev	0.01~50	0.01~50	0.01~50	0.01~50	0.01~50
Manual Feedrate	mm/min	0~1,260	0~1,260	0~1,260	0~1,260	0~1,260
TOOLING						
No. of Tools		12 Tools	16 Tools	12 Tools	16 Tools	12 Tools
Type of Tool Shank		BT50	BT50	BT50	BT50	BT50
Max. Tool Weight	kg	50	50	50	50	50
Max. Loading of ATC	kg	360	450	360	450	360
Tool Change Time (ATC)	sec	30	30	30	30	30
MOTOR						
#1 Spindle Motor (Cont/30min)	kw	37/45	37/45	37/45 (60/75)	37/45 (60/75)	37/45 (60/75)
#2 Spindle Motor (Cont/30min)	kw	N/A	7.5/11 (11/15)	N/A	7.5/11 (11/15)	N/A
X Axis Servo Motor	kw	7.0	7.0	7.0	7.0	7.0
Z Axis Servo Motor	kw	7.0	7.0	7.0	7.0	7.0
CF Axis Servo Motor	kw	N/A	7.0	N/A	7.0	7.0
Crossrail Hoist Motor	kw	1.5	1.5	2.25	2.25	2.25
Hydraulic Motor	kw	3.75	3.75	3.75	3.75	3.75
Conveyor Motor	kw	0.375	0.375	0.375	0.375	0.375
Coolant Pump	kw	0.75+0.75+1.1	0.75+0.75+1.1	1.7+1.1	1.7+1.1	1.7+1.1
CAPACITY						
Hydraulic Tank	Liter	100	100	100	100	100
Coolant Tank	Liter	700	700	700	700	700
MACHINE BODY						
Machine (L1 x W1)	mm	4,600 x 5,500	4,600 x 5,500	4,700 x 5,800	4,700 x 5,800	5,050 x 6,300
Machine (H1)	mm	5,330	5,330	5,500	5,500	5,500
Machine Weight	kg	24,000	25,000	32,000	33,000	35,000
Power Requirement	kva	75	85	80	90	80

Standard Accessories

- 4 Jaw Manual Chuck
- Chip Conveyor, Chip Cart
- Coolant System
- Auto Lubrication System
- Lighting Lamp
- Alarm Lamp
- Operation Manual
- Hydraulic Unit
- Crossrail Hoist Motor
- Clamping System for Crossrail
- ATC Magazine
- Air Conditioner for Spindle Gearbox
- Dual Speed Gearbox
- Automatic Balancing System
- Tool Kit
- Fanuc System Oi
- Oil / Water Separator
- Heat Exchanger for Electrical Cabinet

Unit	VL-2000ATC	VL-2000ATC+C	VL-2500ATC	VL-2500ATC+C	VL-3000ATC	VL-3000ATC+C
CAPACITY						
Table Diameter	mm	ø2,000	ø2,000	ø2,500	ø2,500	ø3,000
Max. Swing Diameter	mm	ø2,500	ø2,500	ø3,000	ø3,000	ø3,500
Max. Turning Diameter	mm	ø2,300	ø2,300	ø2,800	ø2,800	ø3,400
Max. Turning Height	mm	1,700	1,700	1,700	1,700	1,650
Max. Load on Table	kg	10,000	10,000	15,000	15,000	20,000
#1 SPINDLE						
Spindle Speed – Low	rpm	2~50	2~50	2~43	2~43	2~40
– High		51~200	51~200	44~160	44~160	41~120
Max. Torque	N.m	46,000	46,000	57,000	57,000	64,500
#2 SPINDLE						
Spindle Speed	rpm	N/A	2,400	N/A	2,400	2,400
Max. Torque	N.m	N/A	730	N/A	730	730
TRAVEL / FEEDRATE						
X Axis Travel	mm	2,275	2,275	2,525	2,525	2,775
Z Axis Travel	mm	1,000 (1,400)	1,000 (1,400)	1,000 (1,400)	1,000 (1,400)	1,000 (1,400)
Vertical Travel of Crossrail	mm	1,150	1,150	1,150	1,150	1,200
X Axis Rapid Feedrate	mm/min	10,000	10,000	10,000	10,000	10,000
Z Axis Rapid Feedrate	mm/min	10,000	10,000	10,000	10,000	10,000
Cutting Feedrate	mm/rev	0.01~50	0.01~50	0.01~50	0.01~50	0.01~50
Manual Feedrate	mm/min	0~1,260	0~1,260	0~1,260	0~1,260	0~1,260
TOOLING						
No. of Tools		12 Tools	16 Tools	12 Tools	16 Tools	12 Tools
Type of Tool Shank		BT50	BT50	BT50	BT50	BT50
Max. Tool Weight	kg	50	50	50	50	50
Max. Loading of ATC	kg	360	450	360	450	360
Tool Change Time (ATC)	sec	30	30	45	45	45
MOTOR						
#1 Spindle Motor (Cont/30min)	kw	60/75 (75/100)	60/75 (75/100)	60/75 (75/100)	60/75 (75/100)	60/75 (75/100)
#2 Spindle Motor (Cont/30min)	kw	N/A	11/15	N/A	11/15	N/A
X Axis Servo Motor	kw	7.0	7.0	7.0	7.0	7.0
Z Axis Servo Motor	kw	7.0	7.0	7.0	7.0	7.0
CF Axis Servo Motor	kw	N/A	7.0	N/A	7.0	7.0
Crossrail Hoist Motor	kw	3.75	3.75	3.75	3.75	3.75
Hydraulic Motor	kw	3.75	3.75	3.75	3.75	3.75
Conveyor Motor	kw	0.375	0.375	0.375	0.375	0.375
Coolant Pump	kw	2.2+1.1	2.2+1.1	2.2+1.1	2.2+1.1	2.2+1.1
CAPACITY						
Hydraulic Tank	Liter	130	130	130	130	130
Coolant Tank	Liter	700	700	1,100	1,100	1,100
MACHINE BODY						
Machine (L1 x W1)	mm	4,950 x 7,320	4,950 x 7,320	5,400 x 7,570	5,400 x 7,570	6,100 x 8,700
Machine (H1)	mm	6,600	6,600	6,600	6,600	6,700
Machine Weight	kg	51,000	52,000	53,000	54,000	68,000
Power Requirement	kva	140	150	140	150	150

Optional Accessories

- 3/6 Jaw Power Chuck
- 3 or 4 Power Chuck + Hand Chuck
- ATC 16T / 30T / 60T / 90T
- Grinding Function
- Paper Filter
- Crossrail Navigation System
- Power Jaw / Hand Jaw
- Coolant Through Spindle
- Linear Encoder of X/Z Axis
- Hirth Coupling Tool System
- Z-Axis Special Travel
- #1 Spindle Motor
- Automatic Door
- Gearbox for X/Z Axis Servo Motor
- Transformer
- Active Tool Checking
- Active Workpiece Checking
- Tool Holder
- Fanuc System 18i / 32i
- Siemens System 810 / 840
- Custom Color Option
- Automatic Pallet Changer
- CE Mark
- Air Conditioner for Electrical Cabinet