

KINWA

金和車床

金和CNC平台式車床

KINWA FLAT BED CNC LATHE

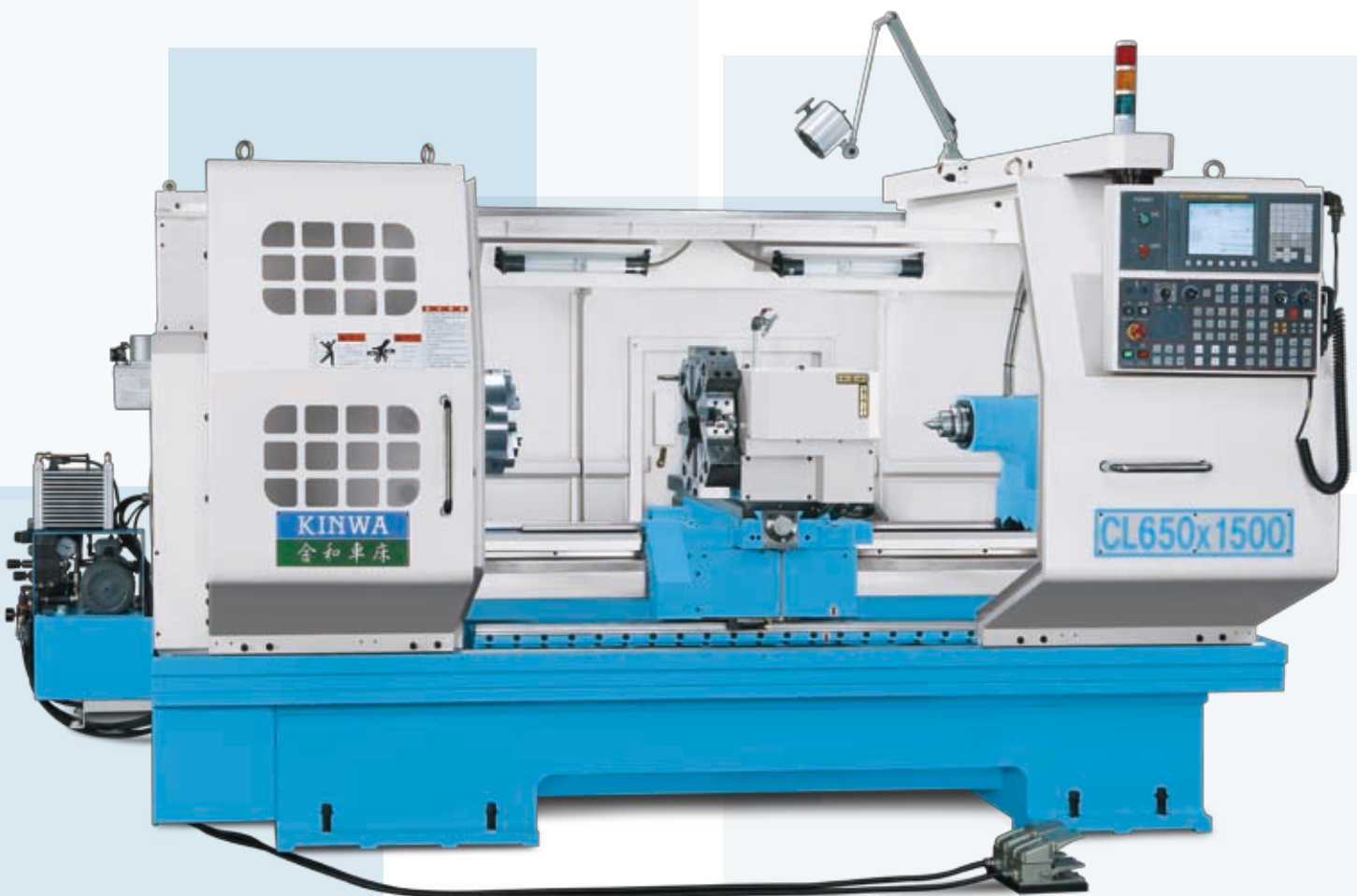

CL-560/650 系列Series

旋徑Swing 560, 660mm

兩心間距Between centers 1350, 2100mm

主軸孔徑Spindle bore 90,104mm

主軸馬達Spindle motor 15HP

KINWA

金和車床

CL-650x1500,CL-650x2300

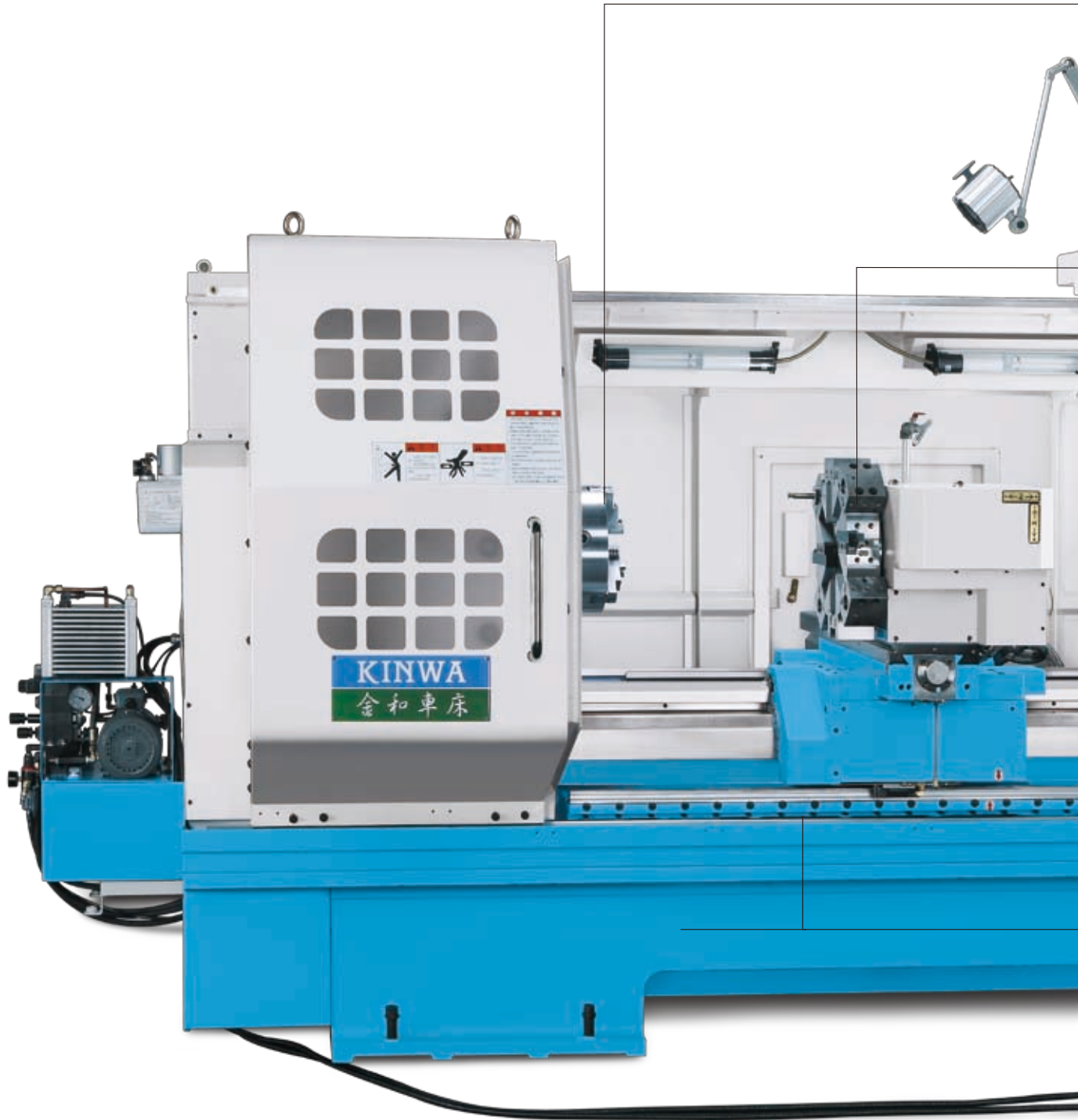



主軸Spindle

- 搭配油壓夾頭時，主軸孔 90mm。
- 搭配手動夾頭時，主軸孔 104mm。
- 2檔手動或自動變速，轉速 3~1600rpm。
- Spindle bore 90mm for hydraulic chuck.
- Spindle bore 104mm for manual chuck.
- 2-gear speed shifted by manual or automatic, speed 3~1600rpm.

刀塔Turret

- 標準為 V8 立式油壓刀塔。
- 可依加工需求，選購手動四方刀架或快換刀架。
- Vertical 8-station hydraulic turret as standard.
- Depends on the work-piece, manual 4-way tool post or quick change tool post as option.

雙門式鈹金Double door

- 標準為雙門式鈹金。
- 可選購尾座全罩式鈹金。
- Double door as standard.
- Full cover of tailstock as option.

腳座Leg base

- 一體式腳座及鞍座線軌支持，提供更佳的剛性。
- One-piece leg base and linear guide supporter provide best rigid.

CL560 / CL650 搭配 β i18 主軸扭力圖

低速檔扭力圖 (Low Gear)

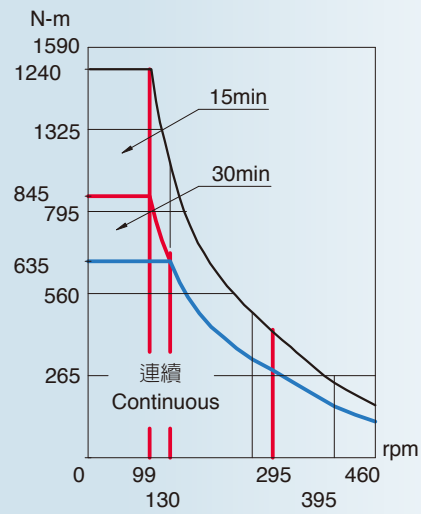
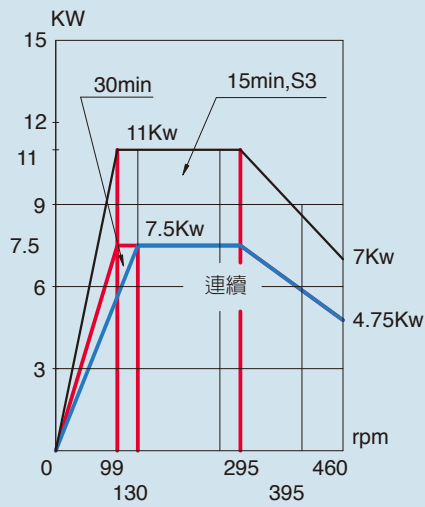

高速檔扭力圖 (High Gear)

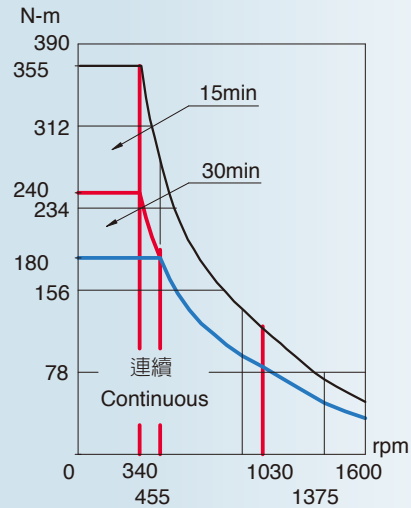
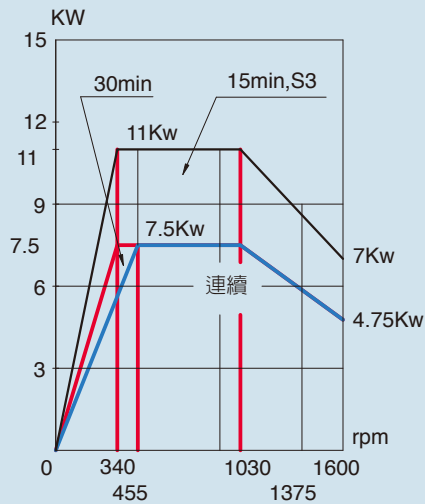

- 2檔手動變速
- 2-gear speed shifted by manual.
- 集中式潤滑油系統
- Center lubrication system.
- 懸吊式油壓箱，沒有搬運及安裝的問題
- Hydraulic tank within the machine, without problem of movement and installation.

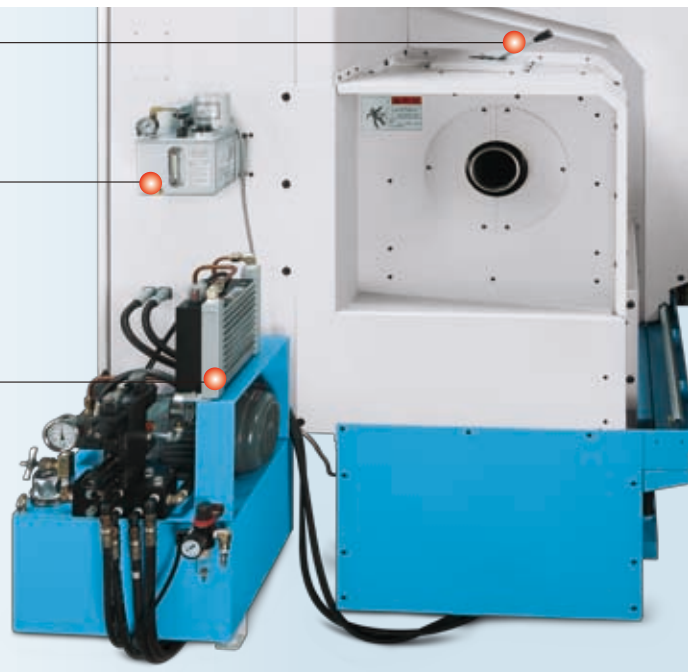

CL650 X行程圖 搭配 CLT80-V8刀塔

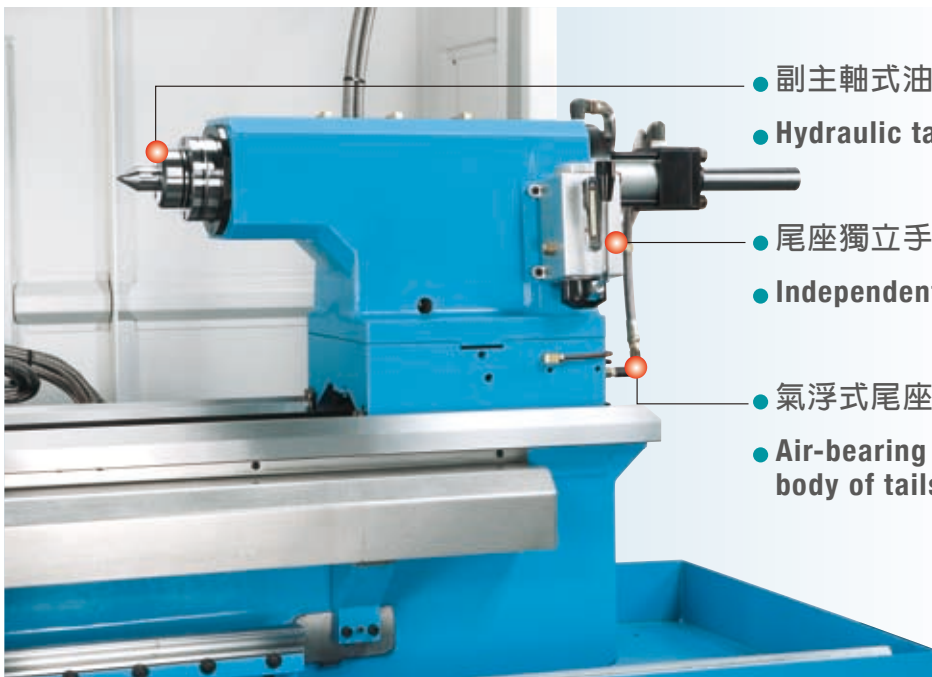
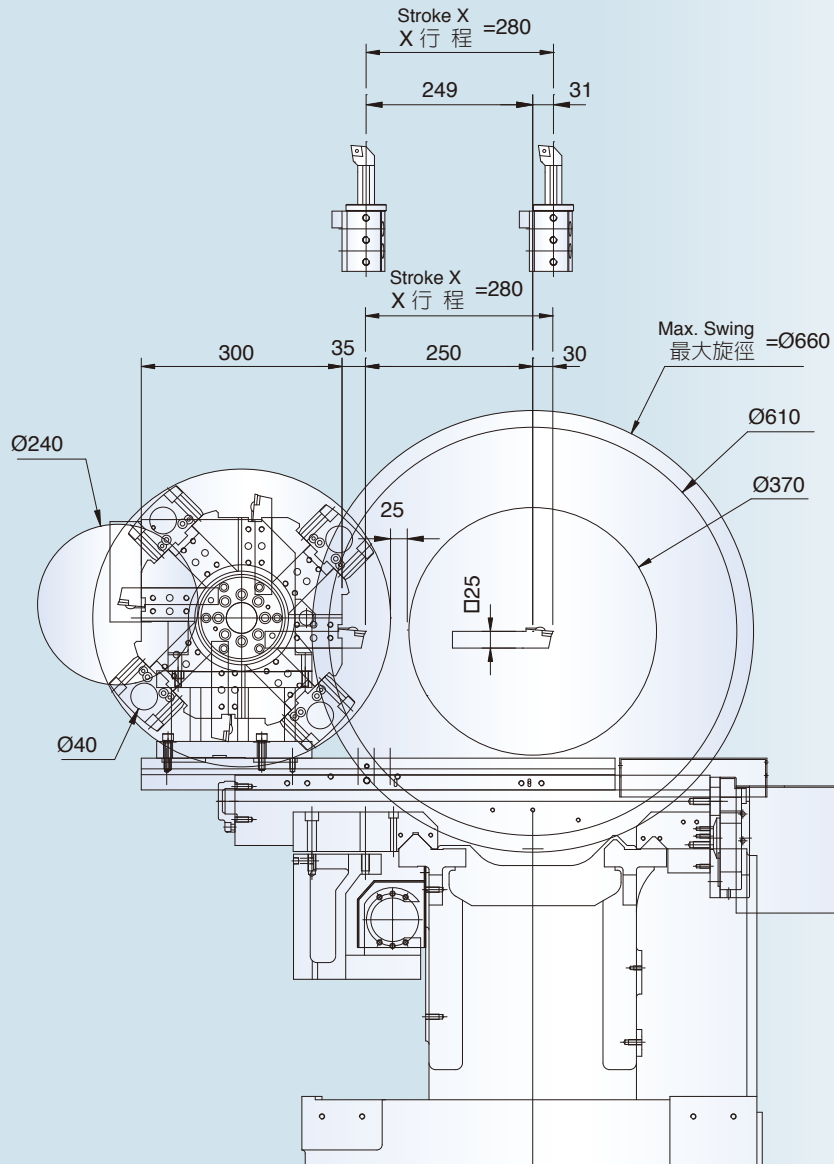

- 副主軸式油壓心軸尾座
- Hydraulic tailstock with built-in-center.
- 尾座獨立手動潤滑系統
- Independent manual lubrication system.
- 氣浮式尾座, 可以輕鬆移動尾座本體
- Air-bearing tailstock easily to move the body of tailstock.

CL560/CL650 Z行程圖 手動四方刀架搭配MT5手動尾座

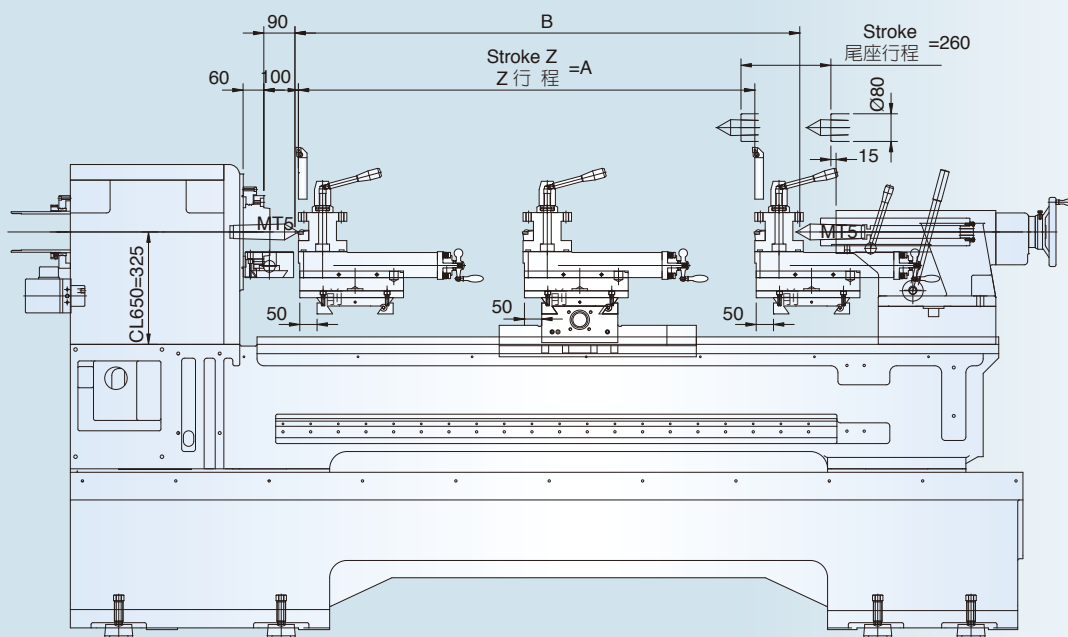

尺寸 \ 機種	CL560x1500	CL650x1500	CL560x2300	CL650x2300
A	1260		2060	
B		1460		2210

CL560/CL650 Z行程圖 搭配MT4油壓副主軸尾座

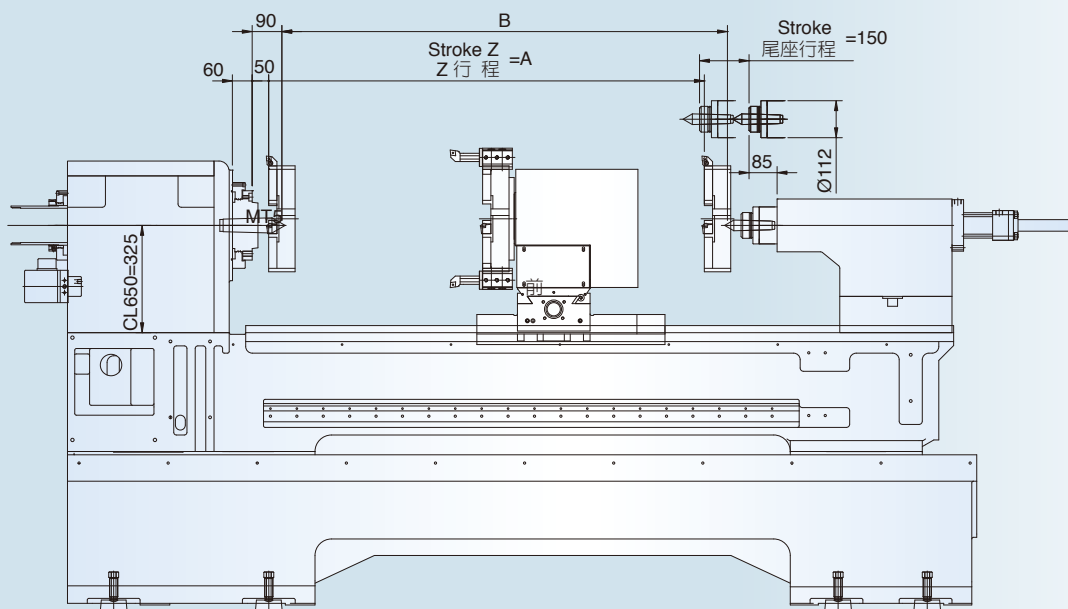

尺寸 \ 機種	CL560x1500	CL650x1500	CL560x2300	CL650x2300
A	1260		2060	
B		1350		2100

配備及附件 Equipment & accessories

- 電腦FANUC 0i TF **F**
 - 彩色螢幕 8.4"
 - 主軸馬達15HP, β il8
 - 主軸孔徑 90mm (搭配油壓夾頭時)
 - 主軸孔徑104mm(搭配手動夾頭時)
 - 中空油壓三爪夾頭10吋或12吋(棒材通孔75mm)
 - 手動三爪連動夾頭12吋或16吋
 - 手動四爪單動夾頭18吋或20吋
 - 立式V8刀塔, 刀具座及刀套
 - 手動四方刀架
 - 快換刀架
 - 軸承中心架 \varnothing 40-255mm
 - 軸承中心架 \varnothing 190-405mm
 - 副主軸式尾座(油壓心軸)及固定頂針MT#4
 - 手動尾座及活動頂針MT#5
 - 跟刀架 \varnothing 30-186mm(只適用於CL-650)
 - 油壓系統
 - 冷卻水槽及冷卻系統
 - 鐵屑輸送機
 - 雙門及擋屑板
 - 工作燈
 - 工具箱及調整工具
 - 變壓器
- Controller FANUC 0i TF
 - Color LCD 8.4"
 - Spindle motor 15HP, β il8
 - Spindle bore 90mm (For hydraulic chuck)
 - Spindle bore 104mm (For manual chuck)
 - 3-jaw hollow hydraulic chuck 10" or 12" (Bar capacity 75mm)
 - 3-jaw manual scroll chuck 12" or 16"
 - 4-jaw manual independent chuck 18" or 20"
 - Vertical 8-station turret, tool holders & sockets
 - Manual 4-way tool post
 - Quick change tool post
 - Steady rest with roller jaw \varnothing 40-255mm
 - Steady rest with roller jaw \varnothing 190-405mm
 - Tailstock with built-in-center (Hydraulic quill) & Dead center MT#4
 - Manual tailstock & Living center MT#5
 - Follow rest \varnothing 30-186mm (Only for CL-650)
 - Hydraulic system
 - Coolant pan & Coolant system
 - Chip conveyor
 - Double door & Splash guard
 - Work Light
 - Tool box with adjusting tool
 - Transformer

▲ 標準或選購依報價單為主 Standard or optional depends on quotation.

外觀尺寸圖(Dimensional drawing)

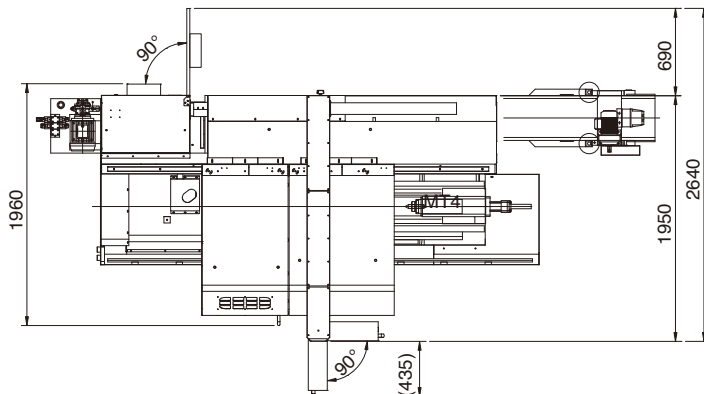

機種	尺寸	A	B
CL560x1500		4010	4930
CL650x1500			
CL560x2300		4770	5690
CL650x2300			

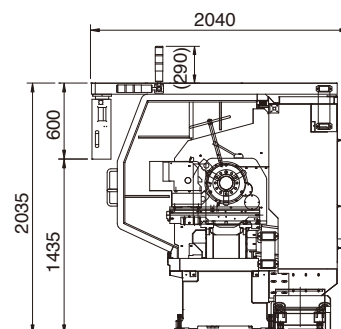
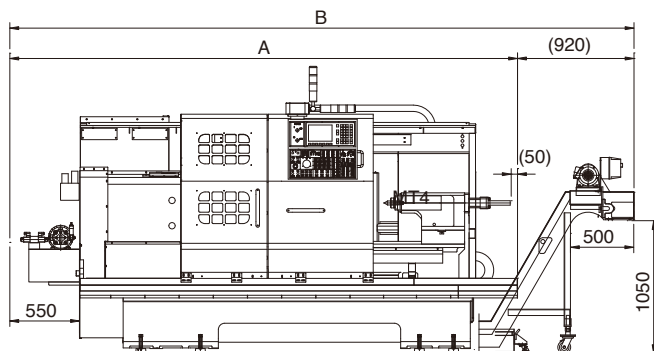

規格Specifications

(CL-650, 1500, 2300)

項目Item		CL-650	
容量 Capacity	最大旋徑 Max. Swing	660mm	
	鞍面旋徑 Swing over carriage	370mm	
	床面寬度 Width of bed	400mm	
	兩心間距 Distance between center	1350, 2100mm ^{*1}	
	控制器 Controller	FANUC Oi TF	
移動量 Stroke	X軸 X axis	280mm	
	Z軸 Z axis	1260, 2060mm	
主軸 Spindle	轉速 Speed (2檔/2 gears)	3~1600rpm	
	主軸鼻端 Spindle nose	A2-8	
	主軸通孔 Spindle bore	90, 104mm ^{*2}	
刀塔 Turret	刀塔型式 Turret type	V8	
	外徑切削刀具 OD tool shank	25mm	
	內徑切削刀具(最大) ID tool shank (Max.)	40mm	
進給速度 Feed traverse	X軸 X axis	8m/min	
	Z軸 Z axis	8m/min	
副主軸油壓尾座 Hydraulic Tailstock with built-in-center	心軸直徑 Quill diameter	112mm ^{*3}	
	心軸斜度 Quill taper	MT#4 ^{*3}	
	心軸移動量 Quill stroke	150mm ^{*3}	
馬達 Motor	主軸馬達 Main motor (15分定格15 min.)	15HP/11kw	
	伺服馬達 Servo motor	1.6HP/1.2kw	
	切削液馬達 Coolant pump motor	1/2HP/0.375kw	
機械尺寸 Machine dimension	機械高度 Height	2035mm	
	佔地面積 Floor space	4930, 5690x2040mm	
	機械重量 Weight	4100, 5100kgs	4200, 5200kgs

▲ 以上規格如有變更恕不另行通知 Specifications are subject to change without notice.

▲ 機械長度不含鐵屑輸送機 Machine length is not including chip conveyor.

▲ 詳細規格數據依報價為主 Detail specification depends on quotation.

*1 上述數據為搭配副主軸油壓尾座時的兩心間距, 若使用手動尾座時, 分別為 1460, 2210mm.

Above between center is for hydraulic tailstock with built-in-center. If use manual tailstock, the between center is 1460, 2210mm.

*2 搭配油壓夾頭時, 主軸孔徑90mm; 搭配手動夾頭時, 主軸孔徑104mm.

The spindle bore is 90mm with hydraulic chuck and the one is 104mm with manual chuck.

*3 上述數據為搭配副主軸油壓尾座時的規格尺寸, 若使用手動尾座時, 心軸直徑為80mm, 心軸斜度MT#5, 心軸移動量260mm.

Above the specification of tailstock is for hydraulic tailstock with built-in-center. If use manual tailstock, the quill diameter is 80mm, quill taper is MT#5 and quill stroke is 260mm.

