

# Mag **V**ise Magnetic Workholding

## **EEPM**

Electro-Permanent Magnetic Chuck

## **ECB**

Permanent Magnetic Clamping Block

# EARTH-CHAIN

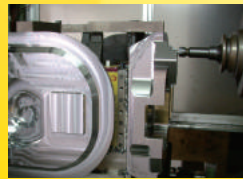
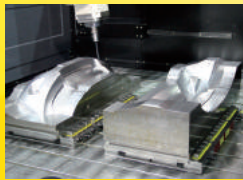
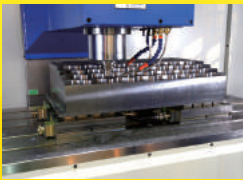



**EARTH-CHAIN ENTERPRISE CO., LTD.**

 **Taiwan**  
Corporation

## **Professional Manufacturer of Magnetic Tools**

Earth-Chain Enterprise was established in 1988, specializing in manufacturing magnetic tools for industrial applications, which are marketed around the world under ECE brand. Owns various patented technologies and products under continuous developments for innovations and improvements as well as with over 40 patents. At present, the customized products have reached more than 50%, providing customers with the most complete product application technology.

Develop MagVise magnetic workholding system is suitable for CNC vertical and horizontal Machining Center, Double Column machining center, vertical and horizontal Lathe and Quick Mold change system for plastic injection machine to improve productive efficiency for customers.

In response to the needs of the CNC automation market, Earth-Chain develops the human-machine interface touch screen built-in intelligent IC signal feedback device, the programmable driven machine tool integrates the magnetic clamping system and links with the robot arm device to reduce the labor time and operation complexity required for future industrial applications.

Prospecting toward the future, Earth-Chain introduces Industry 4.0 to actively invest the market in the supply chain and continuously provide excellent products and services for industrial users, who will advance with us to promote businesses and social improvements for sustainable developments.

## Magnetic Workholding

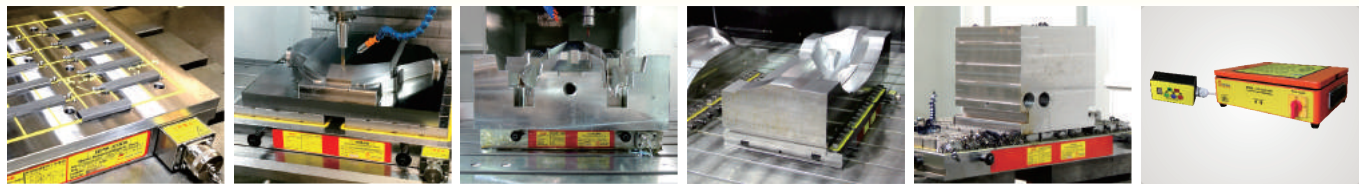

4

5

6

7

8

9

**Electro-Permanent Magnetic Chuck EEPM-A Series** Pole Size 35x35 mm, Flux Line 15 mm  
Suitable for thin, small and medium workpiece on light duty machining.

4

**Electro-Permanent Magnetic Chuck EEPM-B Series** Pole Size 50x50 mm, Flux Line 25 mm  
Suitable for small and medium workpiece machining.

5

**Electro-Permanent Magnetic Chuck EEPM-BF Series** Pole Size 50x50 mm, Flux Line 25 mm  
Suitable for medium and large workpiece machining.

6

**Electro-Permanent Magnetic Chuck EEPM-D Series** Pole Size 70x70 mm, Flux Line 40 mm  
Suitable for medium and large workpiece on heavy duty machining.

7

**Electro-Permanent Magnetic Chuck EEPM-E Series** Pole Size 92x92 mm, Flux Line 50 mm  
Suitable for medium and large workpiece on heavy duty machining.

8

**Option Controller EEPM-C Series**  
Option controller available for control multi-EEPM chuck.

9

**Human Machine Interface controller EEPM-HMI Series**  
Suitable for use on EEPM Series of Electro-Permanent Magnetic Chuck.

11

**Induction Block EEPM-IB Series**  
Suitable for Increased using life of magnetic chuck

12

**Induction Block EEPM-IBT & EEPM-IBV Series**  
Suitable for slope finishing of workpiece machining

14

**Spring Block EEPM-SP Series**  
Suitable for clamping on iron cast, irregular form and flexuous workpieces

15

**Induction Sub Plate EEPM-ISP Series**  
Suitable for quantity of irregular and smaller workpiece

15

**Other Option Accessories**  
Suitable for use on EEPM Series of Electro-Permanent Magnetic Chuck.

16

**Electro-Permanent Magnetic Chuck EEPM-SL/TA Series**  
Can be use together with mechanical clamping tools

18

11

12

14

15

15

18

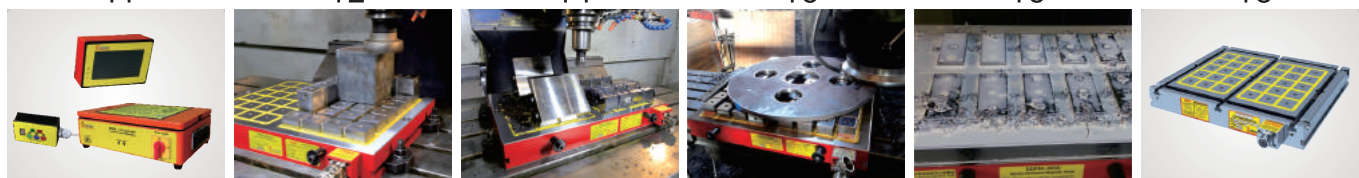



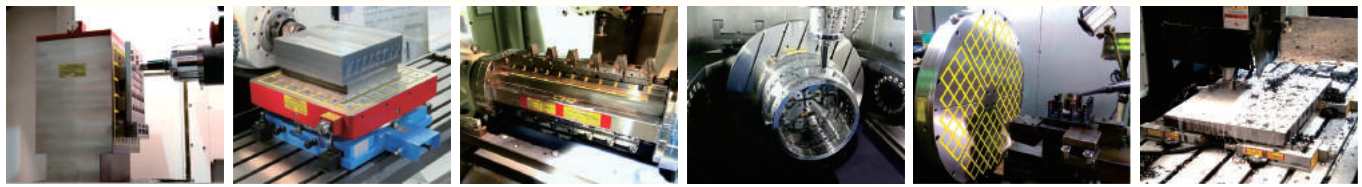

19

21

23

25

31

37

**Electro-Permanent Magnetic Chuck EEPM-V Series**  
Suitable for CNC horizontal machining center

19

**Electro-Permanent Magnetic Chuck EEPM-IT Series**

Suitable for horizontal milling & boring machine on precision machining of division.

21

**Electro-Permanent Magnetic Chuck EEPM-CIT Series**

Suitable in use for combine with CNC 4 Axis Index Device

23

**Electro-Permanent Magnetic Chuck EEPM-CIRA & EEPM-CIR Series**

Suitable for use on Vertical Lathe, CNC 5 Axis Machining Center ...etc

25

**Electro-Permanent Magnetic Chuck EEPM-CIRSA & EEPM-CIRS Series**

Suitable in use for combine with Rotary type Surface Grinding Machine, CNC 5 Axis Machining Center ... etc.

31

**Electro-Permanent Magnetic Chuck-Connection Type EEPM-C Series**

Suitable for use on large Vertical Lathe, Double Column Machining Center and CNC Machining Center ...etc.

37

**Custom-Made EEPM Chucks**

Custom-chucks built to yor specification

43

**Electro-Permanent Magnetic Chuck EEPML Series (Custom-made)**

Used on Linear Guideway high precision or high accuracy long strip workpiece drilling, grinding machining...etc.

45

**Electro-Permanent Magnetic Chuck EEPM-PiM Series (Custom-made)**

Quick Mold Change Systems for Plastic Injection Machine

47

**Electro-Magnetic ECM Series**

Suitable for Automatic Robotic Arm clamping

51

**Electro-Permanent Magnetic Chuck EPSM Series**

Suitable for Automatic Robotic Arm clamping

52

**Permanent Magnetic Clamping Block ECB Series**

Suitable for use on large Vertical Lathe, Double Column Machining Center and CNC Machining Center ...etc.

53

**Permanent Magnetic Clamping Block ECB-120V12 Series**

Suitable for use on CNC Horizontal Machining Center.

58

43

45

47

51

52

53







earth-chain.com

Website



APP

Mobile & Tablet APP



YouTube

YouTube Video



facebook

Facebook



LINE

LINE Service

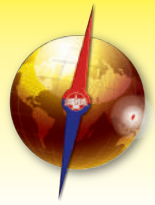

■ Suitable for CNC Vertical machining center (Can do 5 sides machining)

### Magnetic force of EEPМ Chucks

The Magnetic forces will change depending on the thickness, attractive face roughness and quality of material and clearance between the workpiece with EEPМ Chucks.  
(See as the graphs as below)

Chart of difference in Magnetic force by thickness

|     | Thickness |          | Percentage of Magnetic force |        |        |        |     |   |
|-----|-----------|----------|------------------------------|--------|--------|--------|-----|---|
|     | mm        | inch     | EEPМ-A                       | EEPМ-B | EEPМ-D | EEPМ-E |     |   |
| T1  | up 50     | up 1.97" | 100%                         | 100%   | 100%   | 100%   |     |   |
| T2  | 45        | 1.77"    |                              |        |        | 90%    |     |   |
| T3  | 40        | 1.57"    |                              |        |        | 80%    |     |   |
| T4  | 35        | 1.38"    |                              |        |        | 90%    | 70% |   |
| T5  | 30        | 1.18"    |                              |        |        | 80%    | 55% |   |
| T6  | 25        | 0.98"    |                              |        |        | 65%    |     |   |
| T7  | 20        | 0.79"    |                              |        |        | 90%    | 45% |   |
| T8  | 15        | 0.59"    |                              |        |        | 70%    |     | — |
| T9  | 10        | 0.39"    |                              |        |        | 85%    | 40% | — |
| T10 | 5         | 0.20"    |                              |        |        | 35%    | —   |   |

Chart of difference in Magnetic force by attractive face roughness.  
For all EEPМ Series

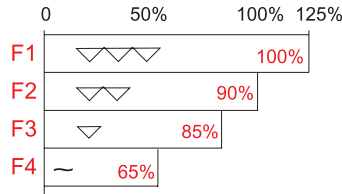
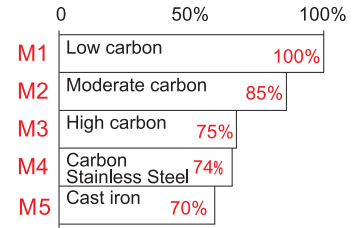

Chart of difference in Magnetic force by material quality.  
For all EEPМ Series



Calculating Formula for "Magnetic force" → (TxFxMxCapacity of Magnetic force)

Example of EEPМ-D Series:

Terms of workpiece: T4, F2 and M2

90% x 90% x 85% x 2800±5% kgf/4 Poles = 1928±5% Kg/4 Poles

Comparison chart of Maximum magnetic forces and workpiece thickness

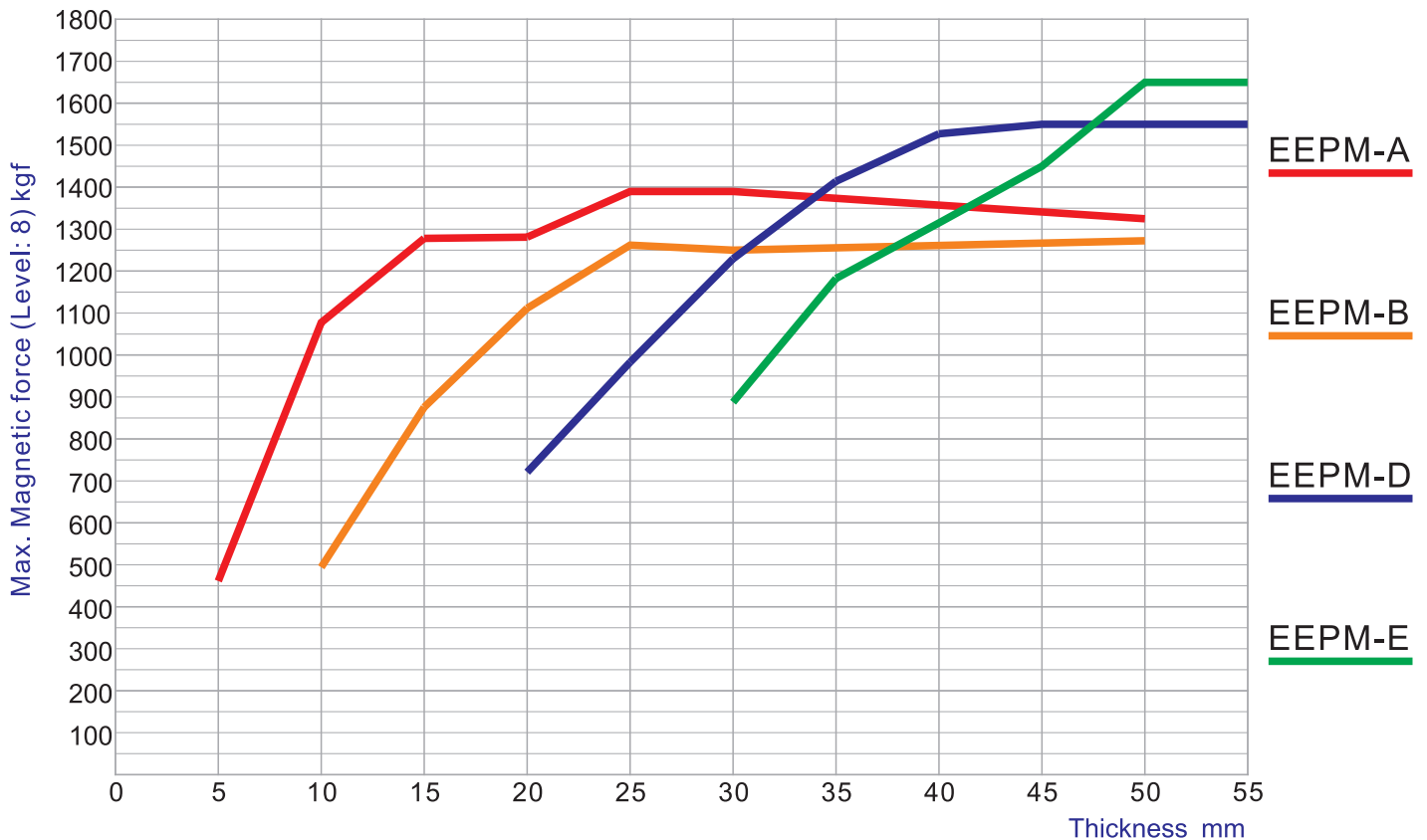

1. Test workpiece: Maximum magnetic force of workpiece of 120X120 mm<sup>2</sup> area
2. EEPМ-A Series: Flux line: 15mm, Workpiece thickness suggestion: 25mm ↓  
EEPМ-B Series: Flux line: 25mm, Workpiece thickness suggestion: 15~50mm  
EEPМ-D Series: Flux line: 40mm, Workpiece thickness suggestion: 30mm ↑  
EEPМ-E Series: Flux line: 50mm, Workpiece thickness suggestion: 40mm ↑

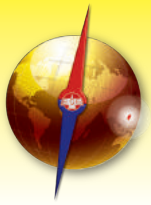

# Mag Vise

## Electro-Permanent Magnetic Chuck EPPM-A 、EPPM-B 、EPPM-D 、EPPM-E Series

**Magnetic Workholding** ■ Suitable for CNC Vertical machining center (Can do 5 sides machining)

### Features:

1. 1-2 seconds control for power ON & OFF. No electric power supply required to keep magnetic chuck ON and provides maximized safety in case of power failure. Never get temperatures to affect the accuracy of workpieces.
2. With 8 Magnetic levels for different workpiece size and application to avoid sticking the iron chip.
3. Capable for 5 sides machining and un-obstructed cutter movement during machining. Allow workpiece machining finished in one cycle, while still achieving best machining accuracy and highly increased working efficiency.
4. Easy and convenient to clamp a workpiece, shortens clamping time.
5. Minimum size of workpiece required as 4 alternate magnetic square poles and above contacts is necessary for optimum clamping.
6. More functions for cooperate with Induction Block and Spring Block. (See the detail of Option Accessories)

### Specification of poles size & Height of magnetic field (Flux Line):

EPPM Chucks are designed for different mold thickness. Specify the mold to be Large, Medium and Small sizes make 4 poles sizes, bigger pole size with higher flux line. Different pole sizes have different magnetic field height (flux line) to ensure mold clamping safety.

EPPM-A Series Flux Line 15 mm, Pole Size 35x35 mm  
Magnetic force: 580 ±5% Kg/4 poles

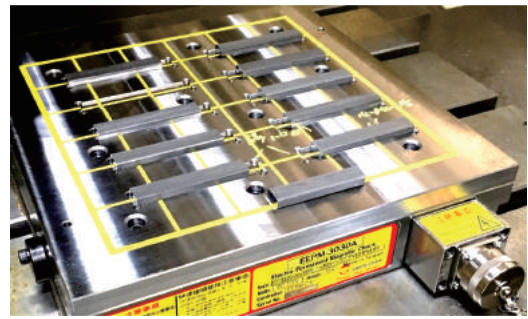
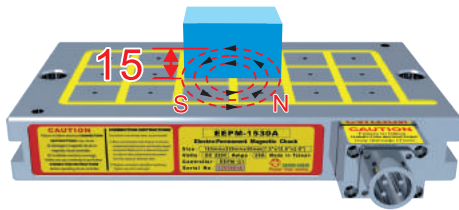

EPPM-B Series Flux Line 25 mm, Pole Size 50x50 mm  
Magnetic force: 1250 ±5% Kg/4 poles

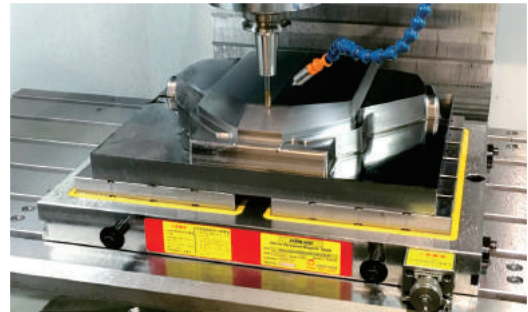

EPPM-D Series Flux Line 40 mm, Pole Size 70x70 mm  
Magnetic force: 2800 ±5% Kg/4 poles

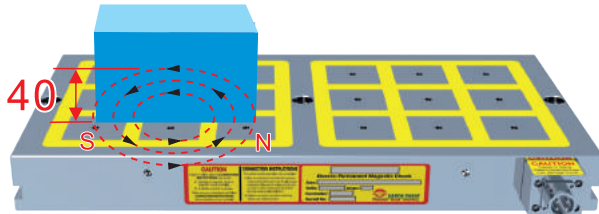

EPPM-E Series Flux Line 50 mm, Pole Size 92x92 mm  
Magnetic force: 4800 ±5% Kg/4 poles

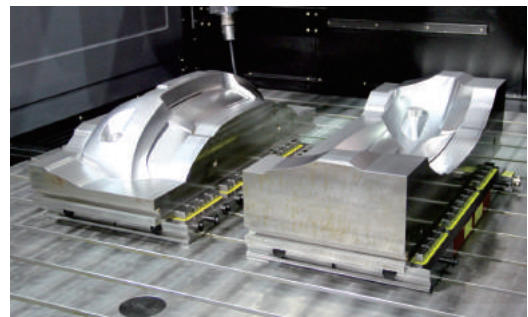
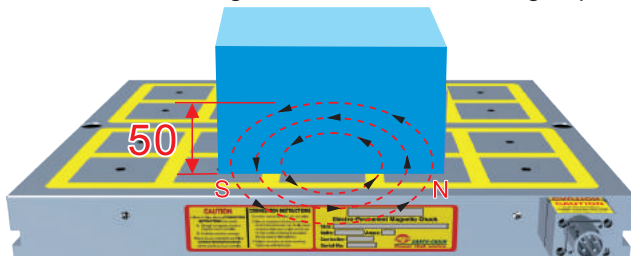



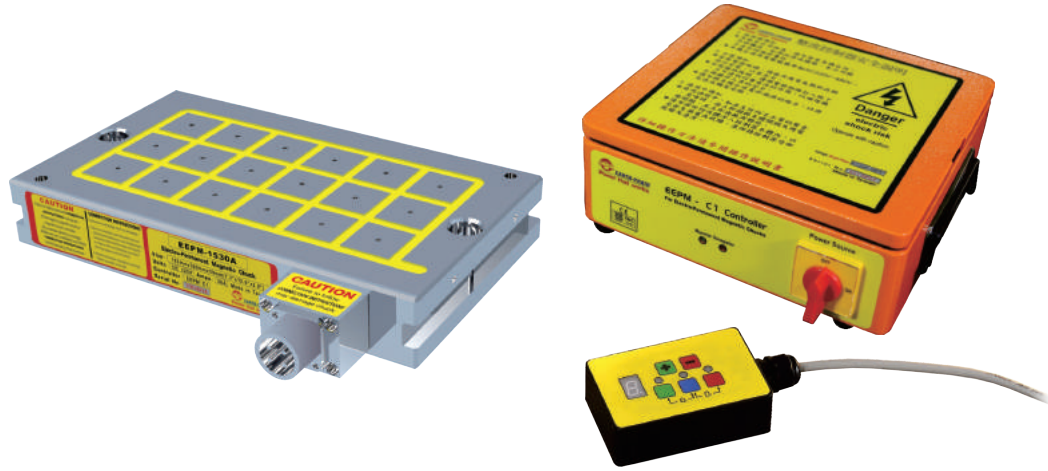

Pole 35X35 mm, Flux Line 15 mm, Magnetic Force 580±5% kgf/4 Poles

**Applications:**

1. Suitable for thin, small and medium workpiece on light duty machining.
2. Suitable for thin, small and medium workpiece of the drilling and finishing machining.
3. Minimum size of workpiece required as 4 alternate magnetic square poles and above contacts is necessary for optimum clamping.
4. More functions for cooperate with Induction Block and Spring Block. (See the detail of Option Accessories)

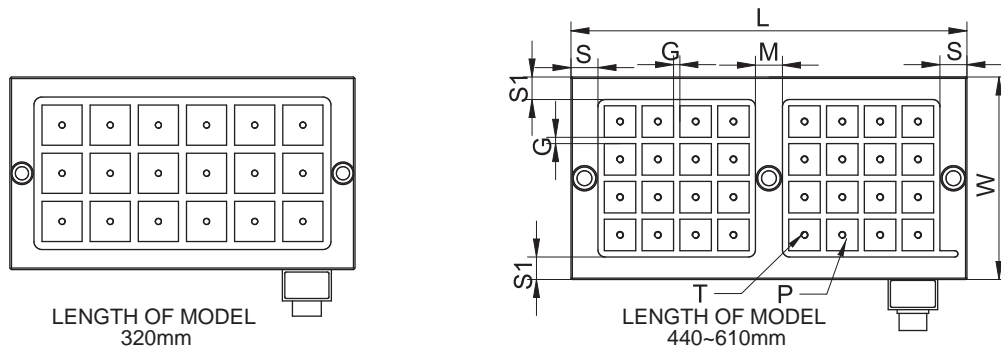

Unit:mm

| MODEL NO.   | DIMENSION |     |      |      |    |    |    | PITCH G | POLE P | NO. OF POLE | Unipolar suction kgf ±5% | TOTAL HOLDING POWER kgf ±5% | CHUCK N.W.      | VOLTAGE (Single Phase) | CURRENT AMP | CONTROLLER (included) |
|-------------|-----------|-----|------|------|----|----|----|---------|--------|-------------|--------------------------|-----------------------------|-----------------|------------------------|-------------|-----------------------|
|             | W         | L   | S    | S1   | M  | T  | H  |         |        |             |                          |                             |                 |                        |             |                       |
| EEPMA-1530A | 185       | 320 | 30.5 | 26   | -  |    |    |         | 18     |             | 2610                     | 23kg                        | AC 220V<br>480V | 18A                    | C1          |                       |
| EEPMA-2540A | 225       | 440 | 30   | 25   | 30 |    |    | 32      |        | 4640        | 39kg                     | 30A                         |                 | C1                     |             |                       |
| EEPMA-2560A | 225       | 610 | 31   | 25   | 30 |    |    | 48      |        | 6960        | 54kg                     | 26A                         |                 | C2                     |             |                       |
| EEPMA-3030A | 310       | 320 | 30.5 | 25.5 | -  |    |    | 36      |        | 5220        | 39kg                     | 26A                         |                 | C1                     |             |                       |
| EEPMA-3040A | 310       | 440 | 30   | 25.5 | 30 | M6 | 50 | 7       | 35x35  | 48          | 145                      | 6960                        |                 | 53kg                   | 25A         | C2                    |
| EEPMA-3060A | 310       | 610 | 31   | 25.5 | 30 |    |    | 72      |        | 10440       | 74kg                     | 31A                         |                 | C2                     |             |                       |
| EEPMA-4040A | 435       | 440 | 30   | 25   | 30 |    |    | 72      |        | 10440       | 75kg                     | 31A                         |                 | C2                     |             |                       |
| EEPMA-4050A | 435       | 525 | 30.5 | 25   | 30 |    |    | 90      |        | 13050       | 90kg                     | 24A                         |                 | C4                     |             |                       |
| EEPMA-4060A | 435       | 610 | 31   | 25   | 30 |    |    | 108     |        | 15660       | 104kg                    | 26A                         |                 | C4                     |             |                       |

Custom-made is available.

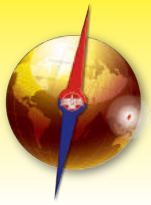

**Mag Vise**

**Electro-Permanent Magnetic Chuck EEPM-B Series**

**Magnetic Workholding**

■ Suitable for CNC Vertical machining center (Can do 5 sides machining)

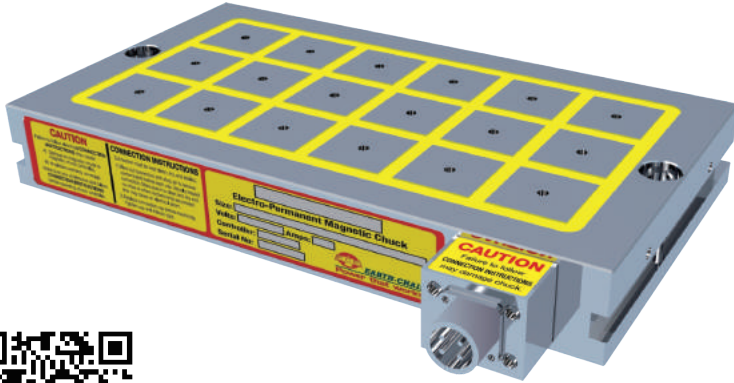

Pole 50X50 mm, Flux Line 25 mm, Magnetic Force 1250±5% kgf/4 Poles

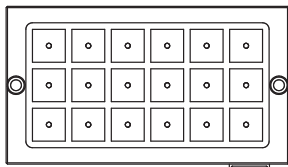

LENGTH OF MODEL  
300~400mm

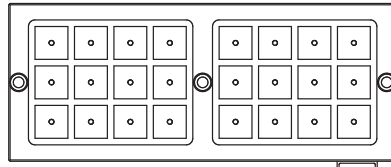

LENGTH OF MODEL  
600mm

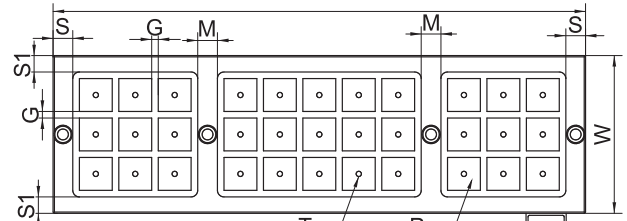

LENGTH OF MODEL  
800mm and above

Unit:mm

| MODEL NO.   | DIMENSION |     |    |    |    |    |    |    | PITCH<br>G | POLE<br>P | NO. OF<br>POLE | TOTAL HOLDING<br>POWER kgf ±5% | CHUCK<br>N.W. | VOLTAGE<br>(Single Phase) | CURRENT<br>AMP | CONTROLLER<br>(included) | VOLTAGE<br>(Single Phase) | CURRENT<br>AMP | CONTROLLER<br>(included) |
|-------------|-----------|-----|----|----|----|----|----|----|------------|-----------|----------------|--------------------------------|---------------|---------------------------|----------------|--------------------------|---------------------------|----------------|--------------------------|
|             | W         | L   | S  | S1 | M  | T  | H  |    |            |           |                |                                |               |                           |                |                          |                           |                |                          |
| EEPМ-2540B  | 240       | 430 | 30 | 25 | -- |    |    |    |            | 18        | 5600           | 50kg                           |               | 18A                       | C1             |                          | 16A                       | C1             |                          |
| EEPМ-2560B  | 240       | 590 | 30 | 25 | 30 |    |    |    |            | 24        | 7500           | 69kg                           |               | 30A                       | C1             |                          | 12A                       | C1             |                          |
| EEPМ-2580B  | 240       | 810 | 30 | 25 | 30 |    |    |    |            | 33        | 10300          | 92kg                           |               | 30A                       | C1             |                          | 19A                       | C1             |                          |
| EEPМ-2590B  | 240       | 870 | 30 | 25 | 30 |    |    |    |            | 36        | 11200          | 98kg                           |               | 18A                       | C2             |                          | 18A                       | C1             |                          |
| EEPМ-25100B | 240       | 990 | 30 | 25 | 30 |    |    |    |            | 42        | 13100          | 111kg                          |               | 26A                       | C2             |                          | 14A                       | C2             |                          |
| EEPМ-3030B  | 300       | 310 | 30 | 25 | -- |    |    |    |            | 16        | 5000           | 44kg                           |               | 20A                       | C1             |                          | 8A                        | C1             |                          |
| EEPМ-3040B  | 300       | 430 | 30 | 25 | -- |    |    |    |            | 24        | 7500           | 61kg                           |               | 30A                       | C1             |                          | 12A                       | C1             |                          |
| EEPМ-3060B  | 300       | 590 | 30 | 25 | 30 |    |    |    |            | 32        | 10000          | 82kg                           |               | 30A                       | C1             |                          | 20A                       | C1             |                          |
| EEPМ-3080B  | 300       | 810 | 30 | 25 | 30 |    |    |    |            | 44        | 13700          | 116kg                          |               | 25A                       | C2             |                          | 13A                       | C2             |                          |
| EEPМ-3090B  | 300       | 870 | 30 | 25 | 30 |    |    |    |            | 48        | 15000          | 123kg                          |               | 30A                       | C2             |                          | 12A                       | C2             |                          |
| EEPМ-30100B | 300       | 990 | 30 | 25 | 30 |    |    |    |            | 56        | 17500          | 138kg                          |               | 35A                       | C2             |                          | 19A                       | C2             |                          |
| EEPМ-4040B  | 420       | 430 | 30 | 25 | -- |    |    |    |            | 36        | 11200          | 84kg                           |               | 18A                       | C2             |                          | 18A                       | C1             |                          |
| EEPМ-4050B  | 420       | 490 | 30 | 25 | -- | M8 | 60 | 10 | 50x50      | 42        | 13100          | 95kg                           | AC<br>220V    | 26A                       | C2             | AC<br>380V<br>440V       | 14A                       | C2             |                          |
| EEPМ-4060B  | 420       | 590 | 30 | 25 | 30 |    |    |    |            | 48        | 15000          | 100kg                          |               | 30A                       | C2             |                          | 12A                       | C2             |                          |
| EEPМ-4080B  | 420       | 810 | 30 | 25 | 30 |    |    |    |            | 66        | 20600          | 159kg                          |               | 30A                       | C2             |                          | 19A                       | C2             |                          |
| EEPМ-4090B  | 420       | 870 | 30 | 25 | 30 |    |    |    |            | 72        | 22500          | 169kg                          |               | 18A                       | C4             |                          | 18A                       | C2             |                          |
| EEPМ-40100B | 420       | 990 | 30 | 25 | 30 |    |    |    |            | 84        | 26200          | 193kg                          |               | 26A                       | C4             |                          | 12A                       | C4             |                          |
| EEPМ-5060B  | 480       | 590 | 30 | 25 | 30 |    |    |    |            | 56        | 17500          | 129kg                          |               | 35A                       | C2             |                          | 19A                       | C2             |                          |
| EEPМ-5080B  | 480       | 810 | 30 | 25 | 30 |    |    |    |            | 77        | 24000          | 185kg                          |               | 30A                       | C4             |                          | 13A                       | C4             |                          |
| EEPМ-5090B  | 480       | 870 | 30 | 25 | 30 |    |    |    |            | 84        | 26200          | 196kg                          |               | 26A                       | C4             |                          | 14A                       | C4             |                          |
| EEPМ-50100B | 480       | 990 | 30 | 25 | 30 |    |    |    |            | 98        | 30600          | 219kg                          |               | 30A                       | C4             |                          | 12A                       | C4             |                          |
| EEPМ-6060B  | 600       | 590 | 30 | 25 | 30 |    |    |    |            | 72        | 22500          | 165kg                          |               | 18A                       | C4             |                          | 18A                       | C2             |                          |
| EEPМ-6080B  | 600       | 810 | 30 | 25 | 30 |    |    |    |            | 99        | 30900          | 215kg                          |               | 30A                       | C4             |                          | 19A                       | C4             |                          |
| EEPМ-6090B  | 600       | 870 | 30 | 25 | 30 |    |    |    |            | 108       | 33700          | 240kg                          |               | 27A                       | C4             |                          | 20A                       | C4             |                          |
| EEPМ-60100B | 600       | 990 | 30 | 25 | 30 |    |    |    |            | 126       | 39300          | 274kg                          |               | 32A                       | C4             |                          | 21A                       | C4             |                          |
| EEPМ-8080B  | 755       | 810 | 30 | 25 | 30 |    |    |    |            | 121       | 37800          | 271kg                          |               | 33A                       | C4             |                          | 18A                       | C4             |                          |

Custom-made is available.

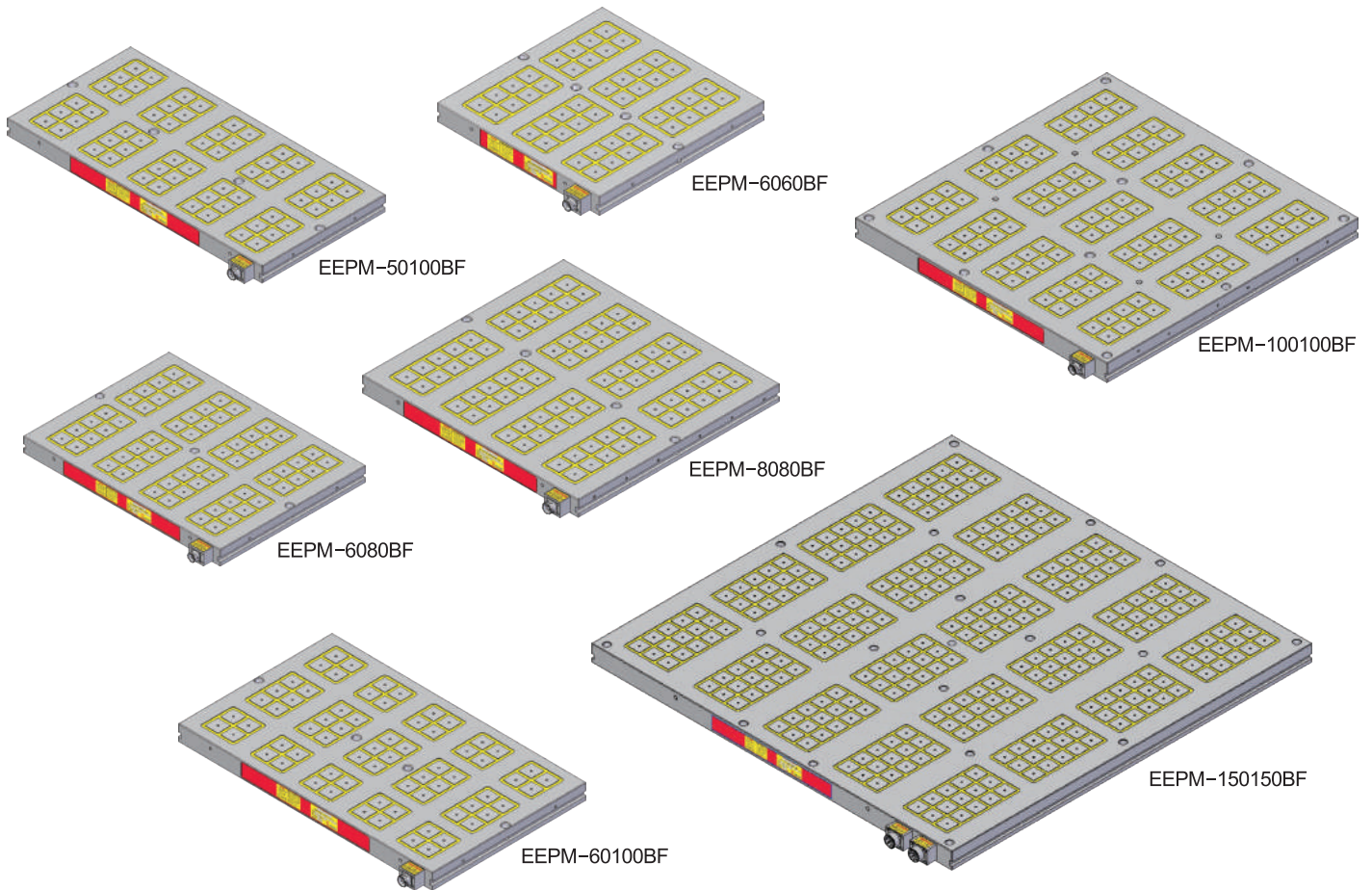
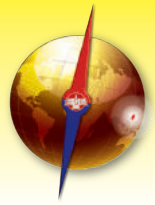

Pole 50X50 mm, Flux Line 25 mm, Magnetic Force 1250±5% kgf/4 Poles

**Applications:**

1. Suitable for medium and large workpiece machining.
2. Suitable for medium and large double column machining center.
3. Make sure the machining quality and security the workpiece dimension of length, width minimum covering required covering 20 poles and thickness must be at least 40mm.
4. More functions for cooperate with induction block and spring block. (See the detail of Option Accessories)

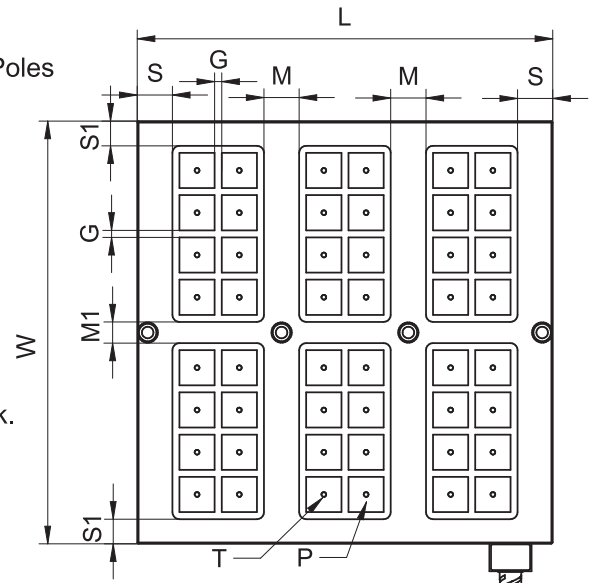

| MODEL NO.     | DIMENSION |      |    |      |     |    |    |    | PITCH<br>G | POLE<br>P | NO. OF<br>POLE | TOTAL HOLDING<br>POWER kgf ±5% | CHUCK<br>N.W. | VOLTAGE<br>(Single Phase) | CURRENT<br>AMP | CONTROLLER<br>(included) | VOLTAGE<br>(Single Phase) | CURRENT<br>AMP | CONTROLLER<br>(included) |
|---------------|-----------|------|----|------|-----|----|----|----|------------|-----------|----------------|--------------------------------|---------------|---------------------------|----------------|--------------------------|---------------------------|----------------|--------------------------|
|               | W         | L    | S  | S1   | M   | M1 | T  | H  |            |           |                |                                |               |                           |                |                          |                           |                |                          |
| EEPМ-50100BF  | 480       | 990  | 50 | 30   | 60  | 40 |    |    |            | 60        | 18750          | 143kg                          | AC<br>220V    | 31A                       | C2             | AC<br>380V<br>440V       | 18A                       | C2             |                          |
| EEPМ-6060BF   | 600       | 590  | 50 | 35   | 50  | 30 |    |    | 48         | 15000     | 196kg          | 30A                            |               | C2                        | 12A            |                          | C2                        |                |                          |
| EEPМ-6080BF   | 600       | 810  | 55 | 35   | 60  | 30 |    | 60 | 64         | 20000     | 246kg          | 33A                            |               | C2                        | 18A            |                          | C2                        |                |                          |
| EEPМ-60100BF  | 600       | 990  | 50 | 35   | 60  | 40 | M8 | 10 | 70         | 21850     | 191kg          | 25A                            |               | C4                        | 14A            |                          | C2                        |                |                          |
| EEPМ-8080BF   | 755       | 810  | 55 | 42.5 | 60  | 50 |    |    | 80         | 25000     | 239kg          | 23A                            |               | C4                        | 14A            |                          | C4                        |                |                          |
| EEPМ-100100BF | 1000      | 1000 | 55 | 60   | 60  | 65 |    |    | 120        | 37500     | 469kg          | 33A                            |               | C4                        | 21A            |                          | C4                        |                |                          |
| EEPМ-150150BF | 1500      | 1500 | 75 | 55   | 100 | 50 |    |    | 300        | 93750     | 1054kg         | 29A                            |               | C12                       | 15A            |                          | C12                       |                |                          |

Custom-made is available.



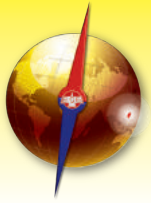

**Mag Vise**

**Electro-Permanent Magnetic Chuck EEPM-D Series**

**Magnetic Workholding**

■ Suitable for CNC Vertical machining center (Can do 5 sides machining)

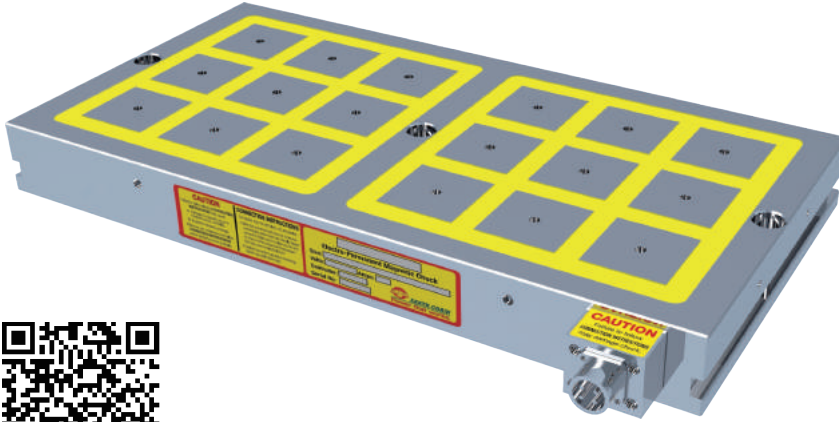

Pole 70X70 mm, Flux Line 40 mm, Magnetic Force 2800±5% kgf/4 Poles

**Applications:**

1. Suitable for medium and large workpiece on heavy duty machining.
2. Suitable for medium and double column machining center.
3. Minimum size of workpiece required as 4 alternate magnetic square poles and above contacts is necessary for optimum clamping.
4. More functions for cooperate with Induction Block and Spring Block. (See the detail of Option Accessories)

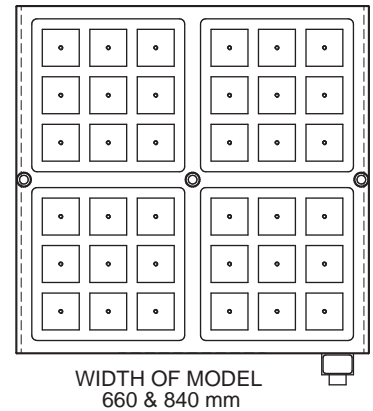
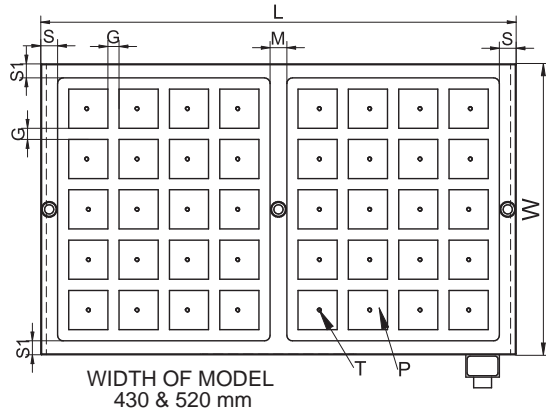
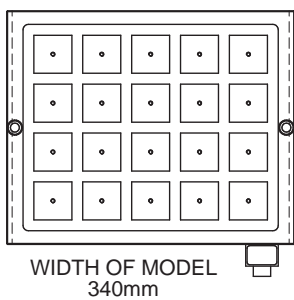

Unit:mm

| MODEL NO.  | DIMENSION |     |    |    |    |     |    | PITCH<br>G | POLE<br>P | NO. OF<br>POLE | Unipolar<br>suction<br>kgf ±5% | TOTAL HOLDING<br>POWER kgf ±5% | CHUCK<br>N.W. | VOLTAGE<br>(Single Phase) | CURRENT<br>AMP | CONTROLLER<br>(included) | VOLTAGE<br>(Single Phase) | CURRENT<br>AMP | CONTROLLER<br>(included) |
|------------|-----------|-----|----|----|----|-----|----|------------|-----------|----------------|--------------------------------|--------------------------------|---------------|---------------------------|----------------|--------------------------|---------------------------|----------------|--------------------------|
|            | W         | L   | S  | S1 | M  | T   | H  |            |           |                |                                |                                |               |                           |                |                          |                           |                |                          |
| EEPМ-3060D | 340       | 670 | 30 | 25 | 30 |     |    |            | 18        |                | 12600                          | 126kg                          |               | 24A                       | C2             |                          | 25A                       | C1             |                          |
| EEPМ-4050D | 430       | 530 | 30 | 25 | -- |     |    |            | 20        |                | 14000                          | 126kg                          |               | 13A                       | C2             |                          | 22A                       | C1             |                          |
| EEPМ-4060D | 430       | 670 | 30 | 25 | 30 |     |    |            | 24        |                | 16800                          | 159kg                          |               | 24A                       | C2             |                          | 29A                       | C1             |                          |
| EEPМ-4080D | 430       | 850 | 30 | 25 | 30 |     |    |            | 32        |                | 22400                          | 202kg                          |               | 16A                       | C4             |                          | 27A                       | C2             |                          |
| EEPМ-5060D | 520       | 670 | 30 | 25 | 30 | M10 | 70 | 20         | 30        | 700            | 21000                          | 193kg                          | AC<br>220V    | 19A                       | C2             | AC<br>380V<br>↓<br>440V  | 17A                       | C2             |                          |
| EEPМ-5080D | 520       | 850 | 30 | 25 | 30 |     |    |            | 40        |                | 28000                          | 244kg                          |               | 13A                       | C4             |                          | 22A                       | C2             |                          |
| EEPМ-6060D | 660       | 670 | 30 | 25 | 30 |     |    |            | 36        |                | 25200                          | 245kg                          |               | 15A                       | C4             |                          | 25A                       | C2             |                          |
| EEPМ-6080D | 660       | 850 | 30 | 25 | 30 |     |    |            | 48        |                | 33600                          | 310kg                          |               | 24A                       | C4             |                          | 29A                       | C2             |                          |
| EEPМ-8080D | 840       | 850 | 30 | 25 | 30 |     |    |            | 64        |                | 44800                          | 395kg                          |               | 32A                       | C8             |                          | 27A                       | C4             |                          |

Custom-made is available.

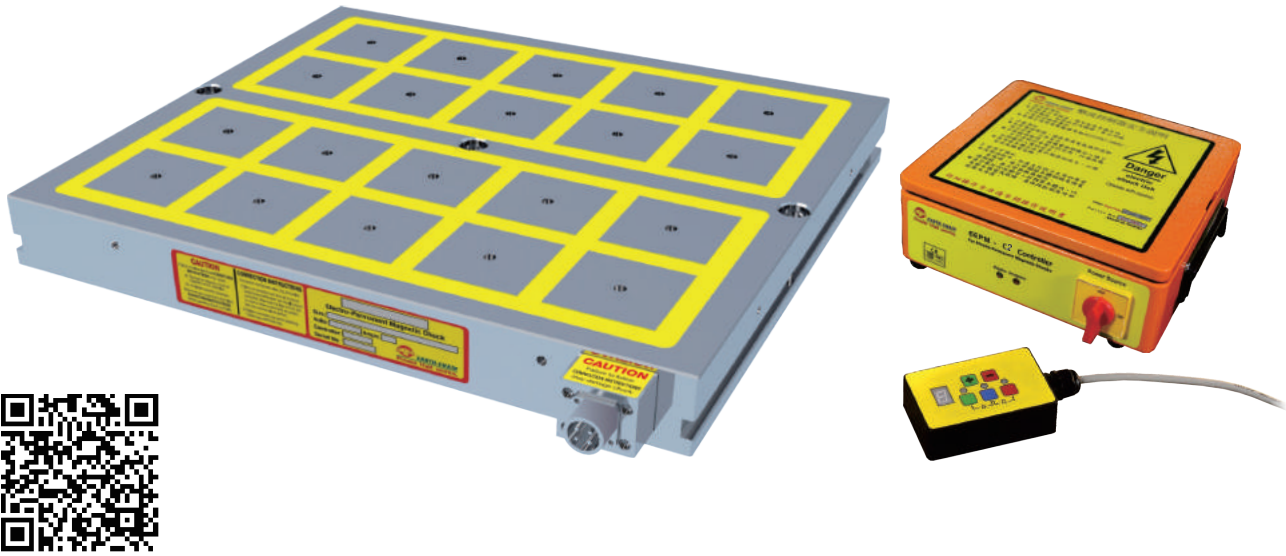
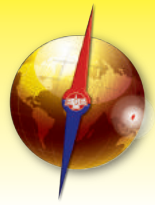

Pole 92X92 mm, Flux Line 50 mm, Magnetic Force 4800±5% kgf/4 Poles

**Applications:**

1. Suitable for large and high-thickness workpiece
2. Minimum size of workpiece required as 4 alternate magnetic square poles and above contacts is necessary for optimum clamping.
3. More functions for cooperate with Induction Block and Spring Block. (See the detail of Option Accessories)

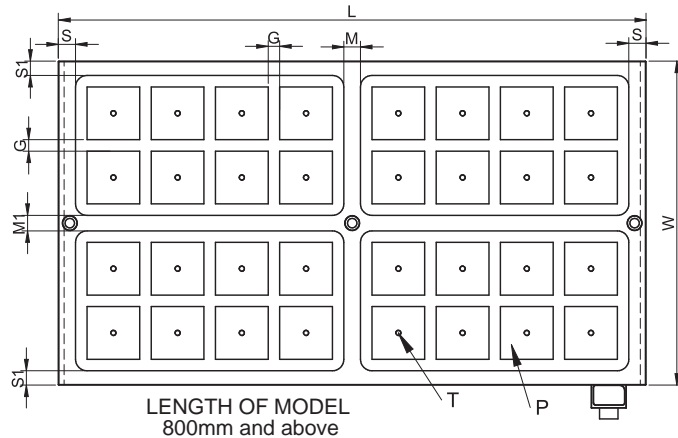
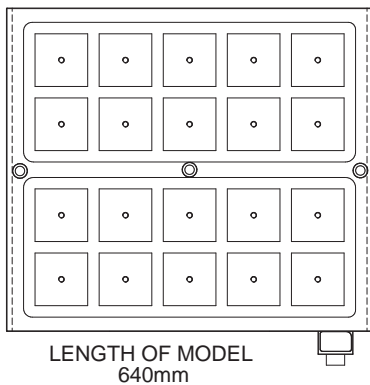

Unit:mm

| MODEL NO.   | DIMENSION |      |    |    |    |    |     |    | PITCH G | POLE P | NO. OF POLE | Unipolar suction kgf ±5% | TOTAL HOLDING POWER kgf ±5% | CHUCK N.W. | VOLTAGE (Single Phase) | CURRENT AMP | CONTROLLER (included) |
|-------------|-----------|------|----|----|----|----|-----|----|---------|--------|-------------|--------------------------|-----------------------------|------------|------------------------|-------------|-----------------------|
|             | W         | L    | S  | S1 | M  | M1 | T   | H  |         |        |             |                          |                             |            |                        |             |                       |
| EEPM-6060E  | 565       | 640  | 30 | 25 | -- | 27 |     |    |         | 20     | 24000       | 214kg                    | AC 380V<br>~<br>440V        | 24A        | C2                     |             |                       |
| EEPM-60100E | 565       | 1025 | 30 | 25 | 29 | 27 |     |    | 32      | 38400  | 343kg       | 13A                      |                             | C4         |                        |             |                       |
| EEPM-60120E | 565       | 1250 | 30 | 25 | 30 | 27 |     |    | 40      | 48000  | 418kg       | 24A                      |                             | C4         |                        |             |                       |
| EEPM-8080E  | 790       | 800  | 30 | 25 | 28 | 28 | M10 | 70 | 36      | 43200  | 374kg       | 26A                      |                             | C4         |                        |             |                       |
| EEPM-80100E | 790       | 1025 | 30 | 25 | 29 | 28 |     |    | 48      | 57600  | 480kg       | 19A                      |                             | C4         |                        |             |                       |
| EEPM-80120E | 790       | 1250 | 30 | 25 | 30 | 28 |     |    | 60      | 72000  | 585kg       | 15A                      |                             | C8         |                        |             |                       |

Custom-made is available.

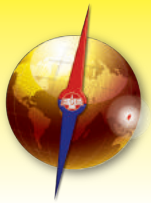

# Mag Vise

## Magnetic Workholding

### Option Controller EEPM-C Serie

■ Option controller available for control multi-EEPM chuck



Controller

#### Features:

1. SCR1600 volts/ 70 amps more safety and durability.
2. Built-in transformer 220V~480V full voltage is applicable.
3. Intelligent Precision IC Chip Modification Program.
4. Communication Modbus connection function, can be automated with CNC machine and robot arm.
5. Clock rate up to 20Mhz (generally 8 Mhz), sensitive and increased operation reliability.

#### Magnetism level:

The magnetism is designed with an adjustable function and divided into 8 levels to meet with the client requirements in sizes and applications.

Relative magnetic force strength percentage table

| Magnetism level | 1  | 2  | 3  | 4  | 5  | 6  | 7  | 8   |
|-----------------|----|----|----|----|----|----|----|-----|
| %               | 16 | 28 | 40 | 52 | 64 | 76 | 88 | 100 |



- a. The maximum magnetic force of cubic pole 50mm square can reach up to  $1,250 \pm 5\%$  kgf/100cm<sup>2</sup> (4 poles).
- b. Level 8 represents maximum magnetic force.

Signal line can be connected with the machine and the robot arm





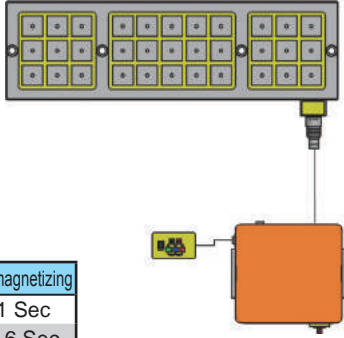
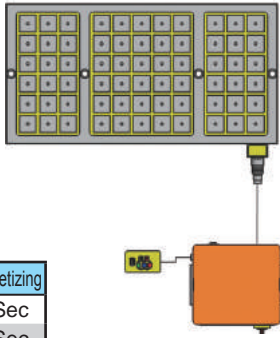
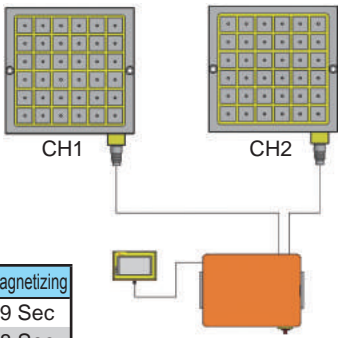
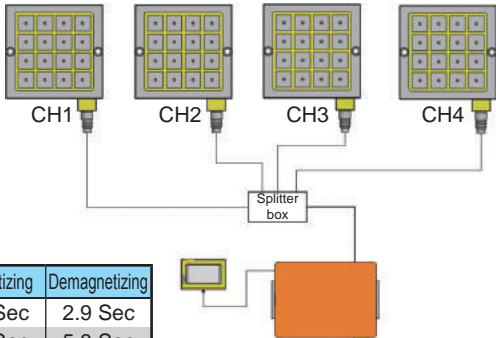
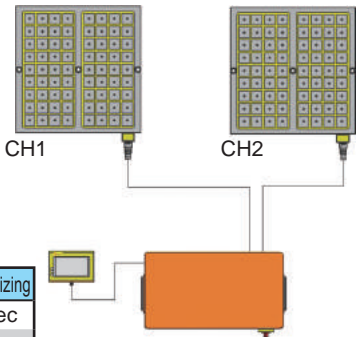
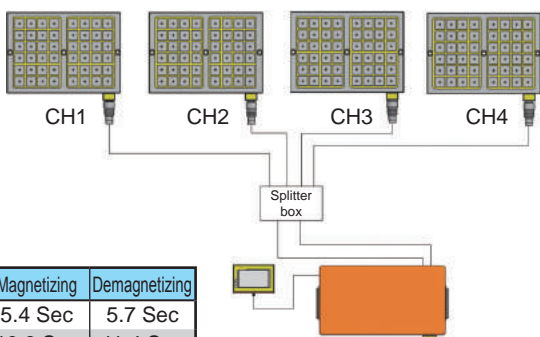
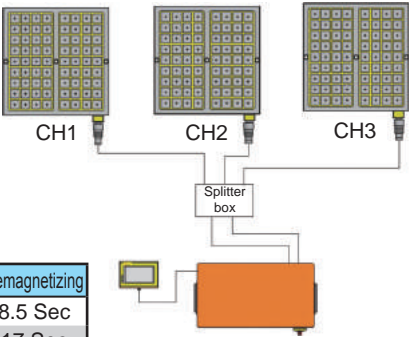
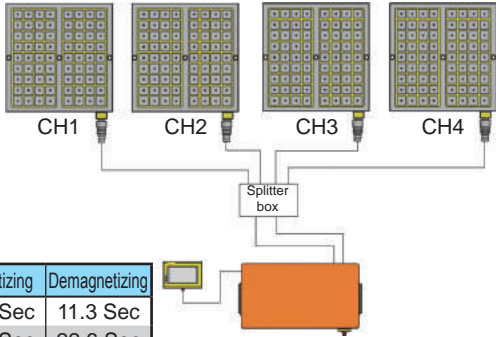

Please advice the voltage of EEPM chucks are AC220V or AC380V~AC440V when purchased. (Depending on the controller specification the junction box is option product.)

|  <table border="1"> <thead> <tr> <th>Voltage</th> <th>Magnetizing</th> <th>Demagnetizing</th> </tr> </thead> <tbody> <tr> <td>220V</td> <td>1 Sec</td> <td>1 Sec</td> </tr> <tr> <td>380V~440V</td> <td>1.5 Sec</td> <td>1.6 Sec</td> </tr> </tbody> </table>         | Voltage                                     | Magnetizing   | Demagnetizing | 220V | 1 Sec   | 1 Sec   | 380V~440V | 1.5 Sec  | 1.6 Sec  |  <table border="1"> <thead> <tr> <th>Voltage</th> <th>Magnetizing</th> <th>Demagnetizing</th> </tr> </thead> <tbody> <tr> <td>220V</td> <td>1.4 Sec</td> <td>1.5 Sec</td> </tr> <tr> <td>380V~440V</td> <td>2.9 Sec</td> <td>3.0 Sec</td> </tr> </tbody> </table>      | Voltage | Magnetizing | Demagnetizing | 220V | 1.4 Sec  | 1.5 Sec  | 380V~440V | 2.9 Sec  | 3.0 Sec  |
|--|---|---------------|---------------|------|---------|---------|-----------|----------|----------|---|---------|-------------|---------------|------|----------|----------|-----------|----------|----------|
| Voltage  | Magnetizing                                 | Demagnetizing |               |      |         |         |           |          |          |   |         |             |               |      |          |          |           |          |          |
| 220V   | 1 Sec                                       | 1 Sec         |               |      |         |         |           |          |          |   |         |             |               |      |          |          |           |          |          |
| 380V~440V  | 1.5 Sec                                     | 1.6 Sec       |               |      |         |         |           |          |          |   |         |             |               |      |          |          |           |          |          |
| Voltage  | Magnetizing                                 | Demagnetizing |               |      |         |         |           |          |          |   |         |             |               |      |          |          |           |          |          |
| 220V   | 1.4 Sec                                     | 1.5 Sec       |               |      |         |         |           |          |          |   |         |             |               |      |          |          |           |          |          |
| 380V~440V  | 2.9 Sec                                     | 3.0 Sec       |               |      |         |         |           |          |          |   |         |             |               |      |          |          |           |          |          |
| Control for 1 to 1 pieces of C1 EEPM chucks  | Control for 1 to 1 pieces of C2 EEPM chucks |               |               |      |         |         |           |          |          |   |         |             |               |      |          |          |           |          |          |
|  <table border="1"> <thead> <tr> <th>Voltage</th> <th>Magnetizing</th> <th>Demagnetizing</th> </tr> </thead> <tbody> <tr> <td>220V</td> <td>2.8 Sec</td> <td>2.9 Sec</td> </tr> <tr> <td>380V~440V</td> <td>5.5 Sec</td> <td>5.8 Sec</td> </tr> </tbody> </table>    | Voltage                                     | Magnetizing   | Demagnetizing | 220V | 2.8 Sec | 2.9 Sec | 380V~440V | 5.5 Sec  | 5.8 Sec  |  <table border="1"> <thead> <tr> <th>Voltage</th> <th>Magnetizing</th> <th>Demagnetizing</th> </tr> </thead> <tbody> <tr> <td>220V</td> <td>2.8 Sec</td> <td>2.9 Sec</td> </tr> <tr> <td>380V~440V</td> <td>5.5 Sec</td> <td>5.8 Sec</td> </tr> </tbody> </table>      | Voltage | Magnetizing | Demagnetizing | 220V | 2.8 Sec  | 2.9 Sec  | 380V~440V | 5.5 Sec  | 5.8 Sec  |
| Voltage  | Magnetizing                                 | Demagnetizing |               |      |         |         |           |          |          |   |         |             |               |      |          |          |           |          |          |
| 220V   | 2.8 Sec                                     | 2.9 Sec       |               |      |         |         |           |          |          |   |         |             |               |      |          |          |           |          |          |
| 380V~440V  | 5.5 Sec                                     | 5.8 Sec       |               |      |         |         |           |          |          |   |         |             |               |      |          |          |           |          |          |
| Voltage  | Magnetizing                                 | Demagnetizing |               |      |         |         |           |          |          |   |         |             |               |      |          |          |           |          |          |
| 220V   | 2.8 Sec                                     | 2.9 Sec       |               |      |         |         |           |          |          |   |         |             |               |      |          |          |           |          |          |
| 380V~440V  | 5.5 Sec                                     | 5.8 Sec       |               |      |         |         |           |          |          |   |         |             |               |      |          |          |           |          |          |
| Control for 1 to 2 pieces of C2 EEPM chucks  | Control for 1 to 4 pieces of C1 EEPM chucks |               |               |      |         |         |           |          |          |   |         |             |               |      |          |          |           |          |          |
|  <table border="1"> <thead> <tr> <th>Voltage</th> <th>Magnetizing</th> <th>Demagnetizing</th> </tr> </thead> <tbody> <tr> <td>220V</td> <td>5.4 Sec</td> <td>5.7 Sec</td> </tr> <tr> <td>380V~440V</td> <td>10.9 Sec</td> <td>11.4 Sec</td> </tr> </tbody> </table> | Voltage                                     | Magnetizing   | Demagnetizing | 220V | 5.4 Sec | 5.7 Sec | 380V~440V | 10.9 Sec | 11.4 Sec |  <table border="1"> <thead> <tr> <th>Voltage</th> <th>Magnetizing</th> <th>Demagnetizing</th> </tr> </thead> <tbody> <tr> <td>220V</td> <td>5.4 Sec</td> <td>5.7 Sec</td> </tr> <tr> <td>380V~440V</td> <td>10.9 Sec</td> <td>11.4 Sec</td> </tr> </tbody> </table>   | Voltage | Magnetizing | Demagnetizing | 220V | 5.4 Sec  | 5.7 Sec  | 380V~440V | 10.9 Sec | 11.4 Sec |
| Voltage  | Magnetizing                                 | Demagnetizing |               |      |         |         |           |          |          |   |         |             |               |      |          |          |           |          |          |
| 220V   | 5.4 Sec                                     | 5.7 Sec       |               |      |         |         |           |          |          |   |         |             |               |      |          |          |           |          |          |
| 380V~440V  | 10.9 Sec                                    | 11.4 Sec      |               |      |         |         |           |          |          |   |         |             |               |      |          |          |           |          |          |
| Voltage  | Magnetizing                                 | Demagnetizing |               |      |         |         |           |          |          |   |         |             |               |      |          |          |           |          |          |
| 220V   | 5.4 Sec                                     | 5.7 Sec       |               |      |         |         |           |          |          |   |         |             |               |      |          |          |           |          |          |
| 380V~440V  | 10.9 Sec                                    | 11.4 Sec      |               |      |         |         |           |          |          |   |         |             |               |      |          |          |           |          |          |
| Control for 1 to 2 pieces of C4 EEPM chucks  | Control for 1 to 4 pieces of C2 EEPM chucks |               |               |      |         |         |           |          |          |   |         |             |               |      |          |          |           |          |          |
|  <table border="1"> <thead> <tr> <th>Voltage</th> <th>Magnetizing</th> <th>Demagnetizing</th> </tr> </thead> <tbody> <tr> <td>220V</td> <td>8.1 Sec</td> <td>8.5 Sec</td> </tr> <tr> <td>380V~440V</td> <td>16.2 Sec</td> <td>17 Sec</td> </tr> </tbody> </table>   | Voltage                                     | Magnetizing   | Demagnetizing | 220V | 8.1 Sec | 8.5 Sec | 380V~440V | 16.2 Sec | 17 Sec   |  <table border="1"> <thead> <tr> <th>Voltage</th> <th>Magnetizing</th> <th>Demagnetizing</th> </tr> </thead> <tbody> <tr> <td>220V</td> <td>10.8 Sec</td> <td>11.3 Sec</td> </tr> <tr> <td>380V~440V</td> <td>21.5 Sec</td> <td>22.6 Sec</td> </tr> </tbody> </table> | Voltage | Magnetizing | Demagnetizing | 220V | 10.8 Sec | 11.3 Sec | 380V~440V | 21.5 Sec | 22.6 Sec |
| Voltage  | Magnetizing                                 | Demagnetizing |               |      |         |         |           |          |          |   |         |             |               |      |          |          |           |          |          |
| 220V   | 8.1 Sec                                     | 8.5 Sec       |               |      |         |         |           |          |          |   |         |             |               |      |          |          |           |          |          |
| 380V~440V  | 16.2 Sec                                    | 17 Sec        |               |      |         |         |           |          |          |   |         |             |               |      |          |          |           |          |          |
| Voltage  | Magnetizing                                 | Demagnetizing |               |      |         |         |           |          |          |   |         |             |               |      |          |          |           |          |          |
| 220V   | 10.8 Sec                                    | 11.3 Sec      |               |      |         |         |           |          |          |   |         |             |               |      |          |          |           |          |          |
| 380V~440V  | 21.5 Sec                                    | 22.6 Sec      |               |      |         |         |           |          |          |   |         |             |               |      |          |          |           |          |          |
| Control for 1 to 3 pieces of C4 EEPM chucks  | Control for 1 to 4 pieces of C4 EEPM chucks |               |               |      |         |         |           |          |          |   |         |             |               |      |          |          |           |          |          |

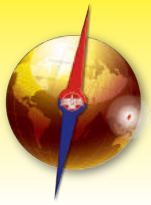

# Mag Vise

## Human Machine Interface controller EEPM-HMI Series

### Magnetic Workholding

■ Suitable for use on EEPM Series of Electro-Permanent Magnetic Chuck.



Controller

EEP-M-HMI

### Features:

- 1.HMI touch screen - can be set the screen brightness, key sound, language...etc.
- 2.Display the abnormal status, such as the chuck cable unconnected, and instruction the troubleshooting.
3. Can detect low voltage abnormal situation, to avoid the insufficient magnetic force situation.

### Example description:

Develop Human Machine Interface touch screen system, feedback operation status from screen page, and the devices could be drive by pre-set program and parameter.

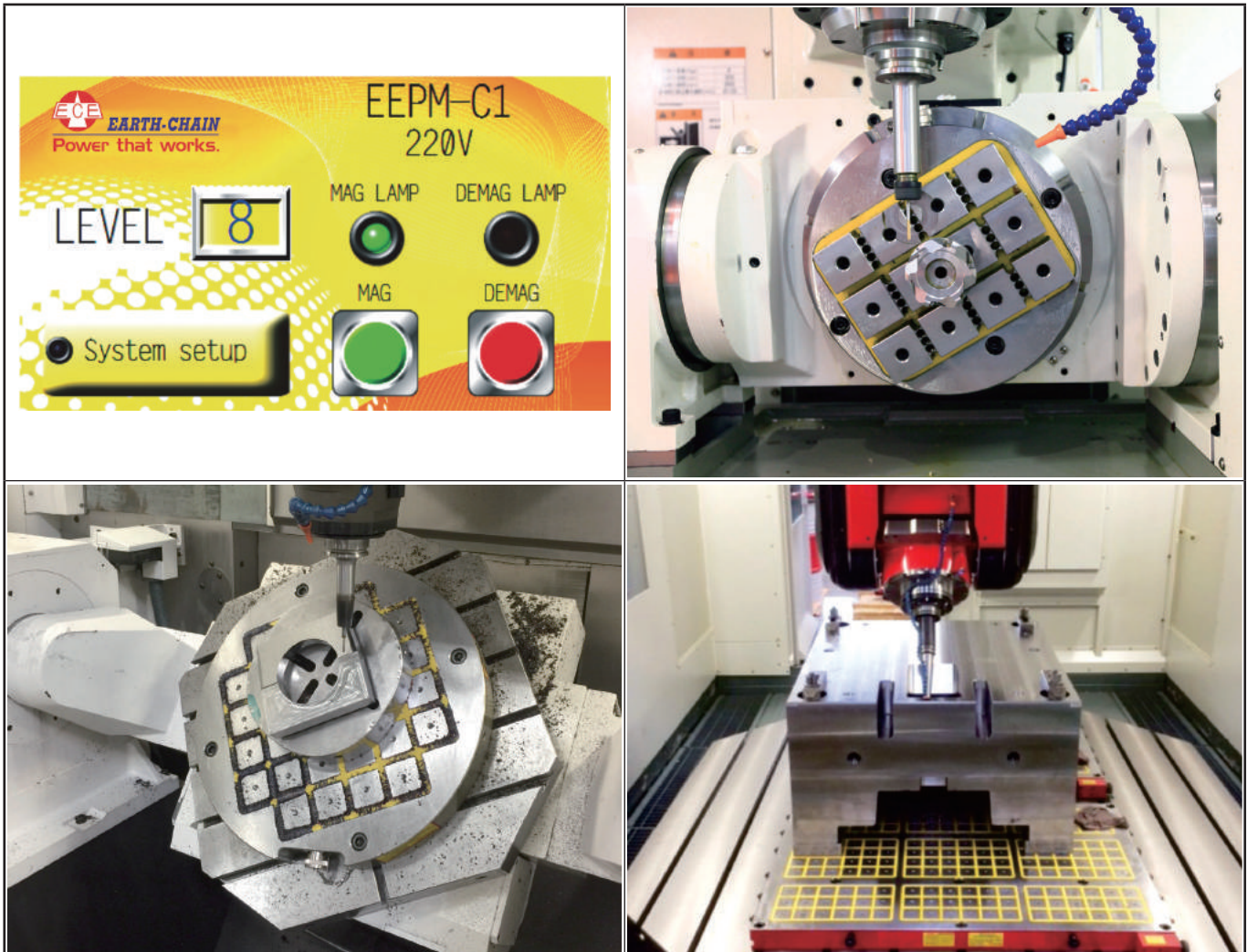

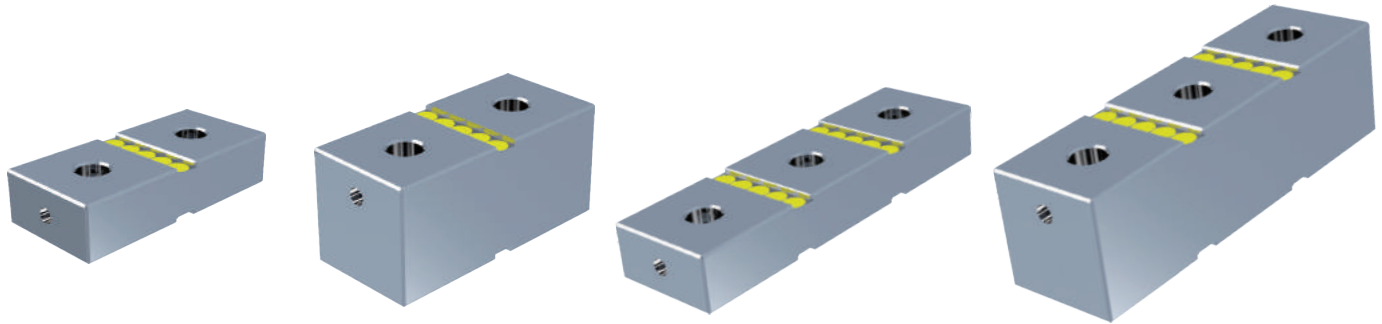

**Features:**

1. Induction Block EEPM-IB series are use with EEPM chucks, can be increased to more functions on workholding.
2. Increased using life of magnetic chuck: We suggest always use induction block to clamp workpieces, due to workpiece will not touch to the surface of chucks it can be keep chucks always be new.
3. Convenience and Accuracy: Induction Block are interchanging & consuming accessories, you can machining surface or forming induction blocks for the workpiece required by the machine directly, so the parallelism of induction block will always 100% match to the machine.

■ EEPM-IBA Suitable for use on EEPM-A Series Chucks.

Unit:mm

| MODEL NO.  | NO. OF POLE | W  | L   | HEIGHT | P  | G |
|------------|-------------|----|-----|--------|----|---|
| EEP-IB215A | 2           | 35 | 77  | 15     | 35 | 7 |
| EEP-IB315A | 3           | 35 | 119 | 15     | 35 | 7 |

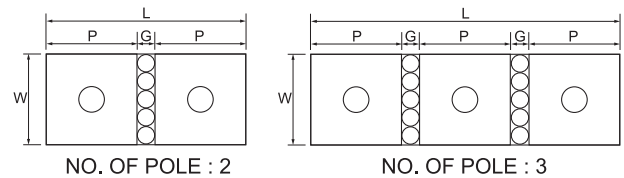

■ EEPM-IBB Suitable for use on EEPM-B Series Chucks.

Unit:mm

| MODEL NO.  | NO. OF POLE | W  | L   | HEIGHT | P  | G  |
|------------|-------------|----|-----|--------|----|----|
| EEP-IB225B | 2           | 50 | 110 | 25     | 50 | 10 |
| EEP-IB325B | 3           | 50 | 170 | 25     | 50 | 10 |
| MODEL NO.  | NO. OF POLE | W  | L   | HEIGHT | P  | G  |
| EEP-IB250B | 2           | 50 | 110 | 50     | 50 | 10 |
| EEP-IB350B | 3           | 50 | 170 | 50     | 50 | 10 |

Relative magnetic force to height of EEPM-IB :

| MODEL NO.  | Height | Holding Power (Kgf) |
|------------|--------|---------------------|
| EEP-IB215A | 15 mm  | 80 %                |
| EEP-IB315A | 15 mm  | 64 %                |

| MODEL NO.  | Height | Holding Power (Kgf) |
|------------|--------|---------------------|
| EEP-IB225B | 25 mm  | 82 %                |
| EEP-IB325B | 25 mm  | 68 %                |

| MODEL NO.  | Height | Holding Power (Kgf) |
|------------|--------|---------------------|
| EEP-IB250B | 50 mm  | 72 %                |
| EEP-IB350B | 50 mm  | 58 %                |

\*50mm height induction block with lower holding power that suitable for stopping block only.

■ EEPM-IBD Suitable for use on EEPM-D Series Chucks.

Unit:mm

| MODEL NO.  | NO. OF POLE | W  | L   | HEIGHT | P  | G  |
|------------|-------------|----|-----|--------|----|----|
| EEP-IB225D | 2           | 70 | 160 | 25     | 70 | 20 |
| EEP-IB325D | 3           | 70 | 250 | 25     | 70 | 20 |

| MODEL NO.  | Height | Holding Power (Kgf) |
|------------|--------|---------------------|
| EEP-IB225D | 25 mm  | 86 %                |
| EEP-IB325D | 25 mm  | 70 %                |

■ EEPM-IBE Suitable for use on EEPM-E Series Chucks.

Unit:mm

| MODEL NO.  | NO. OF POLE | W  | L   | HEIGHT | P  | G  |
|------------|-------------|----|-----|--------|----|----|
| EEP-IB225E | 2           | 92 | 204 | 25     | 92 | 20 |
| EEP-IB325E | 3           | 92 | 316 | 25     | 92 | 20 |

| MODEL NO.  | Height | Holding Power (Kgf) |
|------------|--------|---------------------|
| EEP-IB225E | 25 mm  | 86 %                |
| EEP-IB325E | 25 mm  | 70 %                |

Example:

| EEP-IB2560B | Induction Block | Total Holding Power      |
|-------------|-----------------|--------------------------|
| EEP-IB2560B | None            | 7,500±5% kgf             |
| EEP-IB2560B | IB225B x 24pcs  | 6,150±5% kgf (7,500x82%) |



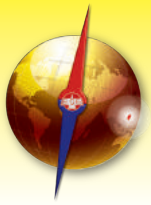

### Working Example

|  |  |  |
|--|--|--|
|  |  |  |
| <p>Directly processing the grooves on induction block and placing the bars in demand for multi-workpiece on 5 sides machining.</p> | <p>Machining slots and steps on IB for positioning multi-workpiece on 5 sides machining.</p> | <p>Used 25mm &amp; 50mm height of IB for positioning multi-workpiece on surface machining.</p> |

|  |  |  |
|--|--|--|
|  |  |  |
| <p>Using height 25mm induction block for irregular workpiece on 5 sides machining.</p> |  |  |

|  |  |  |
|--|--|--|
|  |  |  |
| <p>Using height 25mm Induction block for multi-workpiece on 5 sides machining.</p> |  |  |

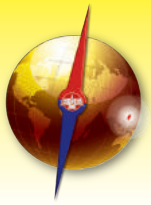

**Option Accessories**

**Induction Block EEPM-IBT Series**

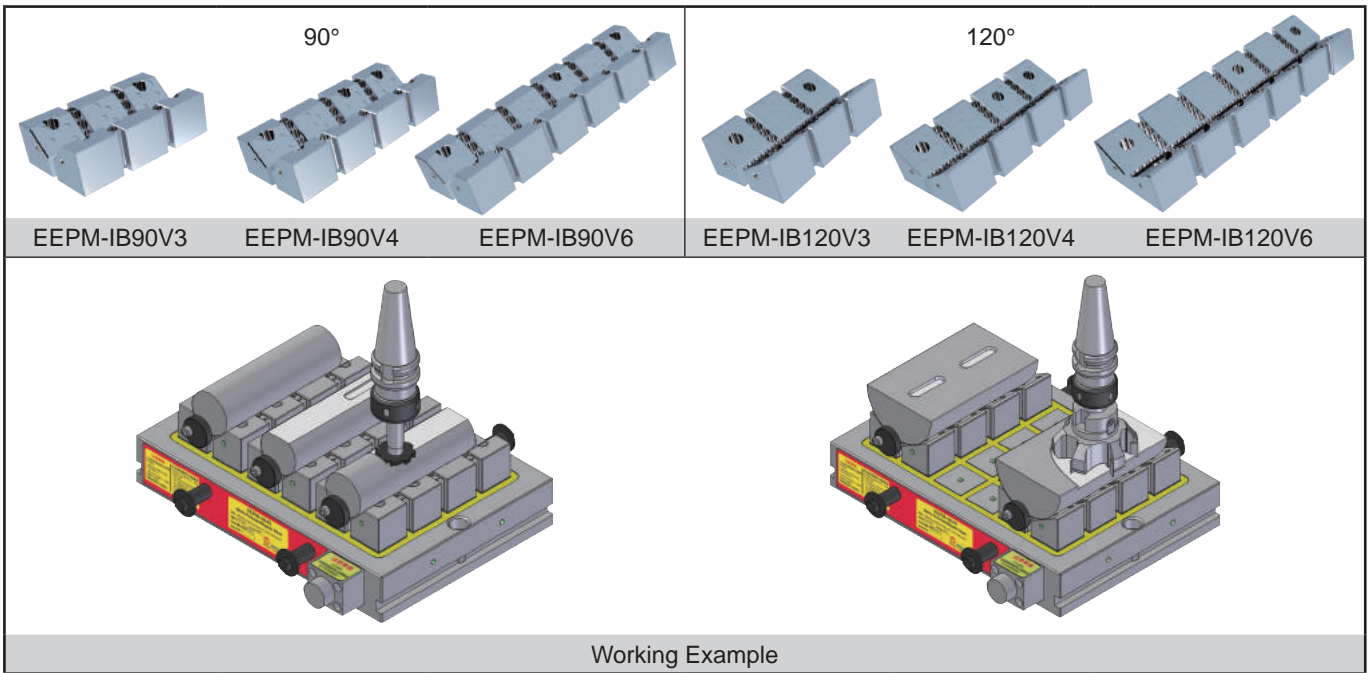
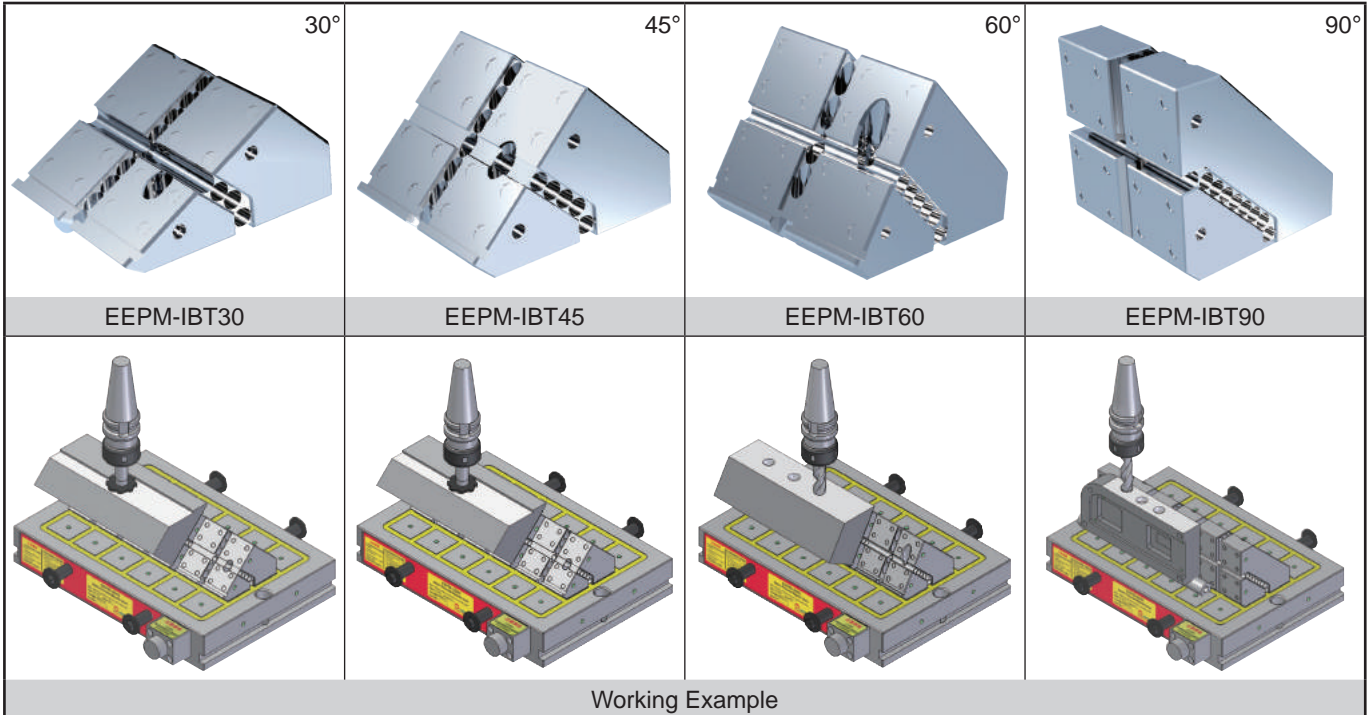

**Stopping Plate EEPM-PS40**

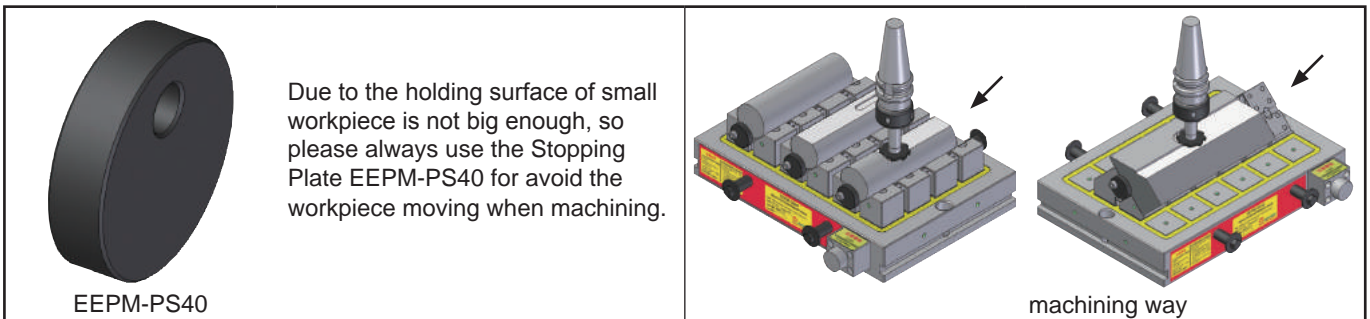



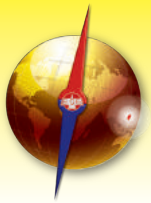

# Mag Vise

## Option Accessories

**Magnetic Workholding** ■ Suitable for use on EEPM Series of Electro-Permanent Magnetic Chuck.

### Spring Block EEPM-SP Series

■ Suitable for clamping on iron cast, irregular form and flexuous workpieces, it will not be out of shape the workpiece after machining. **Features:**

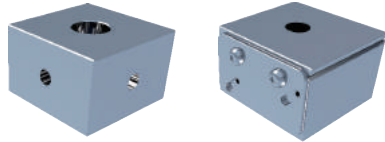

Fixed Block EEPM-SPF Series      Spring Block EEPM-SP Series

1. Suitable for clamping on iron cast, irregular form and flexuous workpieces, it will not be out of shape of the workpiece after machining.
2. 3 Fixed Blocks is necessary for each workpiece clamping, it could be makes a basic surface for the workpiece touch to the Spring Blocks.
3. Elasticity of EEPM-SP35: Each 2.0 mm for up and down.
4. Elasticity of EEPM-SP & EEPM-SP70: Each 2.5 mm for up and down.

Relative magnetic force to Fixed block and Spring block:

| MODEL NO.    | Holding Power (Kgf) |
|--------------|---------------------|
| Fixed Block  | 85 %                |
| Spring Block | 40 %                |

| MODEL NO.  | L  | W    | H  | SUITABLE      |
|------------|----|------|----|---------------|
| EEPM-SP35  | 35 | 33.6 | 21 | EEPM-A Series |
| EEPM-SPF35 | 35 | 35   | 23 |               |

| MODEL NO. | L  | W  | H    | SUITABLE      |
|-----------|----|----|------|---------------|
| EEPM-SP   | 48 | 48 | 30   | EEPM-B Series |
| EEPM-SPF  | 50 | 50 | 32.5 |               |

| MODEL NO.  | L  | W  | H    | SUITABLE      |
|------------|----|----|------|---------------|
| EEPM-SP70  | 68 | 68 | 30   | EEPM-D Series |
| EEPM-SPF70 | 70 | 70 | 32.5 |               |

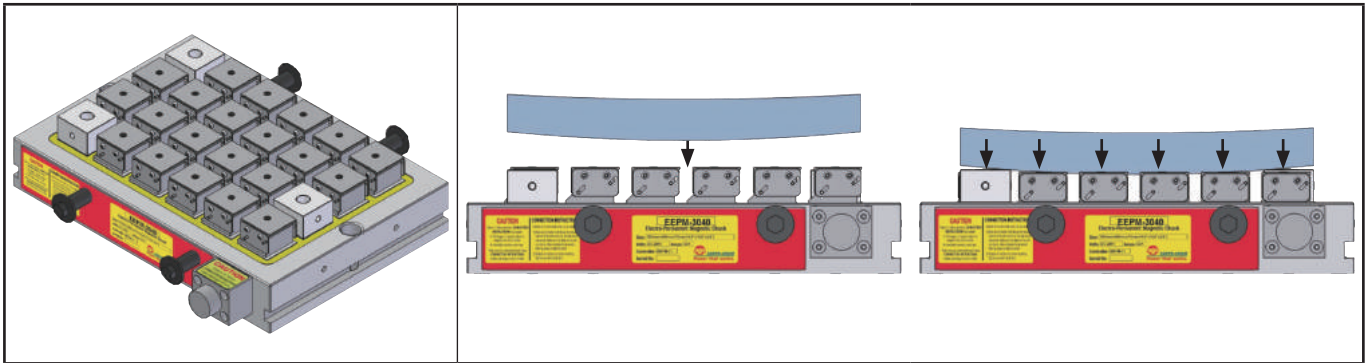

### Induction Sub Plate EEPM-ISP Series

■ Suitable for quantity of irregular and smaller workpiece. It can be machining multi-workpiece at same time easily.

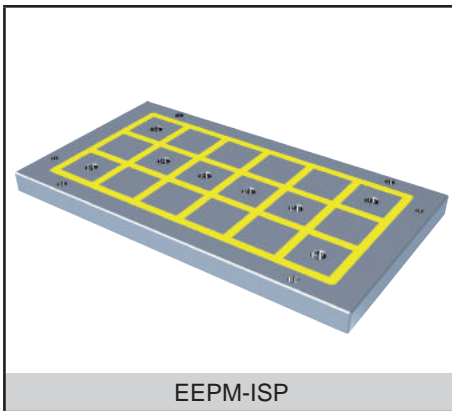

**Features:**

1. Suitable for quantity of irregular and smaller workpiece. It can be machining multi-workpiece at same time easily.
2. One EEPM chuck can be use several Induction Sub Plate exchangeability for machining different kind of workpiece.
3. Operation: Set up the Induction Sub Plates to the EEPM chucks first, then machining forms (Around 1-2mm depth) on ISP to match the workpiece by the machine directly. Start to clamp workpieces for machining.
4. Please advise the model No. of EEPM chuck which you want to combine for, when purchased.

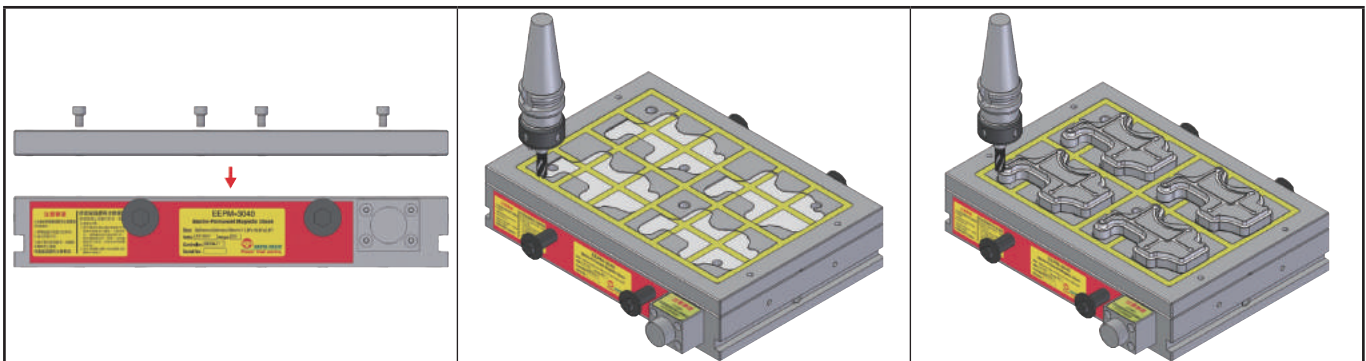





**Option Accessories**

**Induction block with raise pin structure EEPM-S50T**

■ Suitable for high-carbon steel workpiece

**Features:**

1. Since the high-carbon materials, the workpiece might be unable to be instantly released after machining cycle is completed due to residual magnetism.
2. The high-carbon steel parts are difficult to remove after the magnetization using induction block with raise pin structure can easily remove the workpiece.

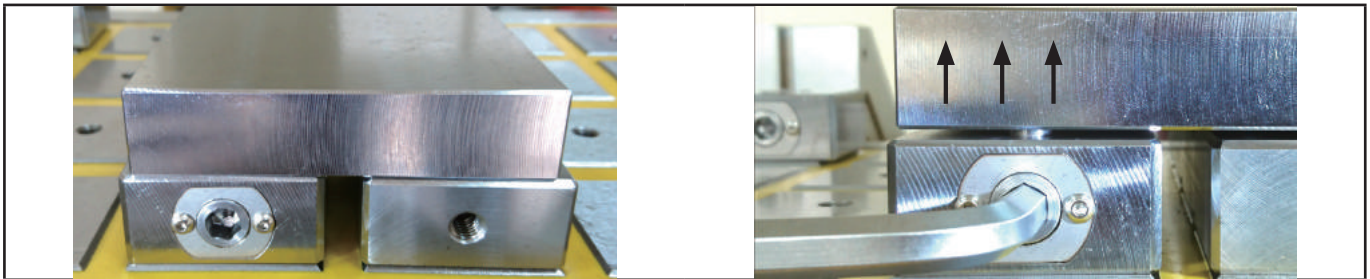
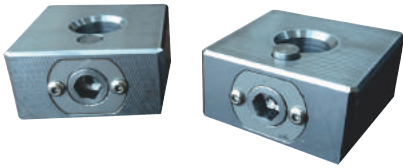

**Tap of Induction block screw hole EEPM-IBC50**

**Features:**

1. Put the EEPM-IBC50 into Induction block screw hole, to avoid the iron chip fall in the induction block screw holes when machining, can be save the time for chips clear.
2. Maximum temperature is 200 degrees, if without cooling device the surface of EEPM-IBC50 will be damage by high temperature of iron chips.

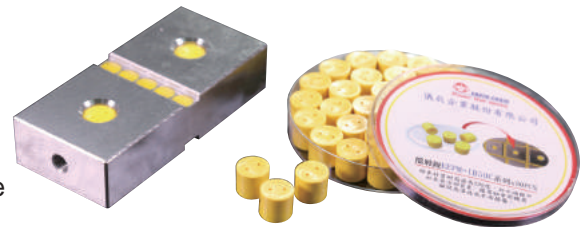

**Induction block guards: EEPM-IBS50**

**Features:**

1. Put the EEPM-IBS50 into Induction block gap, to avoid the iron chip fall in the induction block gaps when machining, can be save the time for clear.
2. Maximum temperature is 200 degrees, if without cooling device the surface of EEPM-IBS50 will be damage by high temperature of iron chips.

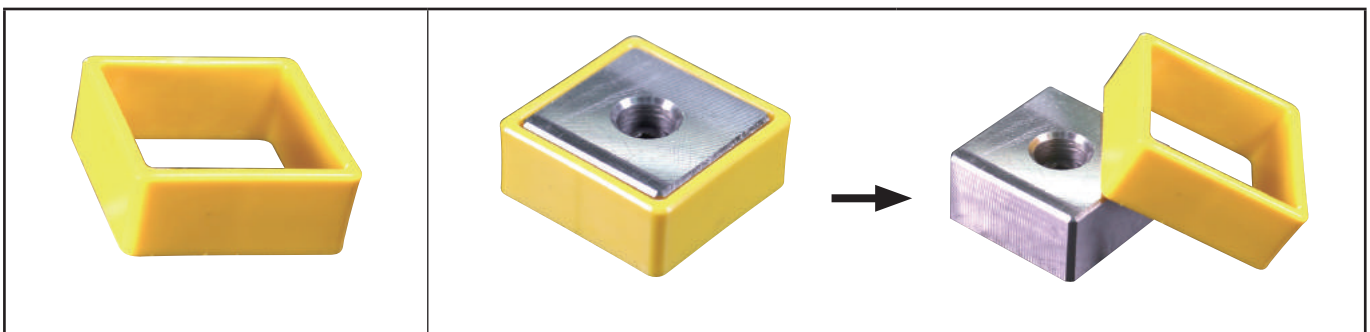

**Cover of Connector Base EEPM-CMS & EEPM-CMS1**

■ Effectively avoid short circuit cause by liquid or objects enter into the wires.

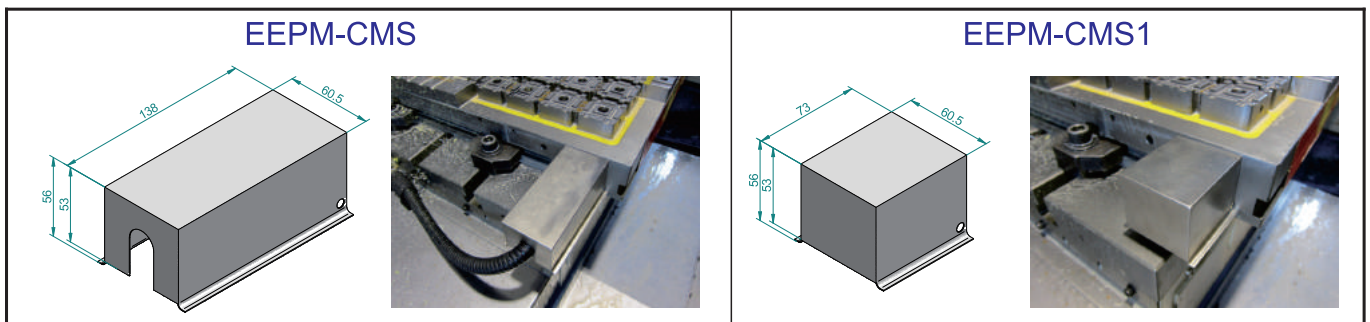



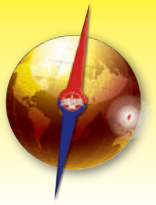

# Mag Vise

## Electro-Permanent Magnetic Chuck EPM Series

Magnetic Workholding

■ Suitable for CNC Vertical machining center (Can do 5 sides machining)

### Working Example

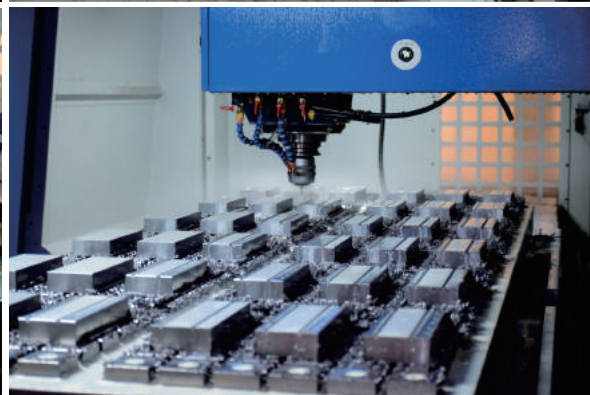
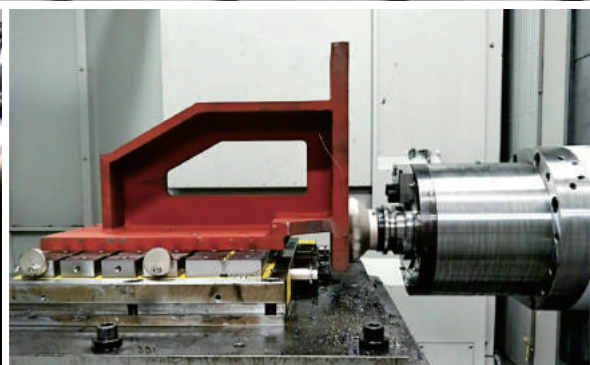
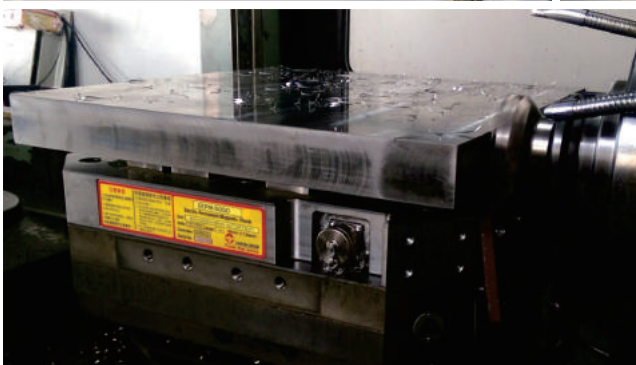
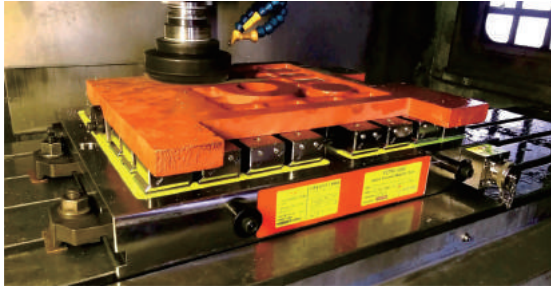



■ Suitable for all size of workpiece, can be use together with mechanical clamping tools.

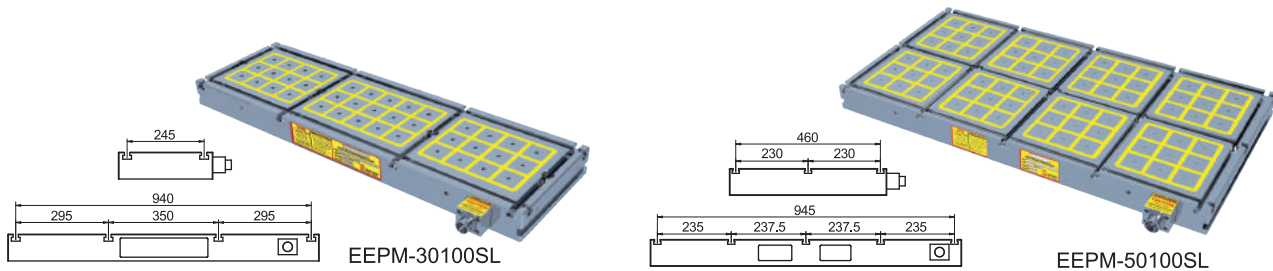

**Made with T-slots available**

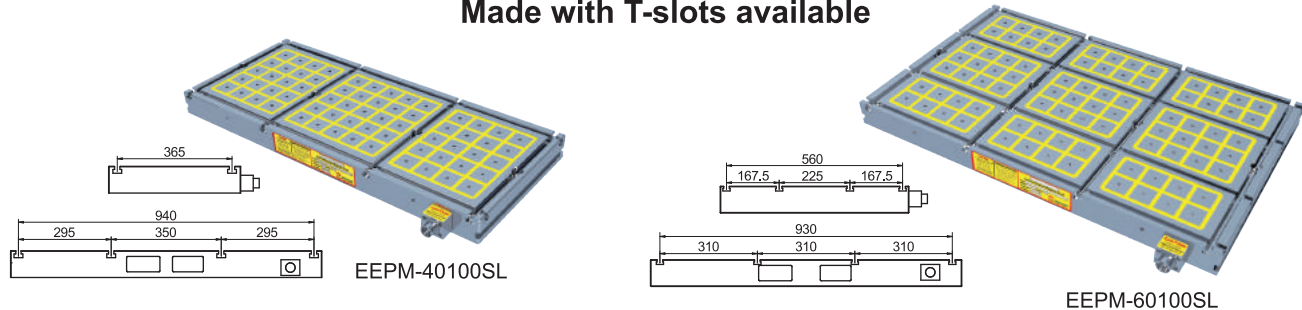

With multi-functions of machine table, clamping plate and magnetic chuck

Unit:mm

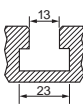
| MODEL NO.      | DIMENSION LxWxH | PITCH | POLE  | NO. OF POLE | T-SLOT  | TOTAL HOLDING POWER kgf ±5% | CHUCK N.W. | VOLTAGE (Single Phase) | CURRENT AMP | CONTROLLER (included) | VOLTAGE (Single Phase) | CURRENT AMP | CONTROLLER (included) |
|----------------|-----------------|-------|-------|-------------|---|-----------------------------|------------|------------------------|-------------|-----------------------|------------------------|-------------|-----------------------|
| EEPMSL-30100SL | 990x300x70      | 10    | 50x50 | 39          |  | 12100                       | 160kg      | AC 220V                | 24A         | C2                    | AC 380V<br>440V        | 16A         | C2                    |
| EEPMSL-40100SL | 990x420x70      | 10    | 50x50 | 65          |   | 20300                       | 225kg      |                        | 30A         | C2                    |                        | 13A         | C2                    |
| EEPMSL-50100SL | 990x500x70      | 10    | 50x50 | 72          |   | 22500                       | 260kg      |                        | 14A         | C4                    |                        | 14A         | C2                    |
| EEPMSL-60100SL | 990x600x70      | 10    | 50x50 | 84          |   | 26200                       | 320kg      |                        | 22A         | C4                    |                        | 9A          | C4                    |

Custom-made is available.

■ Suitable for big size of workpiece only, use together with mechanical clamping tool for heavy duty machining.

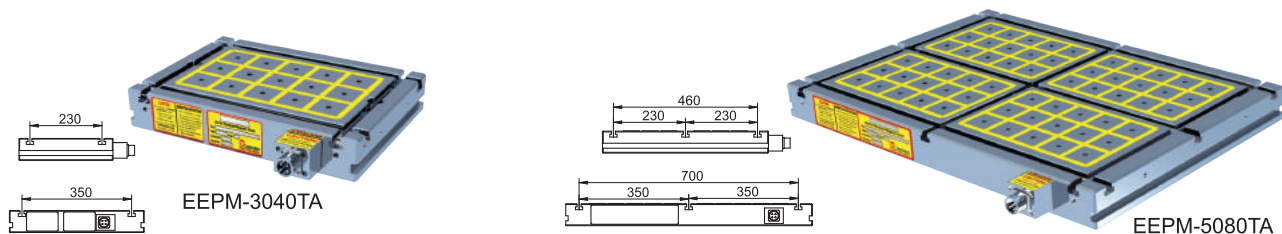

**Made with T-slots available**

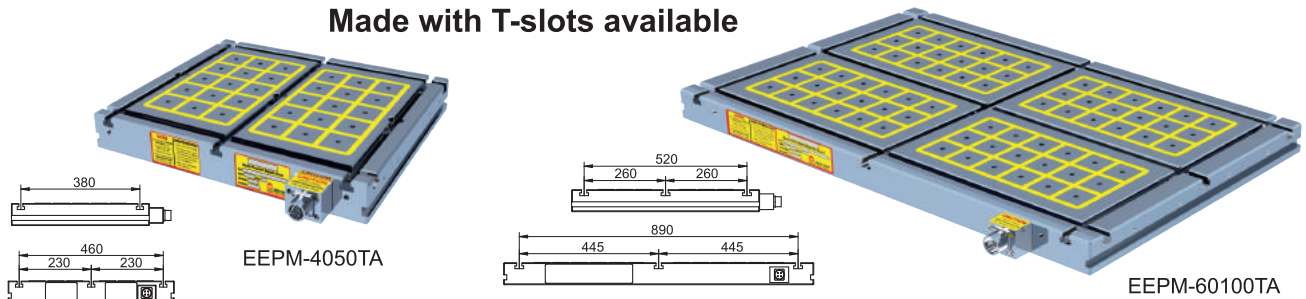

Lower price for big size of workpiece only.

Unit:mm

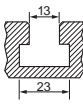
| MODEL NO.      | DIMENSION LxWxH | PITCH | POLE  | NO. OF POLE | T-SLOT  | TOTAL HOLDING POWER kgf ±5% | CHUCK N.W. | VOLTAGE (Single Phase) | CURRENT AMP | CONTROLLER (included) | VOLTAGE (Single Phase) | CURRENT AMP | CONTROLLER (included) |
|----------------|-----------------|-------|-------|-------------|---|-----------------------------|------------|------------------------|-------------|-----------------------|------------------------|-------------|-----------------------|
| EEPMTA-3040TA  | 420x300x70      | 10    | 50x50 | 15          |  | 4600                        | 50kg       | AC 220V                | 17A         | C1                    | AC 380V<br>440V        | 14A         | C1                    |
| EEPMTA-4050TA  | 530x440x70      | 10    | 50x50 | 30          |   | 9300                        | 80kg       |                        | 33A         | C1                    |                        | 16A         | C1                    |
| EEPMTA-5080TA  | 790x530x70      | 10    | 50x50 | 60          |   | 18700                       | 180kg      |                        | 32A         | C2                    |                        | 14A         | C2                    |
| EEPMTA-60100TA | 990x600x70      | 10    | 50x50 | 72          |   | 22500                       | 240kg      |                        | 23A         | C4                    |                        | 13A         | C2                    |

Custom-made is available.



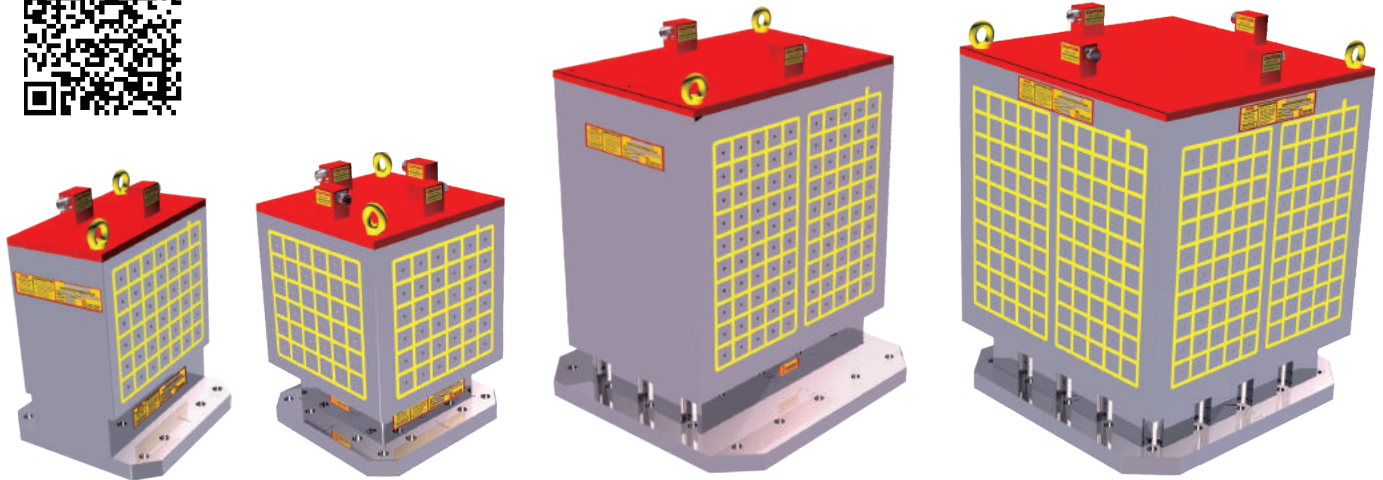

EEPM-500V2

EEPM-500V4

EEPM-800V2

EEPM-800V4

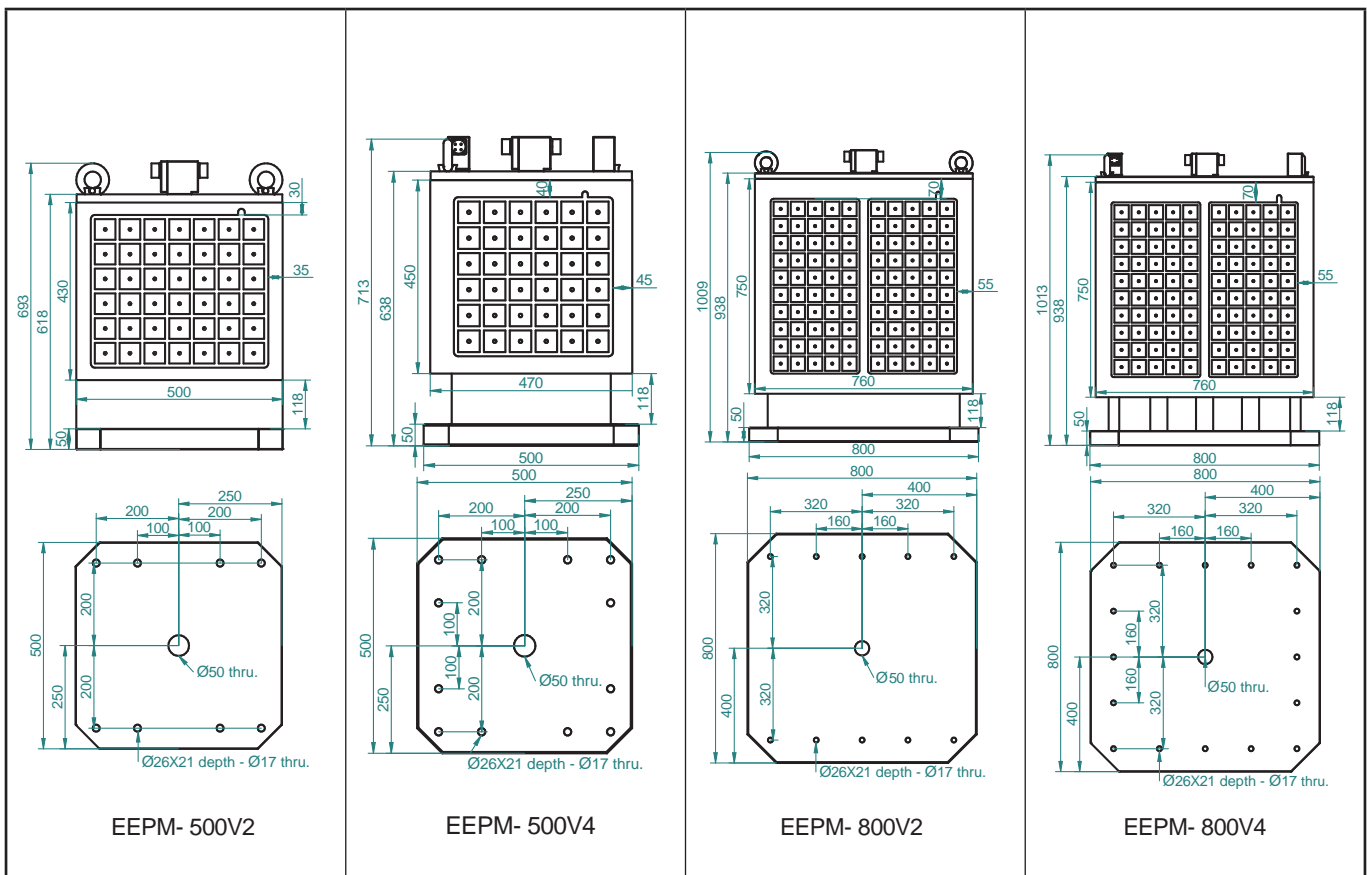

Unit:mm

| MODEL NO.  | DIMENSION | PITCH | POLE  | NO. OF POLE | TOTAL HOLDING POWER kgf ±5% | CHUCK N.W. | VOLTAGE (Single Phase) | CURRENT AMP | CONTROLLER (included) | VOLTAGE (Single Phase) | CURRENT AMP | CONTROLLER (included) |
|------------|-----------|-------|-------|-------------|-----------------------------|------------|------------------------|-------------|-----------------------|------------------------|-------------|-----------------------|
| EEPM-500V2 | 430×500   | 10    | 50×50 | 42×2        | 13100                       | 480kg      | AC 220V                | 30A         | C2                    | AC 380V                | 14A         | C2                    |
| EEPM-500V4 | 450×470   | 10    | 50×50 | 36×4        | 11200                       | 510kg      |                        | 20A         | C2                    |                        | 13A         | C1                    |
| EEPM-800V2 | 750×760   | 10    | 50×50 | 100×2       | 31200                       | 760kg      |                        | 22A         | C4                    | 440V                   | 10A         | C4                    |
| EEPM-800V4 | 750×760   | 10    | 50×50 | 100×4       | 31200                       | 810kg      |                        | 22A         | C4                    |                        | 10A         | C4                    |

Custom-made is available.



**Features:**

1. Super power magnetic force 1250kgf/100cm<sup>2</sup> ±5%. (4 Poles)
2. Control each working face for ON and OFF, so it can be load and unload the workpiece on each working face. 3~10 seconds control for power ON and OFF.
3. Each EEPM-V type can be clamp multi-workpiece machining, instead of multi-pallet exchange.
4. Can do 5 sides machining, un-obstructed movement of cutters during machining. One cycle to finish a workpiece, helps in achieving best machining accuracy and increases efficiency a lot.

**Applications:**

1. Suitable for CNC horizontal machining center.
2. EEPM-V2 with 2 working faces suitable for bigger workpiece.  
EEPm-V4 with 4 working faces suitable for medium workpiece.
3. More functions for cooperate with Induction Block and Spring Block. (See the detail of Option Accessories)

**Working Example**

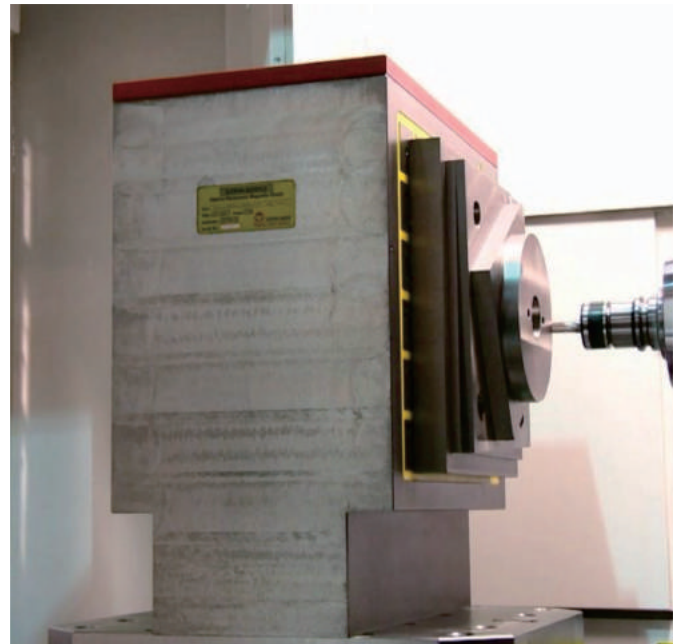
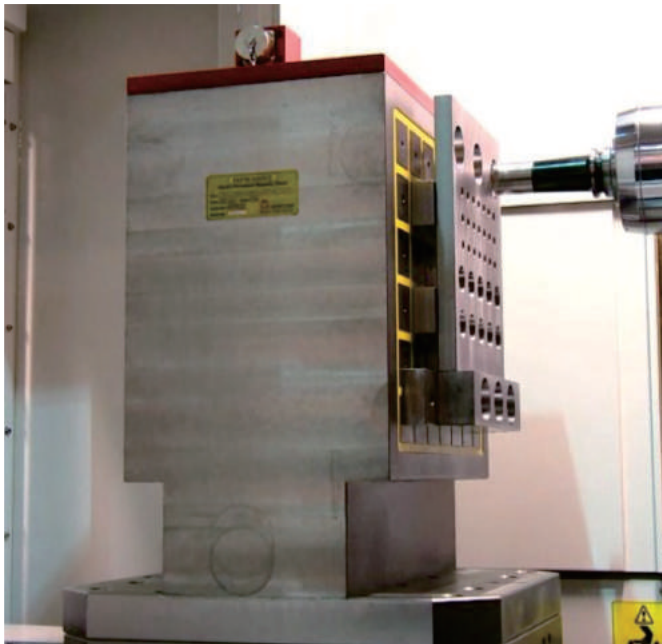

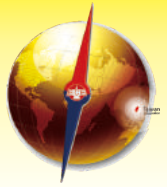

■ Suitable for horizontal milling & boring machine on precision machining of division.



Traditional Milling Machine can do 5 sides machining too.  
PATENT NO.350429

**Features:**

1. We changed traditional clamping way of Index Table. Made with Electro-Permanent Magnetic Chuck, can do 5 side machining, without any obstructed movement of cutters during machining.
2. Super magnetic force 1250kgf/100cm<sup>2</sup>±5%.
3. Structure of Electro-Permanent Magnetic Chuck, 3~10 seconds control for power ON & OFF. No electric power supply required to keep the chuck ON. So no electric cable disturbed, can be turning freely.
4. Magnetic power adjustable.
5. Pneumatic system to rotate and fix the table, Easy and convenient to operate.
6. Heavy Duty construction, built of FC35 cast iron. Suitable for heavy duty machining.

**Applications:**

1. Suitable for horizontal milling, boring machine on precision machining of division.
2. More functions for cooperate with Induction Block and Spring Block. (See the detail of Option Accessories)

Unit:mm

| MODEL NO.                          | EEPM-300IT                        | EEPM-470IT                          | EEPM-600IT | EEPM-800IT |
|------------------------------------|-----------------------------------|-------------------------------------|------------|------------|
| L X W                              | 300x300                           | 470x470                             | 600x600    | 800x800    |
| HEIGHT                             | 193                               | 187                                 | 226        | 302        |
| DRIVING                            | FLOATATION                        | Air Pressure 5~8 kg/cm <sup>2</sup> |            |            |
|                                    | REVOLVING                         | Manual                              |            |            |
| MAX. LOAD WEIGHT VERTICAL IN THEOR | 1200kg                            | 2400kg                              | 3400kg     | 4500kg     |
| ALLOWABLE LOAD WEIGHT              | 500kg                             | 1000kg                              | 2000kg     | 3000kg     |
| TABLE ROTATION                     | Clockwise & anticlockwise         |                                     |            |            |
| DIVISION                           | Standard 24T~15°<br>Option 72T~5° | Standard 72T~5° / Option 360T~1°    |            |            |
| NET WEIGHT                         | 104kg                             | 223kg                               | 453kg      | 983kg      |
| DIMENTION OF POLE                  | 50x50                             |                                     |            |            |
| NO. OF POLE                        | 16                                | 48                                  | 72         | 144        |
| TOTAL HOLDING POWER kgf ±5%        | 5000                              | 15000                               | 22500      | 45000      |
| VOLTAGE (Single Phase)             | AC 220V                           |                                     |            |            |
| CURRENT (AMP)                      | 15A                               | 23A                                 | 23A        | 18A        |
| CONTROLLER (included)              | C1                                | C2                                  | C4         | C8         |
| VOLTAGE (Single Phase)             | AC 380V~440V                      |                                     |            |            |
| CURRENT (AMP)                      | 13A                               | 10A                                 | 18A        | 18A        |
| CONTROLLER (included)              | C1                                | C2                                  | C2         | C4         |





單位：mm

| MODEL NO.             |             | EEPM-300IT | EEPM-470IT | EEPM-600IT | EEPM-800IT |
|-----------------------|-------------|------------|------------|------------|------------|
| SQUARENESS OF TABLE   |             | 0.01       | 0.015      | 0.02       | 0.02       |
| REPEAT ROTATION       |             | 0.01       | 0.01       | 0.015      | 0.015      |
| PARALLELISM OF TABLE  |             | 0.01       | 0.015      | 0.02       | 0.02       |
| BASIC SIDE SQUARENESS |             | 0.015      | 0.015      | 0.02       | 0.02       |
| DIVISION<br>(SECOND)  | DIVIDING 4  |            |            |            | ±2"        |
|                       | DIVIDING 72 |            |            |            | ±3"        |

**Working Example**

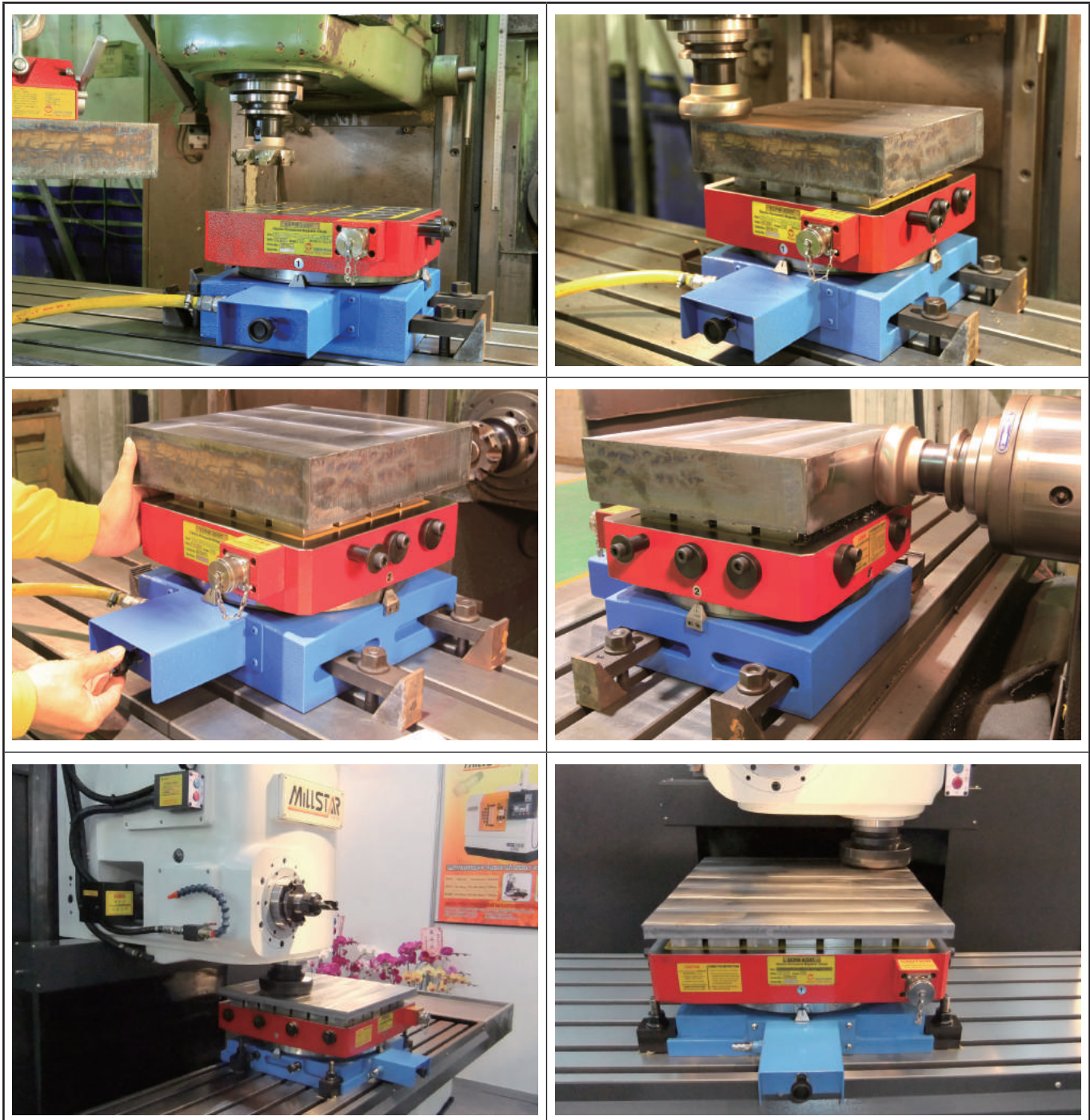

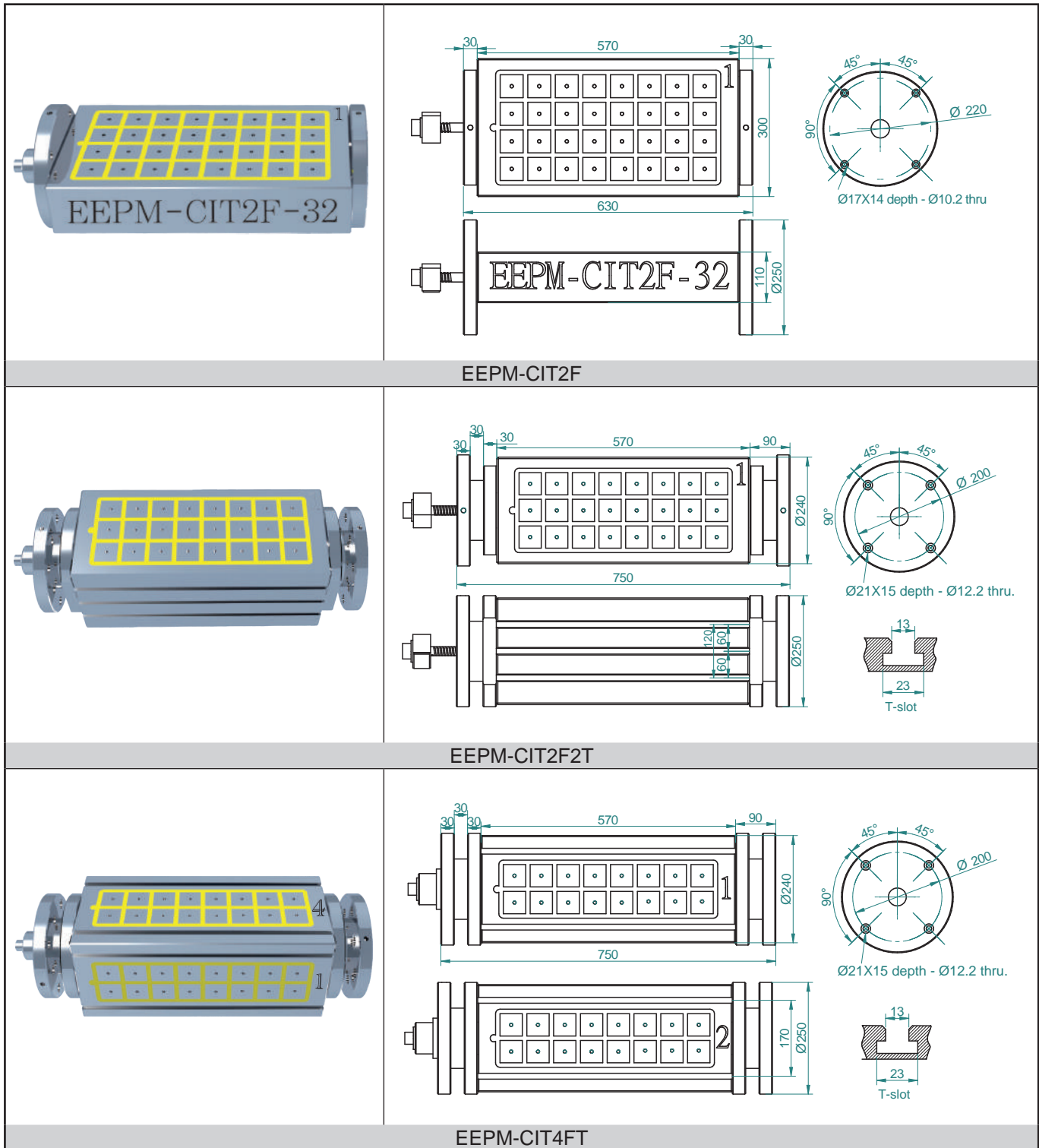

Unit:mm

| MODEL NO.    | DIMENSION | PITCH | POLE  | NO. OF POLE | TOTAL HOLDING POWER kgf ±5% | CHUCK N.V. | VOLTAGE (Single Phase) | CURRENT AMP | CONTROLLER (included) | VOLTAGE (Single Phase) | CURRENT AMP | CONTROLLER (included) |
|--------------|-----------|-------|-------|-------------|-----------------------------|------------|------------------------|-------------|-----------------------|------------------------|-------------|-----------------------|
| EEPM-CIT2F   | 300x570   | 10    | 50x50 | 32x2        | 10000                       | 141kg      | AC 220V                | 30A         | C2-2C1                | AC 380V                | C2-2C1      | C2                    |
| EEPM-CIT2F2T | 240x570   | 10    | 50x50 | 24x2        | 7500                        | 228kg      |                        | 23A         | C2-2C1                |                        | C2-2C1      | C2                    |
| EEPM-CIT4FT  | 240x570   | 10    | 50x50 | 16x4        | 5000                        | 219kg      |                        | 20A         | C4-4C1                | 440V                   | C4-4C1      | C4                    |

Custom-made is available.





**Features:**

1. Super power magnetic force 1250kgf/100cm<sup>2</sup> ±5%. (4 Poles)
2. Control each working face for ON and OFF, so it can be load and unload the workpiece on each working face. 3 seconds control for power ON and OFF.
3. EEPM-CIT2F with 2 magnetic working face, can be clamp 2 workpiece for machining. Suitable for bigger workpiece machining.
4. EEPM-CIT2F2T with 2 magnetic working face and 2 T-slot working face, can be clamp both of magnetic and non-magnetic material of workpiece machining. Suitable for smaller workpiece machining.
5. EEPM-CIT4FT with 4 magnetic working face and T-slots available. Suitable for smaller workpiece machining.
6. Without any obstructed movement of cutters during machining. Can be use all the functions of CNC 4 Axis Index Device completely.

**Applications:**

1. Suitable in use for combine with CNC 4 Axis Index Device.
2. Minimum size of workpiece required as 4 alternate magnetic square poles and above is necessary for optimum clamping.

**Working Example**

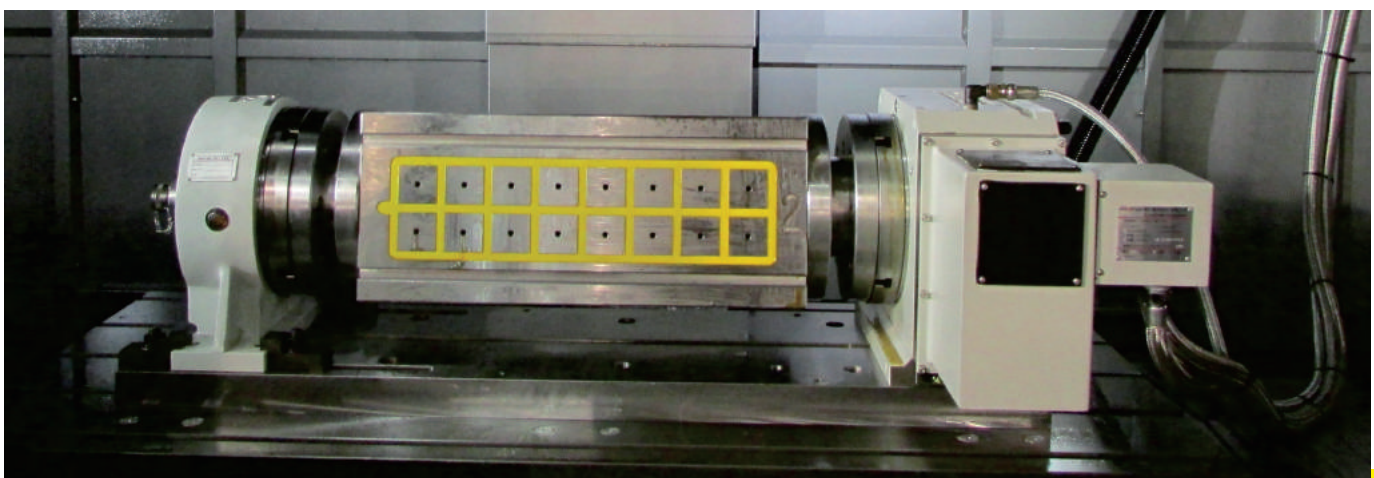
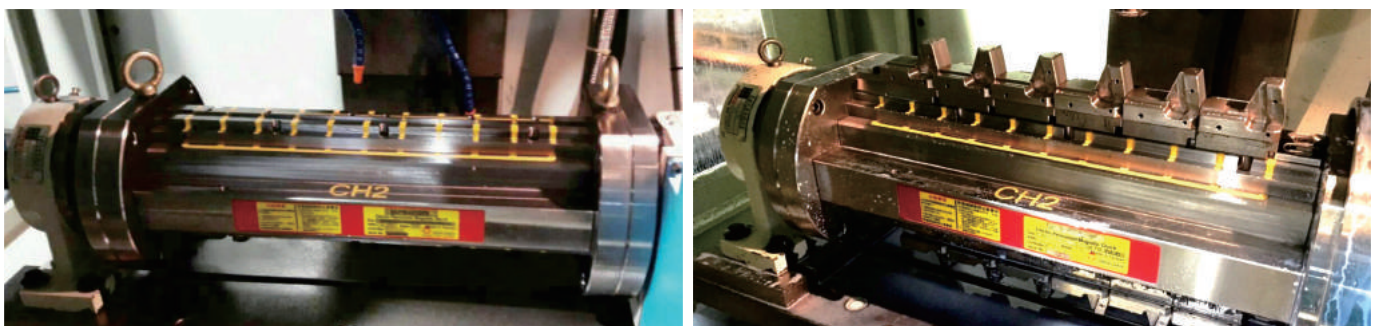
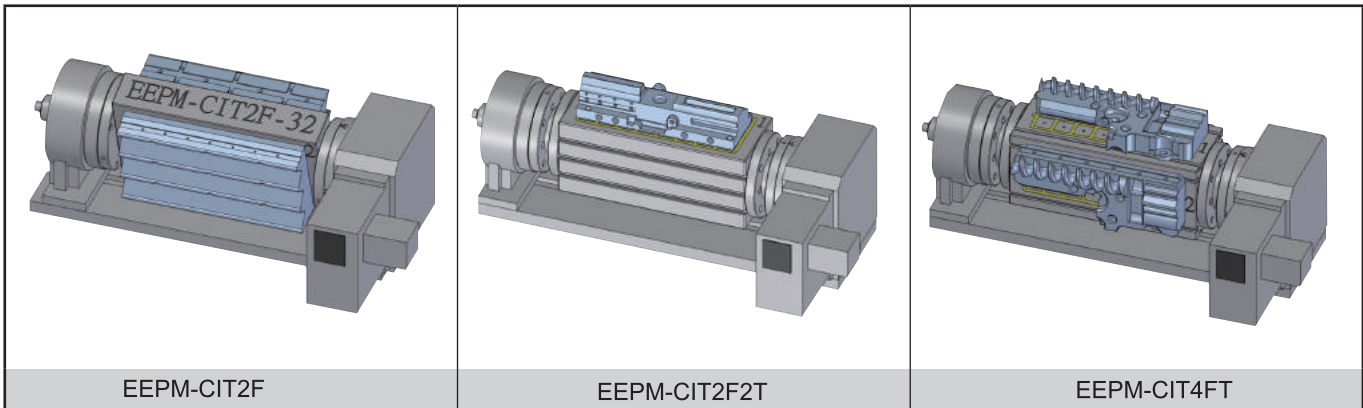



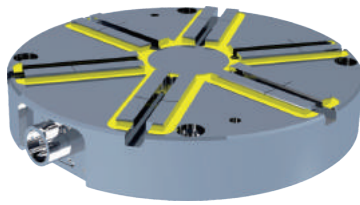
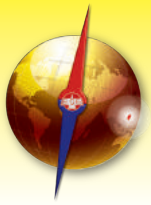

EEPМ-CIR300A

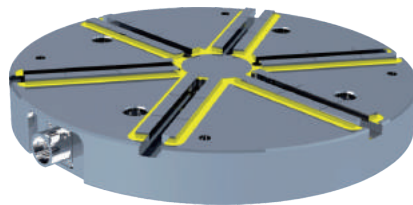

EEPМ-CIR400A

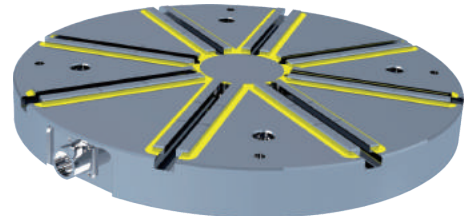

EEPМ-CIR500A

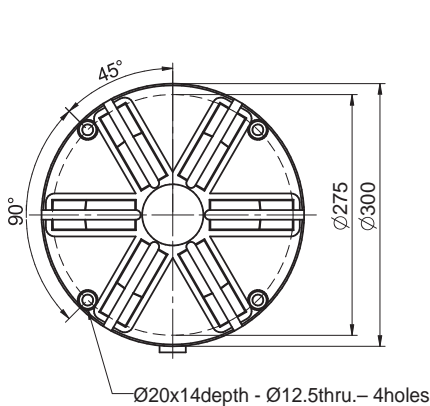

EEPМ-CIR300A

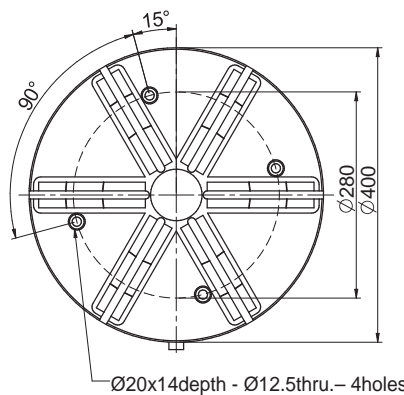

EEPМ-CIR400A

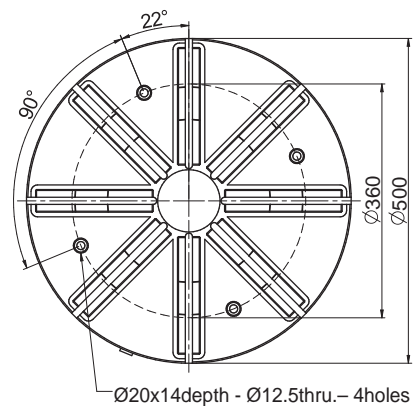

EEPМ-CIR500A

### Features:

1. Round type and radiate magnetic poles, suitable for clamping round type and any form of workpiece machining.
2. Workpieces can be touch to all poles of Magnetic Chuck, super power magnetic force as minimum of 300Kgf (0.30tons) ±5% and maximum of 2375Kgf (2.38 tons)±5%, it depends on size of workpiece and magnetic chuck. (Please refer to the spec. list)
3. 1 ~ 10 seconds control for power ON & OFF. No electric power supply required to keep the magnetic chuck ON, cable can be taken off for turning chuck freely while machining.
4. Un-obstructed movement of cutters during machining, the really functions of 5 side machining on workholding.
5. Design of Electric-Permanent, never gets temperature to effect the accuracy of workpieces.

### Applications:

1. Suitable in use for combine with Vertical Lathe, CNC 5 Axis Index Device, CNC 5 Axis Machining Center ...etc.
2. Minimum dimension of workpiece required as:  
EEPМ-CIR300- φ 300mm; EEPМ-CIR400- φ 360mm; EEPМ-CIR 500- φ 500mm  
or same dimensions of any other forms of workpiece.
3. More functions for cooperate with induction plate, can do positioning on workholding.

Panted Patent No:M358689

Unit:mm

| MODEL NO.    | DIMENSION |    |        | NO. OF POLE | T-slot | MAGNETIC FORCE | CHUCK N.W. | VOLTAGE (Single Phase) | CURRENT AMP | CONTROLLER (included) |
|--------------|-----------|----|--------|-------------|--------|----------------|------------|------------------------|-------------|-----------------------|
|              | OD        | ID | HEIGHT |             |        |                |            |                        |             |                       |
| EEPМ-CIR300A | φ 300     | 0  | 55     | 6           |        | 1600kgf±5%     | 30kg       | AC                     | 7A          | C1                    |
| EEPМ-CIR400A | φ 400     | 0  | 55     | 6           |        | 2480kgf±5%     | 55kg       | 220V                   | 18A         | C1                    |
| EEPМ-CIR500A | φ 500     | 0  | 55     | 8           |        | 4400kgf±5%     | 85kg       | 440V                   | 22A         | C1                    |

Custom-made is available.

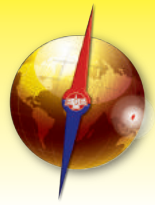

Patent Protected violators will be prosecuted: Patented Taiwan M358689

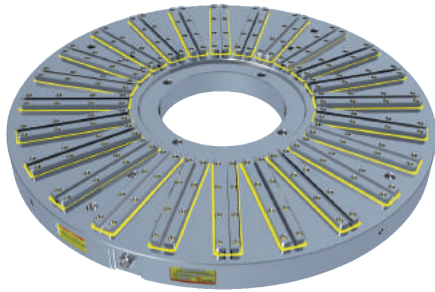

EEPM-CIR1250

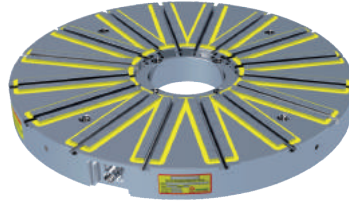

EEPM-CIR800

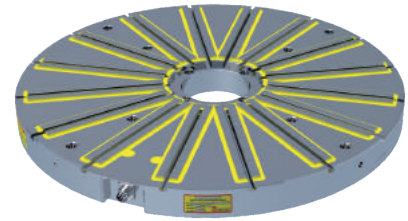

EEPM-CIR1000

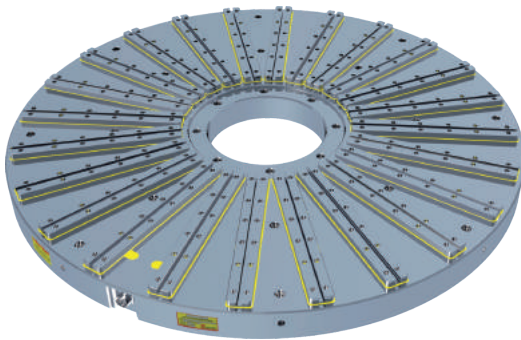

EEPM-CIR1600

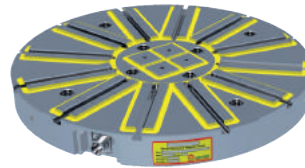

EEPM-CIR600

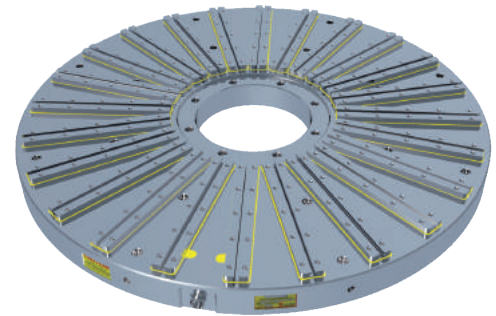

EEPM-CIR1500

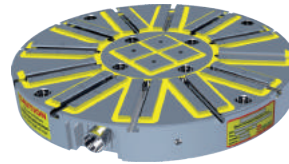

EEPM-CIR500

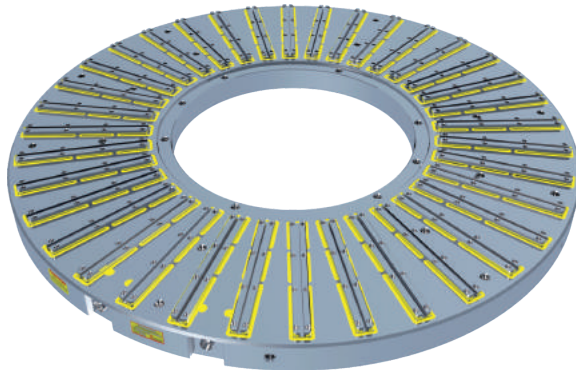

EEPM-CIR2000

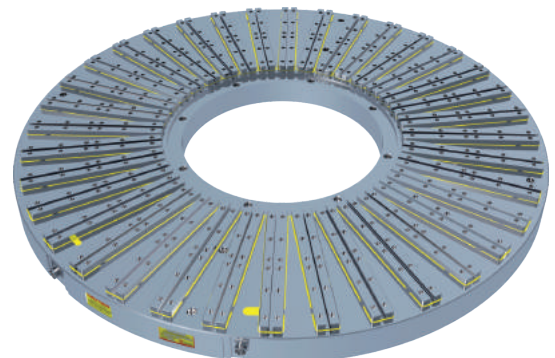

EEPM-CIR1800

Patented Patent No:M358689

Unit:mm

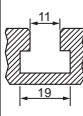
| MODEL NO.    | DIMENSION |        |        | NO. OF POLE | T-slot  | MAGNETIC FORCE | CHUCK N.W. | VOLTAGE (Single Phase) | CURRENT AMP | CONTROLLER (included) | VOLTAGE (Single Phase) | CURRENT AMP | CONTROLLER (included) |
|--------------|-----------|--------|--------|-------------|---|----------------|------------|------------------------|-------------|-----------------------|------------------------|-------------|-----------------------|
|              | OD        | ID     | HEIGHT |             |   |                |            |                        |             |                       |                        |             |                       |
| EEPM-CIR500  | φ 500     | 0      | 70     | 12/4        |  | 6650kgf±5%     | 104kg      | AC 220V                | 35A         | C1                    | AC 380V<br>~<br>440V   | 15A         | C1                    |
| EEPM-CIR600  | φ 600     | 0      | 70     | 12/4        |   | 9500kgf±5%     | 148kg      |                        | 23A         | C2                    |                        | 15A         | C2                    |
| EEPM-CIR800  | φ 800     | φ 250  | 85     | 16          |   | 15200kgf±5%    | 302kg      |                        | 30A         | C2                    |                        | 28A         | C2                    |
| EEPM-CIR1000 | φ 1000    | φ 250  | 85     | 16          |   | 19000kgf±5%    | 471kg      |                        | 24A         | C4                    |                        | 20A         | C4                    |
| EEPM-CIR1250 | φ 1260    | φ 500  | 110    | 24          |   | 28500kgf±5%    | 828kg      |                        | 33A         | C4                    |                        | 18A         | C4                    |
| EEPM-CIR1500 | φ 1520    | φ 500  | 120    | 24          |   | 39900kgf±5%    | 1325kg     |                        | 24A         | C8                    |                        | 25A         | C8                    |
| EEPM-CIR1600 | φ 1630    | φ 500  | 120    | 24          |   | 45600kgf±5%    | 1507kg     |                        | 24A         | C8                    |                        | 20A         | C8                    |
| EEPM-CIR1800 | φ 1820    | φ 800  | 120    | 36          |   | 59850kgf±5%    | 2290kg     |                        | 33A         | C8                    |                        | 28A         | C8                    |
| EEPM-CIR2000 | φ 2050    | φ 1000 | 130    | 36          |   | 59850kgf±5%    | 2490kg     |                        | 33A         | C8                    |                        | 28A         | C8                    |
| EEPM-CIR2600 |           |        |        |             |   |                |            |                        |             |                       |                        |             |                       |
| EEPM-CIR3000 |           |        |        |             |   |                |            |                        |             |                       |                        |             |                       |

Custom-made is available.



**Dimension of screw holes for setting up**

Panted Patent No:M358689

|  |  |  |
|--|--|--|
| <p>Ø 25x18depth - Ø16.5 thru. - 24 holes</p> | <p>Ø 25x18depth - Ø16.5 thru. - 18 holes</p> | <p>Ø 25x18depth - Ø16.5 thru. - 24 holes</p> |
| <p><b>EEPM-CIR1600</b></p>                   | <p><b>EEPM-CIR1800</b></p>                   | <p><b>EEPM-CIR2000</b></p>                   |
| <p>Ø 25x18depth - Ø16.5 thru. - 12 holes</p> | <p>Ø 25x18depth - Ø16.5 thru. - 12 holes</p> | <p>Ø 25x18depth - Ø16.5 thru. - 12 holes</p> |
| <p><b>EEPM-CIR1000</b></p>                   | <p><b>EEPM-CIR1250</b></p>                   | <p><b>EEPM-CIR1500</b></p>                   |
| <p>Ø 25x18depth - Ø16.5 thru. - 8 holes</p>  | <p>Ø 25x18depth - Ø16.5 thru. - 8 holes</p>  | <p>Ø 25x18depth - Ø16.5 thru. - 8 holes</p>  |
| <p><b>EEPM-CIR500</b></p>                    | <p><b>EEPM-CIR600</b></p>                    | <p><b>EEPM-CIR800</b></p>                    |

**Features:**

1. Round type and radiate magnetic poles, suitable for clamping round type and any form of workpiece machining.
2. Workpieces can be touch to all poles of Magnetic Chuck, super power magnetic force as minimum of 1340Kgf (1.34tons) ±5% and maximum of 60,400Kgf (60 tons)±5%, it depends on size of workpiece and magnetic chuck. (Please refer to the spec. list)
3. 1~10 seconds control for power ON & OFF. No electric power supply required to keep the magnetic chuck ON, cable can be taken off for turning chuck freely while machining.
4. Un-obstructed movement of cutters during machining, the really functions of 5 side machining on workholding.
5. Design of Electric-Permanent, never gets temperature to effect the accuracy of workpieces.





**Applications:**

1. Suitable in use for combine with Vertical Lathe, CNC 5 Axis Index Device, CNC 5 Axis Machining Center ...etc.
2. Minimum dimension of workpiece required as:  
 EEPM-CIR500-φ 300mm ; EEPM-CIR600-φ 360mm  
 EEPM-CIR800-φ 500mm ; EEPM-CIR1000-φ 500mm  
 EEPM-CIR1250-φ 850mm ; EEPM-CIR1500-φ 850mm  
 EEPM-CIR1600-φ 1200mm ; EEPM-CIR1800-φ 1200mm  
 or same dimensions of any other forms of workpiece.
3. More functions for cooperate with induction plate, can do positioning on workholding.

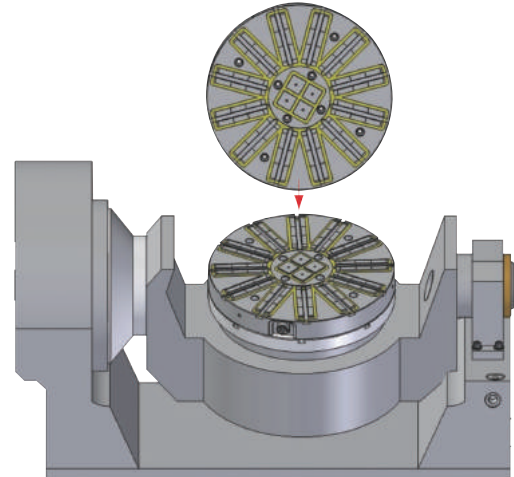

**Option Accessories-Induction Block**

**Features:**

1. Induction Block EEPM-CIRIB series are use for EEPM-CIR chucks, can do many more functions on workholding.
2. Convenience and Accuracy: Induction Block are interchanging & consuming accessories, you can machining surface or forming induction blocks for the workpiece required by the machine directly, so the parallelism of induction block will always 100% match to the machine.

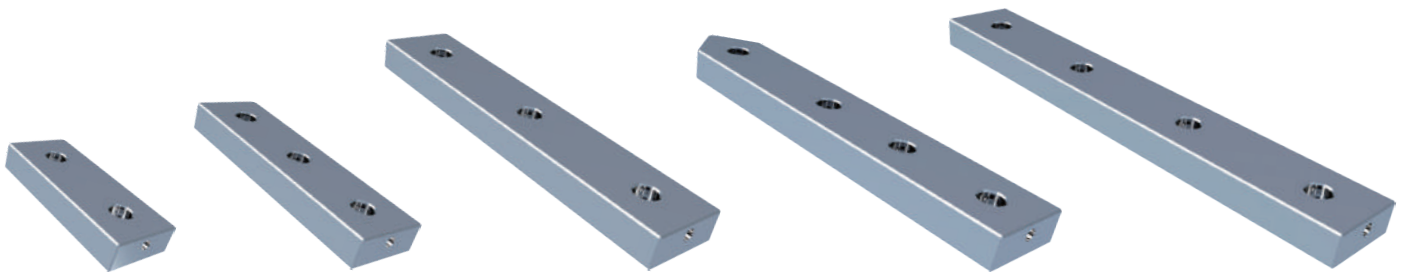

Unit:mm

| INDUCTION BLOCK | L   | W  | H  | SUITABLE     |
|-----------------|-----|----|----|--------------|
| EEPМ-CIRIB96A   | 96  | 35 | 15 | EEPМ-CIR300A |
| EEPМ-CIRIB145A  | 145 | 35 | 15 | EEPМ-CIR400A |
| EEPМ-CIRIB181A  | 181 | 35 | 15 | EEPМ-CIR500A |

Unit:mm

| INDUCTION BLOCK | L   | W  | H  | SUITABLE     |
|-----------------|-----|----|----|--------------|
| EEPМ-CIRIB120   | 120 | 50 | 20 | EEPМ-CIR500  |
| EEPМ-CIRIB170   | 170 | 50 | 20 | EEPМ-CIR600  |
| EEPМ-CIRIB245   | 245 | 50 | 20 | EEPМ-CIR800  |
| EEPМ-CIRIB335   | 335 | 50 | 20 | EEPМ-CIR1000 |
| EEPМ-CIRIB220   | 220 | 50 | 20 | EEPМ-CIR500  |
| EEPМ-CIRIB270   | 270 | 50 | 20 | EEPМ-CIR600  |

**Working Example:** ID positioning and OD machining by Induction Block.

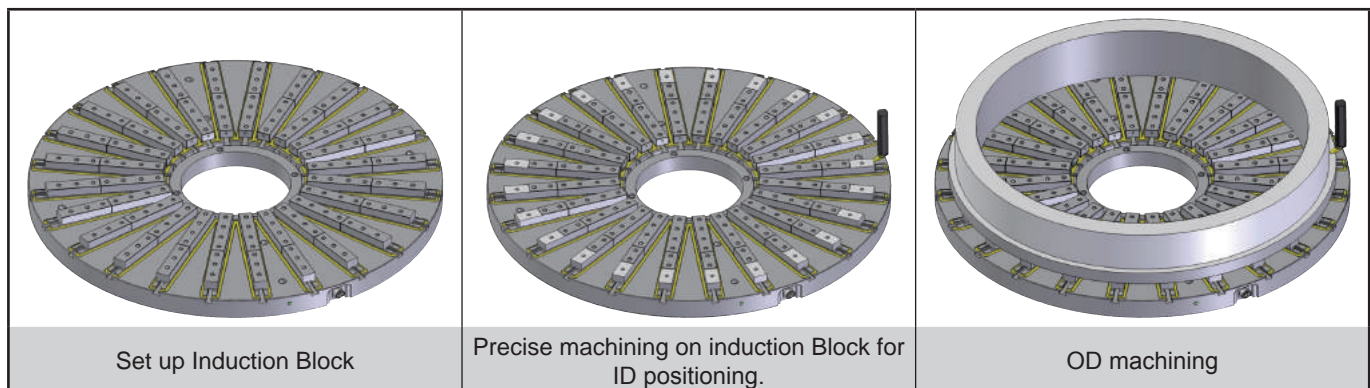

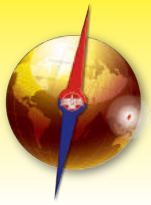

# Mag Vise

## Magnetic Workholding

### Electro-Permanent Magnetic Chuck EEPM-CIR Series

■ Suitable for use on Vertical Lathe, CNC 5 Axis Machining Center ...etc.

#### T Fixed Slide Block



EEPM-T Series

#### Features:

1. T-fixed slide block can do base points for workpiece positioning.
2. Due to the holding surface of small workpiece is not big enough, so please always use the T fixed slide Block to avoid the workpiece moving when machining.

| MODEL NO | L   | W  | H  | SUITABLE         |
|----------|-----|----|----|------------------|
| EEPM-15T | 77  | 35 | 15 | EEPM-CIRA Series |
| EEPM-20T | 120 | 50 | 20 | EEPM-CIR Series  |

#### Working Example: Vertical Lathe machining by Induction Block with T Fixed slide Block

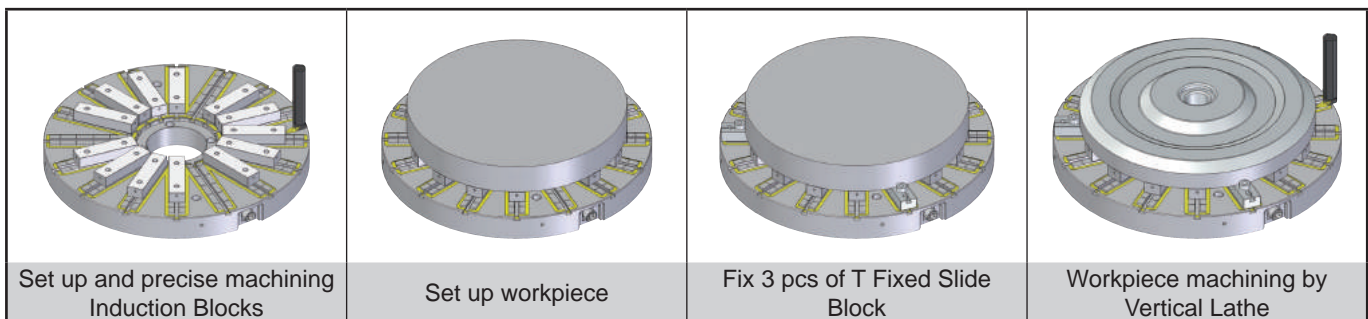

#### Spring Block \ Fixed Block

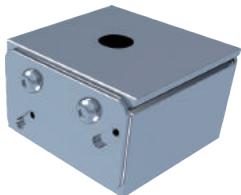

Spring Block  
EEPM-SP Series

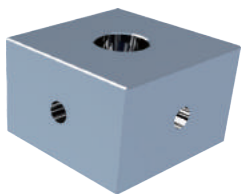

Fixed Block  
EEPM-SPF Series

#### Features:

1. Suitable for clamping on iron cast and flexuous workpieces, it will not be out of shape of the workpiece after machining.
2. 3 Fixed Blocks is necessary for each workpiece clamping, it could be makes a basic surface for the workpiece touch to the Spring Blocks.
3. Elasticity of EEPM-SP35:Each 2.0 mm for up and down.
4. Elasticity of EEPM-SP:Each 2.5 mm for up and down.

Unit:mm

| MODEL NO   | L  | W    | H  | SUITABLE         |
|------------|----|------|----|------------------|
| EEPM-SP35  | 35 | 33.6 | 21 | EEPM-CIRA Series |
| EEPM-SPF35 | 35 | 35   | 23 |                  |

Unit:mm

| MODEL NO | L  | W  | H    | SUITABLE        |
|----------|----|----|------|-----------------|
| EEPM-SP  | 48 | 48 | 30   | EEPM-CIR Series |
| EEPM-SPF | 50 | 50 | 32.5 |                 |

#### Electrical Slip Rings; Rotary union

#### Features:

For Magnetization/Demagnetization connection, installed in the center of the rear of the EEPM Chuck can be turning freely while machining.

| Model No. | Conduction     | RPM          |
|-----------|----------------|--------------|
| EEPM-RUC  | Precious metal | 0 ~ 3000 RPM |
| EEPM-V5F  | Mercury        | 0 ~ 1200 RPM |

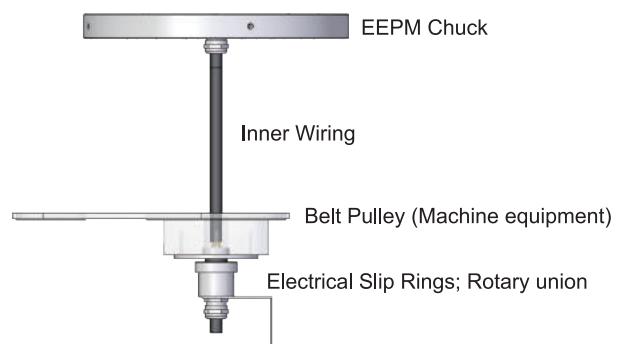

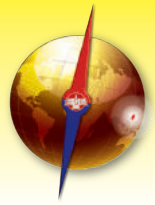

**Working Example**

|  |  |
|--|--|
|  |  |
| <p>Round type workpiece for surface, ID and OD machining by Induction Block.</p>   | <p>Irregular and thin workpiece for ID and OD machining by Spring Block.</p>       |
|  |  |
| <p>Round type workpiece positioning by OD for ID machining by Induction Block.</p> | <p>Round type workpiece positioning by ID for OD machining by Induction Block.</p> |
|  |  |
| <p>Round type spiral workpiece for complex machining by Induction Block.</p>       | <p>Round type spiral workpiece for complex machining by Induction Block.</p>       |
|  |  |
| <p>Multi-angle workpiece for 5 sides complex machining by Induction Block.</p>     | <p>Round type gear workpiece for 5 sides complex machining by Induction Block.</p> |



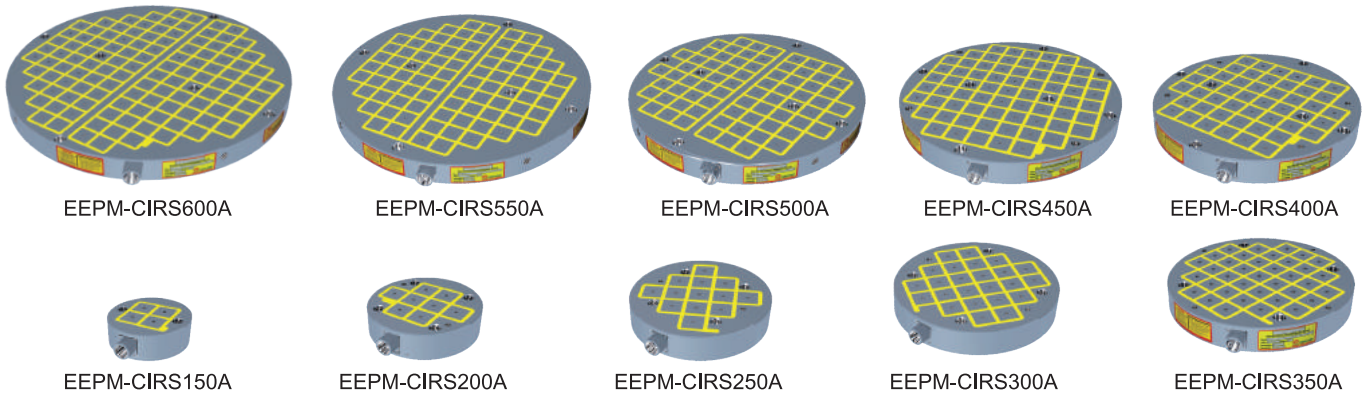

Dimension of screw holes for setting up

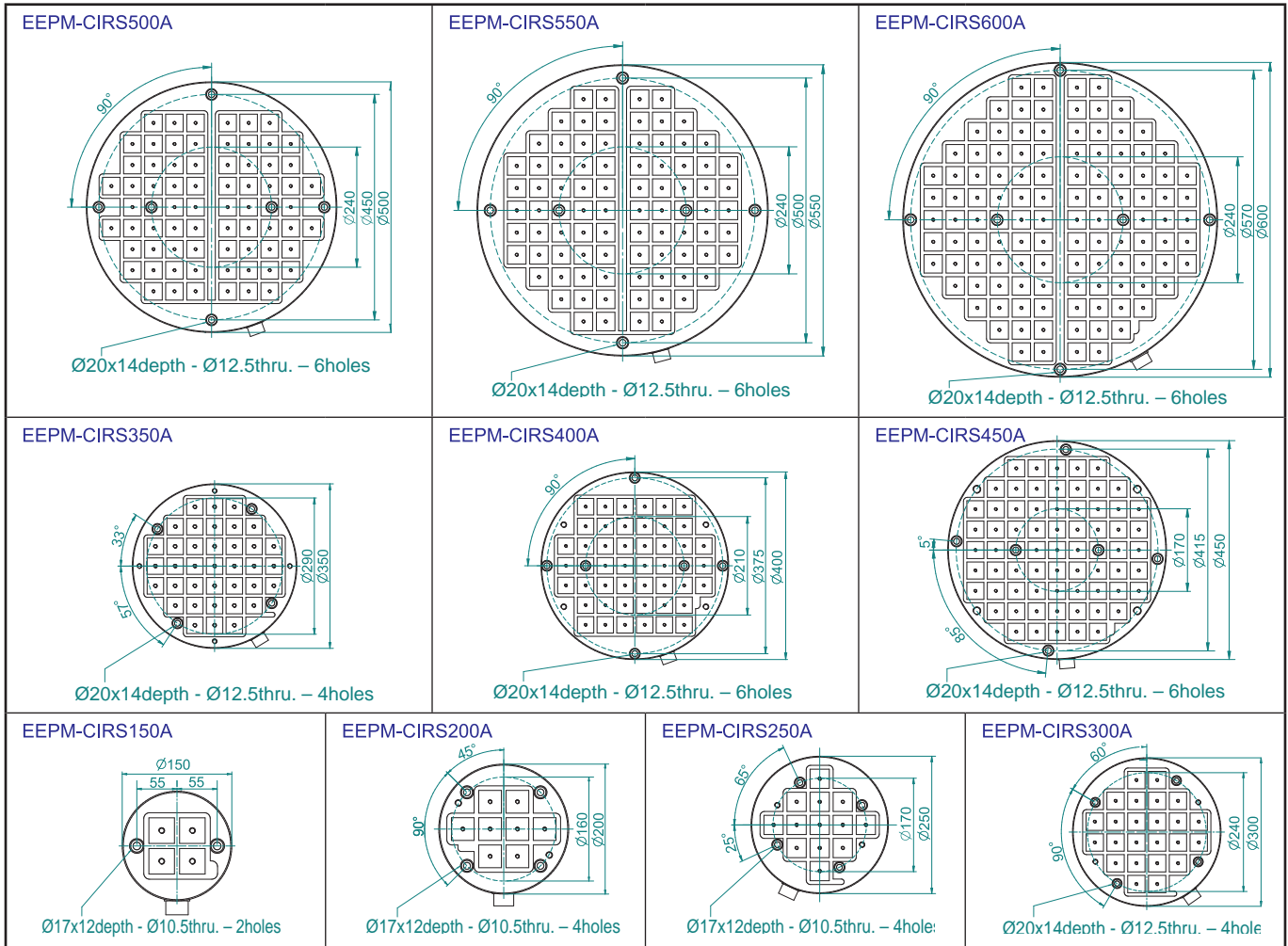

Unit:mm

| MODEL NO       | DIMENSION |        | PITCH | POLE  | NO. OF POLE | CHUCK N.W. | VOLTAGE (Single Phase) | CURRENT AMP | CONTROLLER (included) |
|----------------|-----------|--------|-------|-------|-------------|------------|------------------------|-------------|-----------------------|
|                | D         | HEIGHT |       |       |             |            |                        |             |                       |
| EEPMS-CIRS150A | φ 150     | 50     | 7     | 35x35 | 4           | 6kg        | AC 220V<br>480V        | 20A         | C1                    |
| EEPMS-CIRS200A | φ 200     | 50     | 7     |       | 8           | 11kg       |                        | 10A         | C1                    |
| EEPMS-CIRS250A | φ 250     | 50     | 7     |       | 13          | 17kg       |                        | 25A         | C1                    |
| EEPMS-CIRS300A | φ 300     | 50     | 7     |       | 24          | 25kg       |                        | 10A         | C1                    |
| EEPMS-CIRS350A | φ 350     | 50     | 7     |       | 37          | 34kg       |                        | 26A         | C1                    |
| EEPMS-CIRS400A | φ 400     | 50     | 7     |       | 46          | 44kg       |                        | 14A         | C2                    |
| EEPMS-CIRS450A | φ 450     | 50     | 7     |       | 67          | 55kg       |                        | 21A         | C2                    |
| EEPMS-CIRS500A | φ 500     | 50     | 7     |       | 70          | 69kg       |                        | 26A         | C2                    |
| EEPMS-CIRS550A | φ 550     | 50     | 7     |       | 84          | 83kg       |                        | 15A         | C4                    |
| EEPMS-CIRS600A | φ 600     | 50     | 7     |       | 114         | 99kg       |                        | --          | 23A                   |

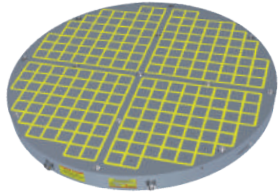
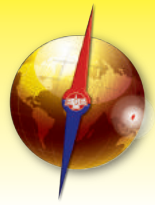

EEPM-CIRS1100

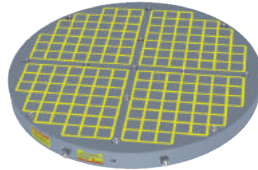

EEPM-CIRS1000

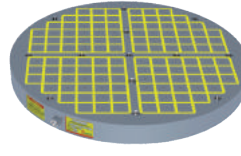

EEPM-CIRS900

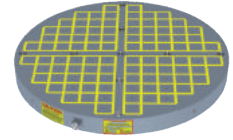

EEPM-CIRS800



EEPM-CIRS200

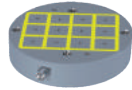

EEPM-CIRS300

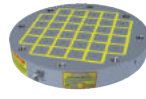

EEPM-CIRS500

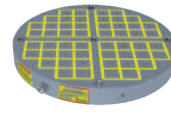

EEPM-CIRS600

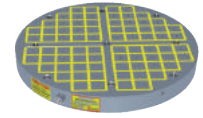

EEPM-CIRS700

Dimension of screw holes for setting up

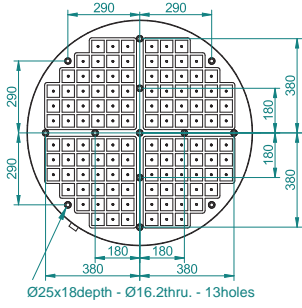
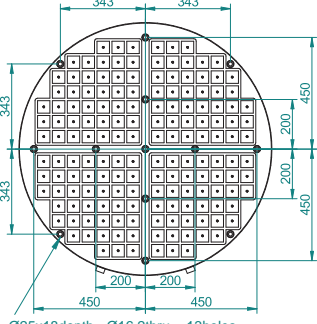
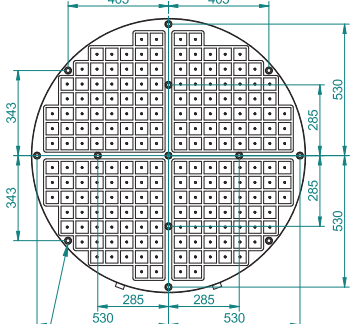
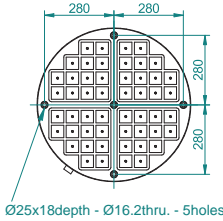
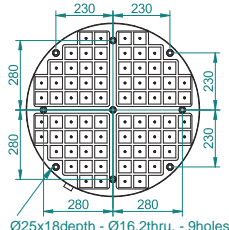
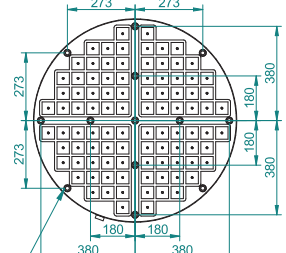
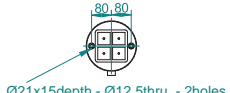
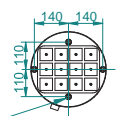
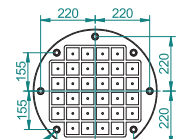
|   |  |   |
|---|--|---|
| <p>EEPM-CIRS900</p>   | <p>EEPM-CIRS1000</p>  | <p>EEPM-CIRS1100</p>  |
| <p>EEPM-CIRS600</p>  | <p>EEPM-CIRS700</p>   | <p>EEPM-CIRS800</p>  |
| <p>EEPM-CIRS200</p>  | <p>EEPM-CIRS300</p>   | <p>EEPM-CIRS500</p>  |

Unit:mm

| MODEL NO      | DIMENSION |        | PITCH | POLE  | NO. OF POLE | CHUCK N.W. | VOLTAGE (Single Phase) | CURRENT AMP | CONTROLLER (included) | VOLTAGE (Single Phase) | CURRENT AMP | CONTROLLER (included) |
|---------------|-----------|--------|-------|-------|-------------|------------|------------------------|-------------|-----------------------|------------------------|-------------|-----------------------|
|               | D         | HEIGHT |       |       |             |            |                        |             |                       |                        |             |                       |
| EEPM-CIRS200  | φ 203     | 70     | 10    | 50x50 | 4           | 16kg       | AC 220V                | 15A         | C1                    | AC 380V<br>440V        | --          | --                    |
| EEPM-CIRS300  | φ 320     | 70     | 10    |       | 12          | 35kg       |                        | 20A         | C1                    |                        | 5A          | C1                    |
| EEPM-CIRS500  | φ 500     | 70     | 10    |       | 32          | 97kg       |                        | 30A         | C1                    |                        | 15A         | C1                    |
| EEPM-CIRS600  | φ 620     | 70     | 10    |       | 52          | 150kg      |                        | 21A         | C2                    |                        | 22A         | C2                    |
| EEPM-CIRS700  | φ 720     | 70     | 10    |       | 76          | 191kg      |                        | 21A         | C4                    |                        | 10A         | C4                    |
| EEPM-CIRS800  | φ 820     | 70     | 10    |       | 96          | 262kg      |                        | 23A         | C4                    |                        | 9A          | C4                    |
| EEPM-CIRS900  | φ 900     | 80     | 10    |       | 120         | 362kg      |                        | 33A         | C4                    |                        | 18A         | C4                    |
| EEPM-CIRS1000 | φ 1020    | 80     | 10    |       | 164         | 464kg      |                        | 29A         | C8                    |                        | 27A         | C8                    |
| EEPM-CIRS1100 | φ 1106    | 80     | 10    |       | 204         | 546kg      |                        | 28A         | C8                    |                        | 11A         | C8                    |

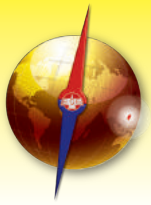

# Mag Vise

## Magnetic Workholding

### Electro-Permanent Magnetic Chuck EEPM-CIRS Series

■ Suitable in use for combine with Rotary type Surface Grinding Machine, CNC 5 Axis Machining Center ... etc.

#### Features:

1. 1~10 seconds control for power ON & OFF. No electric power supply required to keep the magnetic chuck ON, cable can be taken off for turning chuck freely while machining.
2. Un-obstructed movement of cutters during machining, the really functions of 5 side machining on workholding.

#### Applications:

1. EEPM-CIRSA: Suitable for thin & small workpiece.(Pole Size 35X35 mm, Magnetic Force 580 kgf/4 Poles).
2. EEPM-CIRS: Suitable for thin & medium workpiece.(Pole Size 50X50 mm, Magnetic Force 1250 kgf/4 Poles).
3. Minimum size of workpiece required as 4 alternate magnetic square poles and above contacts is necessary for optimum clamping.
4. More functions for cooperate with Induction Block and Spring Block.  
(See the detail of Option Accessories)



#### Option Accessories-Induction Block EEPM-IB Series

■ EEPM-IBA Suitable for use on EEPM-CIRSA Series Chucks.

Unit:mm

| MODEL NO.  | NO. OF POLE | W  | L   | HEIGHT | P  | G |
|------------|-------------|----|-----|--------|----|---|
| EEP-IB215A | 2           | 35 | 77  | 15     | 35 | 7 |
| EEP-IB315A | 3           | 35 | 119 | 15     | 35 | 7 |

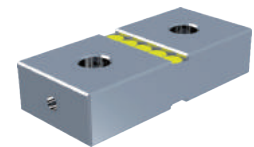
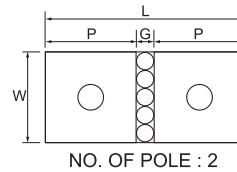

■ EEPM-IBB Suitable for use on EEPM-CIRS Series Chucks.

Unit:mm

| MODEL NO.  | NO. OF POLE | W  | L   | HEIGHT | P  | G  |
|------------|-------------|----|-----|--------|----|----|
| EEP-IB225B | 2           | 50 | 110 | 25     | 50 | 10 |
| EEP-IB325B | 3           | 50 | 170 | 25     | 50 | 10 |

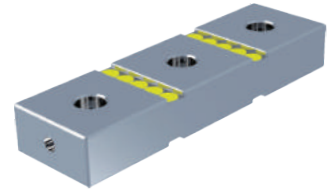
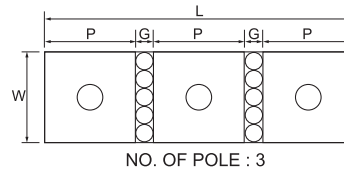

#### Relative magnetic force and EEPM-IB percentage table

| MODEL NO.  | Holding Power (Kgf) | MODEL NO.  | Holding Power (Kgf) |
|------------|---------------------|------------|---------------------|
| EEP-IB215A | 80 %                | EEP-IB225B | 82 %                |
| EEP-IB315A | 64 %                | EEP-IB325B | 68 %                |

#### Example:

| EEP-IB chuck | Induction Block | Total Holding Power         |
|--------------|-----------------|-----------------------------|
| EEP-IB500    | None            | 10,000±5% kgf               |
| EEP-IB500    | IB225B x 32pcs  | 8200±5% kgf<br>(10,000x82%) |

#### Option Accessories-Spring Block EEPM-SP Series

■ Suitable for clamping on iron cast, irregular form and flexuous workpieces, it will not be out of shape the workpiece after machining.

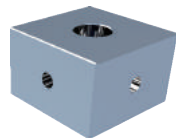

Fixed Block  
EEP-SPF Series

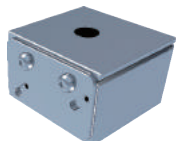

Spring Block  
EEP-SP Series

#### Features:

1. Suitable for clamping on iron cast, irregular form and flexuous workpieces, it will not be out of shape of the workpiece after machining.
2. 3 Fixed Blocks is necessary for each workpiece clamping, it could be makes a basic surface for the workpiece touch to the Spring Blocks.
3. Elasticity of EEP-SP35:Each 2.0 mm for up and down.
4. Elasticity of EEP-SP :Each 2.5 mm for up and down.

Unit:mm

| MODEL NO. | L  | W    | H  | SUITABLE         |
|-----------|----|------|----|------------------|
| EEP-SP35  | 35 | 33.6 | 21 | EEP-CIRSA Series |
| EEP-SPF35 | 35 | 35   | 23 |                  |

Unit:mm

| MODEL NO. | L  | W  | H    | SUITABLE        |
|-----------|----|----|------|-----------------|
| EEP-SP    | 48 | 48 | 30   | EEP-CIRS Series |
| EEP-SPF   | 50 | 50 | 32.5 |                 |

#### Relative magnetic force to Fixed block and Spring block:

| MODEL NO.    | Holding Power (Kgf) |
|--------------|---------------------|
| Fixed Block  | 85 %                |
| Spring Block | 40 %                |





**Electrical Slip Rings; Rotary union**

**Features:**

For Magnetization/Demagnetization connection, installed in the center of the rear of the EEPM Chuck can be turning freely while machining.

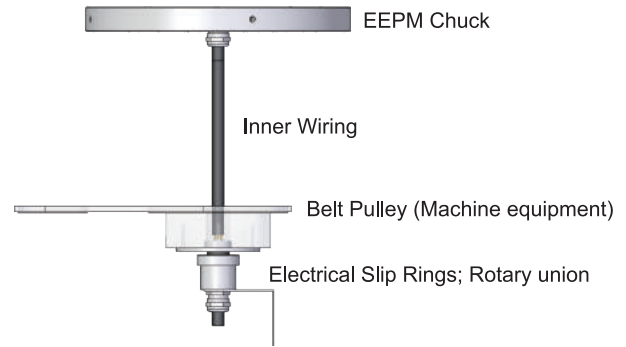

| Model No. | Conduction     | RPM          |
|-----------|----------------|--------------|
| EEPМ-RUC  | Precious metal | 0 ~ 3000 RPM |
| EEPМ-V5F  | Mercury        | 0 ~ 1200 RPM |

**Working Example**

|   |   |
|---|---|
|   |   |
| <p>Multi-form workpiece for 5 side machining by induction block.</p>  | <p>Multi-round type workpiece for precision grinding.</p> |
|   |   |
| <p>Multi-angle workpiece for 5 side machining by induction block.</p> | <p>Round type workpiece for precision grinding.</p>       |
|   |   |
| <p>Round type workpiece for precision grinding.</p>                   | <p>Square workpiece for precision grinding.</p>           |

# Mag Vise

## Electro-Permanent Magnetic Chuck EEPM-CIR & EEPM-CIRS Series



Magnetic Workholding

■ Suitable for use on Vertical Lathe, CNC 5 Axis Machining Center ...etc.

### Working Example

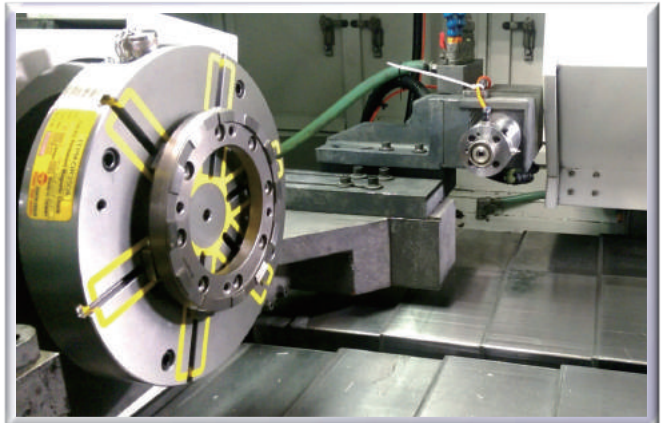
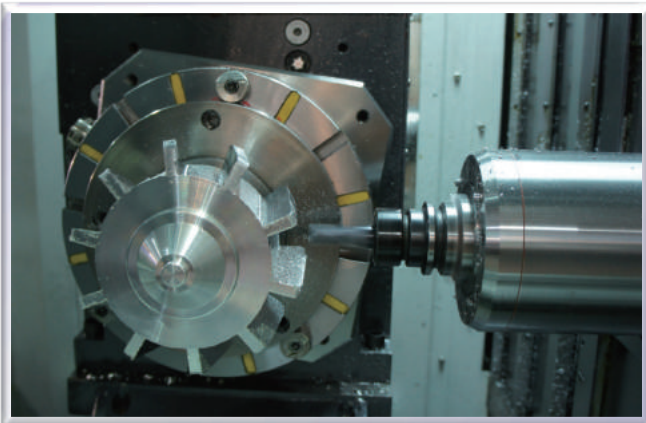
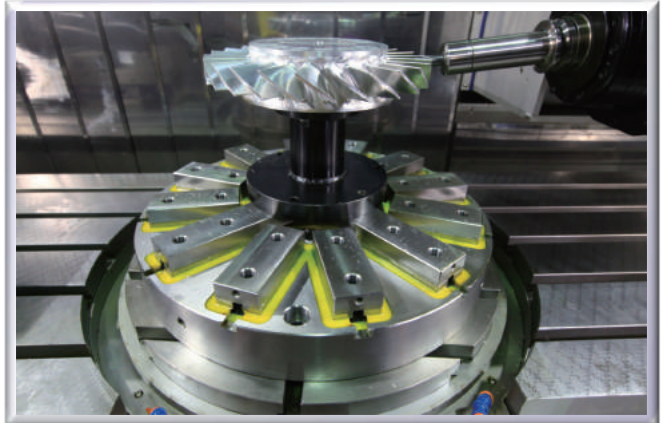
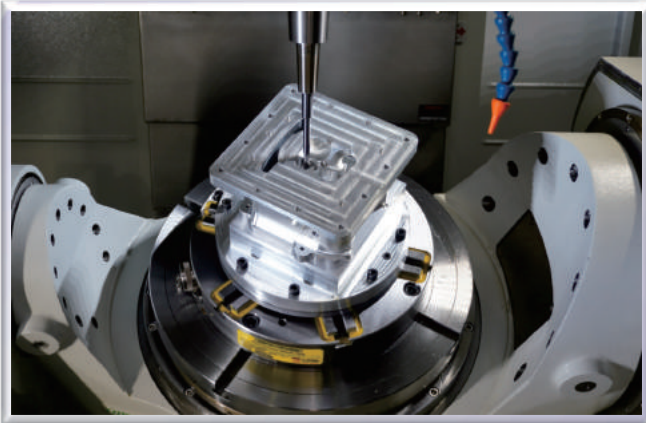
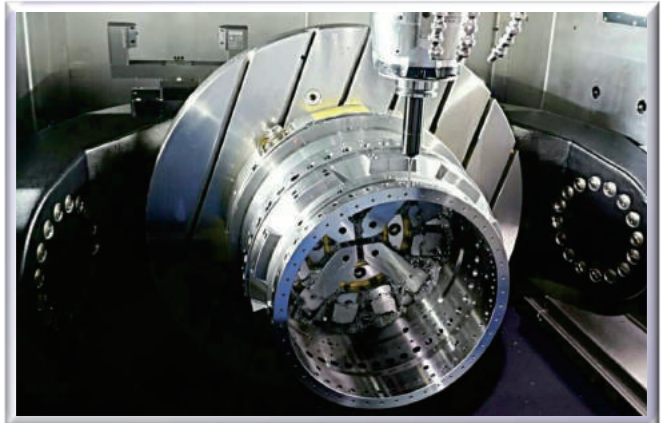
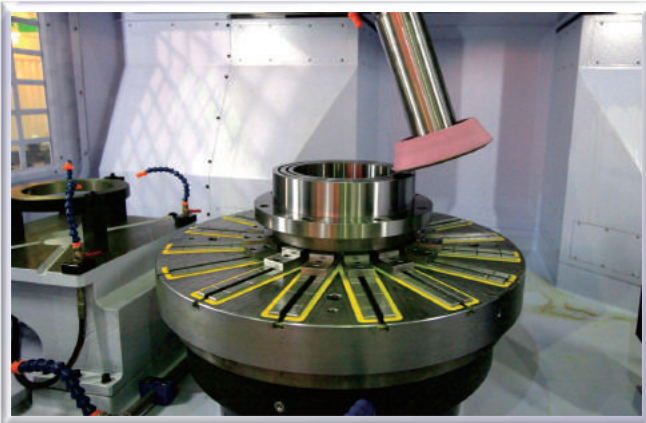
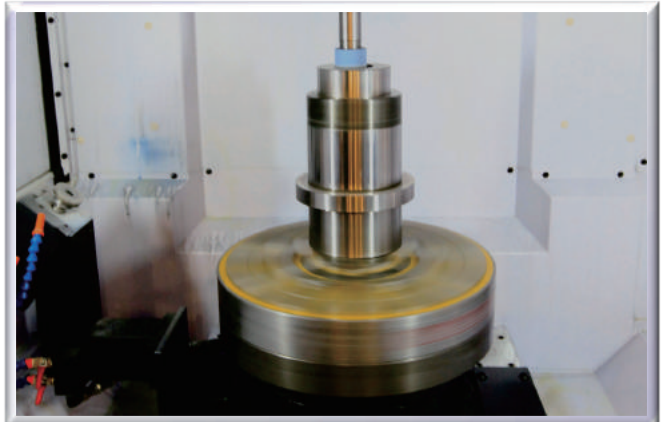
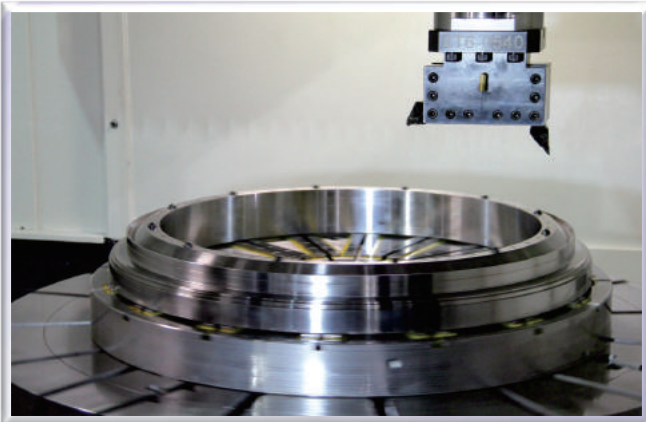



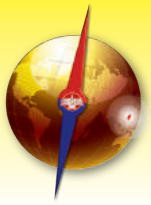

**Working Example**

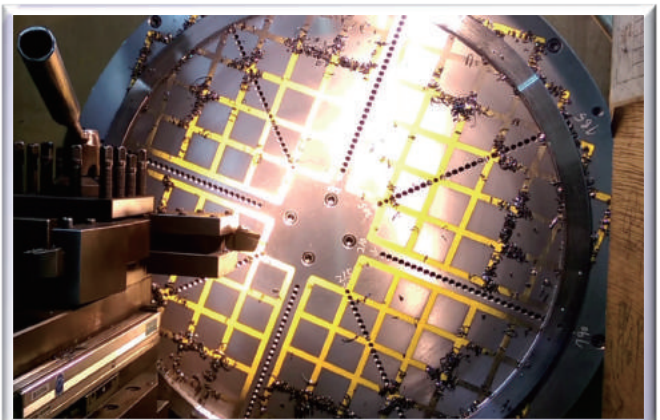
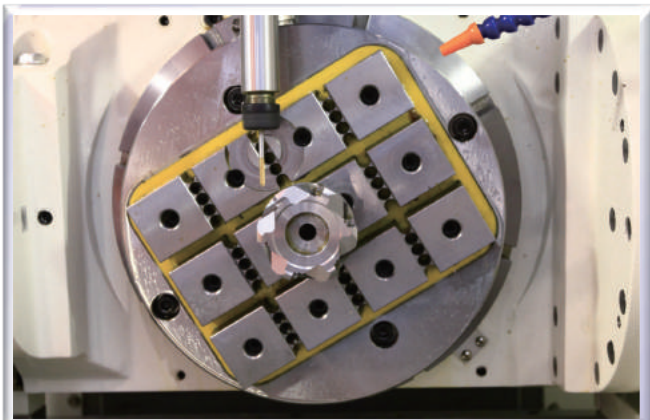
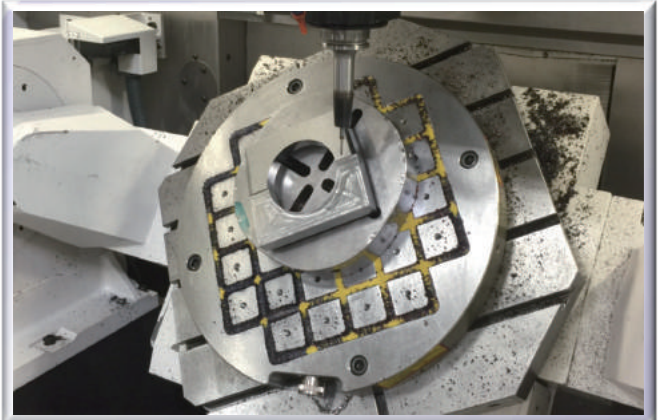
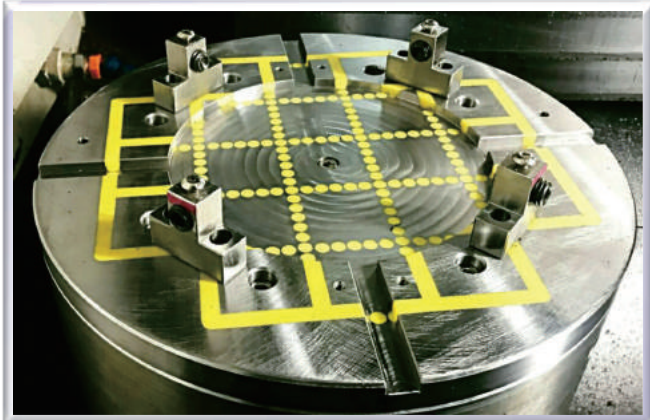
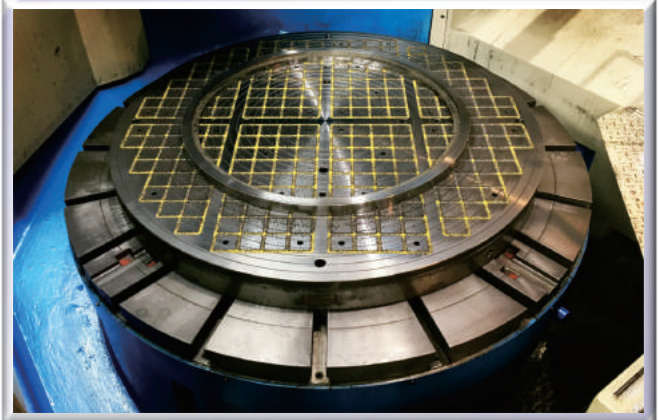
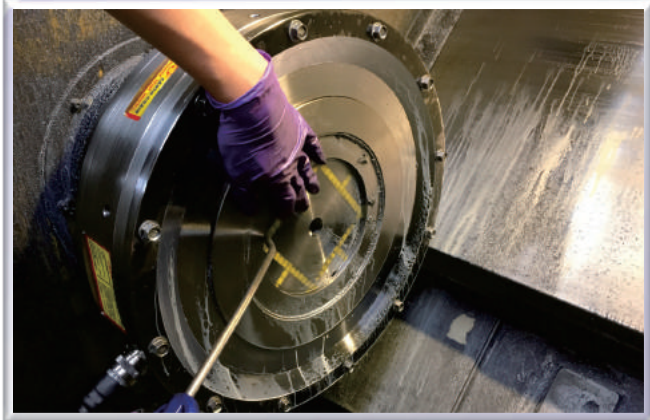
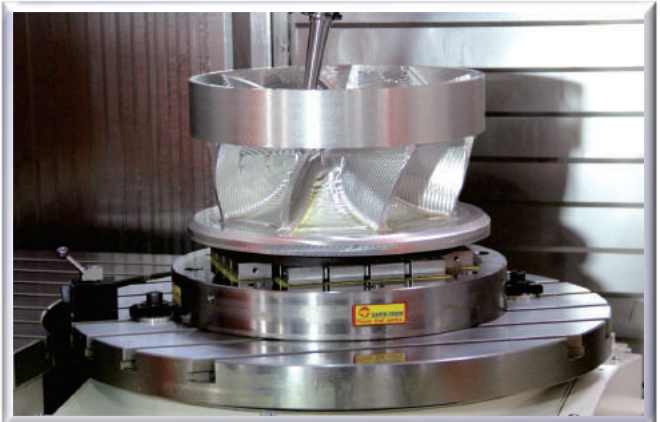





Patent Protected violators will be prosecuted: Patented Taiwan M419639, Taiwan M419639, Taiwan M447812, China 2238015, China 1653120, Japan 5465277, USA 8,905, 387, Korea 10-1458056, Italy 1414610

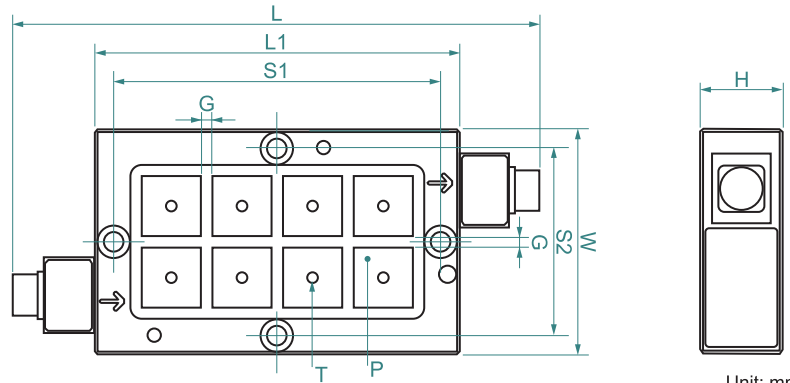
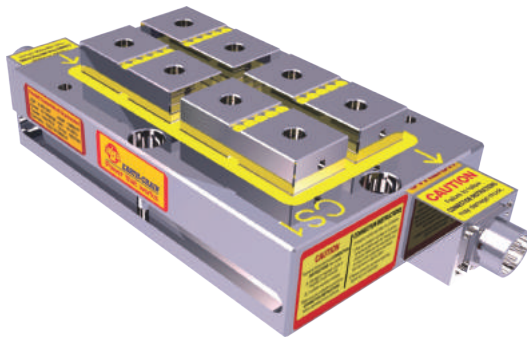

**EEPM-2030C-220V**

Unit: mm

| MODEL NO   | VOLTAGE<br>(Single Phase) | DIMENSION |     |     |     |     |    |    | PITCH<br>G | POLE<br>P | NO. OF<br>POLE | HOLDING<br>POWER | CHUCK<br>N.W. |
|------------|---------------------------|-----------|-----|-----|-----|-----|----|----|------------|-----------|----------------|------------------|---------------|
|            |                           | W         | L   | L1  | S1  | S2  | H  | T  |            |           |                |                  |               |
| EEPM-2030C | DC<br>220V                | 190       | 440 | 310 | 280 | 160 | 70 | M8 | 10         | 50x50     | 8              | 2500±5%<br>kgf   | 33.5kg        |

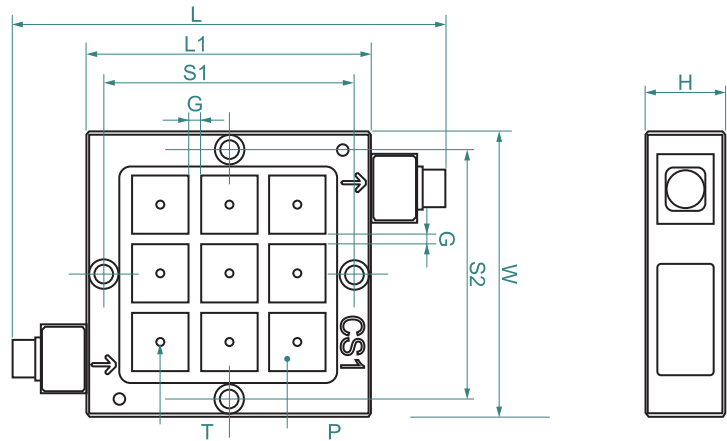
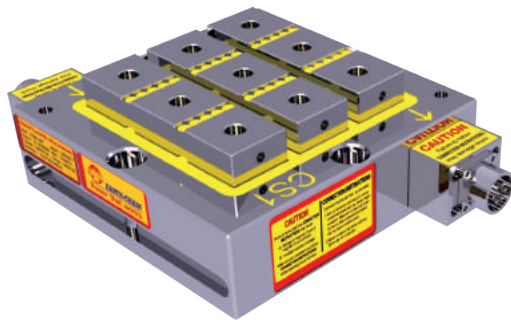

**EEPM-2525C-220V**

Unit: mm

| MODEL NO   | VOLTAGE<br>(Single Phase) | DIMENSION |     |     |     |     |    |    | PITCH<br>G | POLE<br>P | NO. OF<br>POLE | HOLDING<br>POWER | CHUCK<br>N.W. |
|------------|---------------------------|-----------|-----|-----|-----|-----|----|----|------------|-----------|----------------|------------------|---------------|
|            |                           | W         | L   | L1  | S1  | S2  | H  | T  |            |           |                |                  |               |
| EEPM-2525C | DC<br>220V                | 250       | 380 | 250 | 220 | 220 | 70 | M8 | 10         | 50x50     | 9              | 2800±5%<br>kgf   | 35.0kg        |

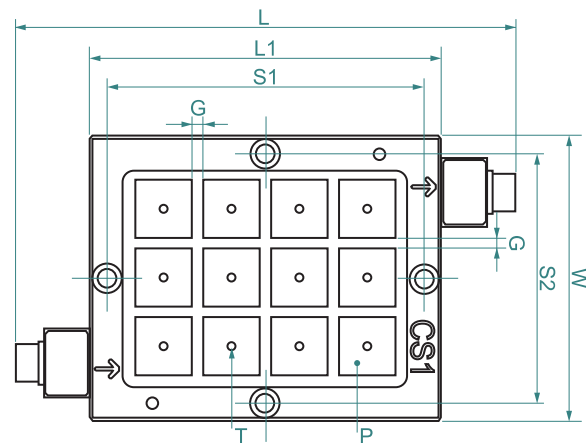

**EEPM-2530C-380V~440V**

Unit: mm

| MODEL NO   | VOLTAGE<br>(Single Phase) | DIMENSION |     |     |     |     |    |    | PITCH<br>G | POLE<br>P | NO. OF<br>POLE | HOLDING<br>POWER | CHUCK<br>N.W. |
|------------|---------------------------|-----------|-----|-----|-----|-----|----|----|------------|-----------|----------------|------------------|---------------|
|            |                           | W         | L   | L1  | S1  | S2  | H  | T  |            |           |                |                  |               |
| EEPM-2530C | DC<br>380V~DC<br>440V     | 250       | 440 | 310 | 280 | 220 | 70 | M8 | 10         | 50x50     | 12             | 3750±5%<br>kgf   | 44.0kg        |



**Features:**

1. Super power magnetic force 1250 kgf/100 cm (4 poles), can meet various machining process.
2. Structure of Electro-Permanent Magnetic Chuck, no electric power supply required to keep the chuck On, it could be used for long time and never get temperatures to affect the accuracy of workpiece.
3. Using innovation series and parallel connection modular system, EPPM-C provides a more economic solution to hold various size workpiece. Flexible units could be deployed with various quantities, locations, and distance to each other depending on customers' various workpiece shapes. Save time and cost during machining and increase the accuracy that makes the goods have higher quality and value.
4. According to the size of the workpiece point hold the workpiece, changing the magnetic fixture surface clamp the workpiece, 100% use of the chuck in an all-round way. Can reduce equipment costs and increase more profits.
5. Without any obstructed movement of cutters during machining. Can do 5-sides machining, drilling, tapping, grooving and forming can be done all in one cycle. This greatly enhances work efficiency, and reduces repeated positioning tolerances to achieve best machining accuracy.

**How to choose:**

According application requirement can choose EPPM-C Series as following steps:

1. Choose number of chucks according to Voltage and workpiece required.
2. Choose Chuck Controller.
3. Choose the Screw Size.
4. Choose the length of Chuck Connection Cables.
5. Choose the length of Power Cord.



Note: A maximum of 16 chucks can be connected to one controller. If the workpiece dimension requests more than 16 chucks please use two groups of chucks unit.

**Chuck Controller EPPM-C4C**



The controller EPPM-C4C can be control 1-16 chucks at the same time, and has the automatic detection whether the chuck cable is connection completed.

Unit: mm

| MODEL NO | VOLTAGE (Single Phase) | DIMENSION |     |     |
|----------|------------------------|-----------|-----|-----|
|          |                        | L         | W   | H   |
| EPPM-C4C | AC 220V / AC 380V~440V | 370       | 220 | 125 |

**Standard accessories Screw Size**

| T-Slot | A                                | B  | C  | D  | F  | Thread  |
|--------|----------------------------------|----|----|----|----|---------|
| 18     | 18 <sup>+0</sup> <sub>-0.3</sub> | 20 | 11 | 28 | 32 | 5/8"-11 |
| 22     | 20 <sup>+0</sup> <sub>-0.3</sub> | 26 | 14 | 32 | 38 | 5/8"-11 |
| 28     | 26 <sup>+0</sup> <sub>-0.3</sub> | 26 | 16 | 41 | 40 | 5/8"-11 |

Chuck installation direction:

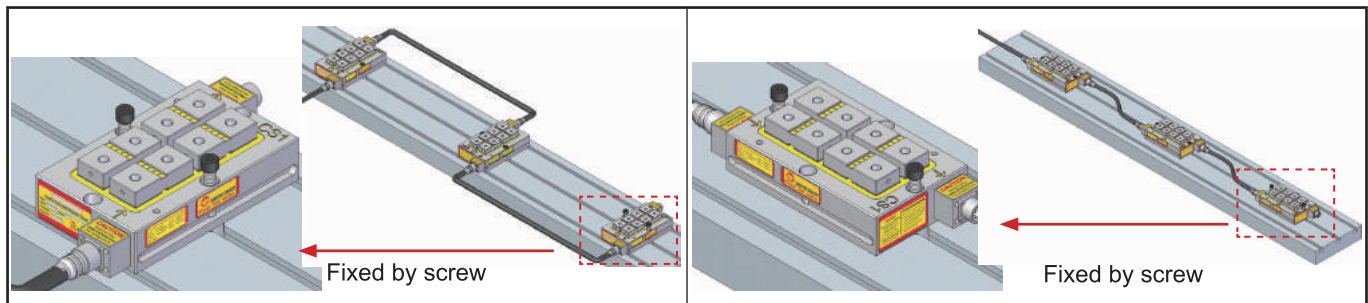



**Chuck Connection Cable**

**Standard Accessories - (Iron Flexible Conduit )**

Suitable for general machining.



| MODEL NO  | LENGTH |
|-----------|--------|
| EEPM-CC05 | 500mm  |
| EEPM-CC10 | 1000mm |
| EEPM-CC15 | 1500mm |

**Optional Accessories - ( Stainless Steel Flexible Conduit )**

Suitable for long time heavy duty machining. With high toughness and high strength preventing iron chips cut off the wire.



| MODEL NO   | LENGTH |
|------------|--------|
| EEPM-CC05B | 500mm  |
| EEPM-CC10B | 1000mm |
| EEPM-CC15B | 1500mm |

**Standard Accessories-Induction soft Block**

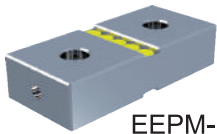

EEPM-IB225

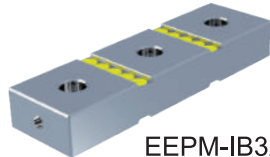

EEPM-IB325

Relative magnetic force and EEPM-IB percentage table

| MODEL NO.   | Holding Power (Kgf) |
|-------------|---------------------|
| EEPM-IB225B | 82 %                |
| EEPM-IB325B | 68 %                |

**Option Accessories-Spring Block EEPM-SP Series**

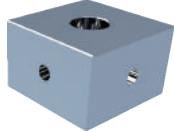

Fixed Block EEPM-SPF

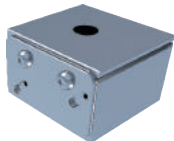

Spring Block EEPM-SP

**Features:**

1. Suitable for clamping on iron cast, irregular form and flexuous workpieces, it will not be out of shape of the workpiece after machining.
2. 3 Fixed Blocks is necessary for each workpiece clamping, it could be makes a basic surface for the workpiece touch to the Spring Blocks.
3. Elasticity: Each 2.5 mm for up and down.

Unit:mm

| MODEL NO. | L  | W  | H    |
|-----------|----|----|------|
| EEPM-SP   | 48 | 48 | 30   |
| EEPM-SPF  | 50 | 50 | 32.5 |

Relative magnetic force to Fixed block and Spring block:

| MODEL NO.    | Holding Power (Kgf) |
|--------------|---------------------|
| Fixed Block  | 85 %                |
| Spring Block | 40 %                |

**CONNECTION TABLE**

| MODEL NO   | EEPM-2030C 220V             |                             |             | EEPM-2525C 220V             |                             |             | EEPM-2530C 380V~440V        |                             |             |
|------------|-----------------------------|-----------------------------|-------------|-----------------------------|-----------------------------|-------------|-----------------------------|-----------------------------|-------------|
| CHUCK NOS. | HOLDING POWER OF EACH CHUCK | TOTAL HOLDING POWER kgf ±5% | CURRENT AMP | HOLDING POWER OF EACH CHUCK | TOTAL HOLDING POWER kgf ±5% | CURRENT AMP | HOLDING POWER OF EACH CHUCK | TOTAL HOLDING POWER kgf ±5% | CURRENT AMP |
| 3          | 2500±5%                     | 7500                        | 7A          | 2800±5%                     | 8400                        | 7A          | 3750±5%                     | 11250                       | 8A          |
| 4          |                             | 10000                       | 9A          |                             | 11200                       | 9A          |                             | 15000                       | 10A         |
| 5          |                             | 12500                       | 11A         |                             | 14000                       | 10A         |                             | 18750                       | 12A         |
| 6          |                             | 15000                       | 12A         |                             | 16800                       | 11A         |                             | 22500                       | 13A         |
| 7          |                             | 17500                       | 14A         |                             | 19600                       | 12A         |                             | 26250                       | 16A         |
| 8          |                             | 20000                       | 16A         |                             | 22400                       | 14A         |                             | 30000                       | 18A         |
| 9          |                             | 22500                       | 17A         |                             | 25200                       | 15A         |                             | 33750                       | 19A         |
| 10         |                             | 25000                       | 19A         |                             | 28000                       | 17A         |                             | 37500                       | 21A         |
| 11         |                             | 27500                       | 20A         |                             | 30800                       | 19A         |                             | 41250                       | 23A         |
| 12         |                             | 30000                       | 22A         |                             | 33600                       | 20A         |                             | 45000                       | 25A         |
| 13         |                             | 32500                       | 24A         |                             | 36400                       | 22A         |                             | 48750                       | 27A         |
| 14         |                             | 35000                       | 26A         |                             | 39200                       | 23A         |                             | 52500                       | 29A         |
| 15         |                             | 37500                       | 27A         |                             | 42000                       | 24A         |                             | 56250                       | 30A         |
| 16         |                             | 40000                       | 29A         |                             | 44800                       | 26A         |                             | 60000                       | 33A         |

If the workpiece dimension requests more than 16 chucks, please use two groups of chuck unit.

**Notice:**

1. EEPM-C Series each voltage has two specifications can be choose.
2. Maximum distance required:

| No. of EEPM-CS               | 3-4 Chucks | 5-10 Chucks | 11-16 Chucks |
|------------------------------|------------|-------------|--------------|
| Max. Distance Between Chucks | 800 mm     | 1000 mm     | 1500 mm      |





**Example of Vertical Lathe on Setting:**

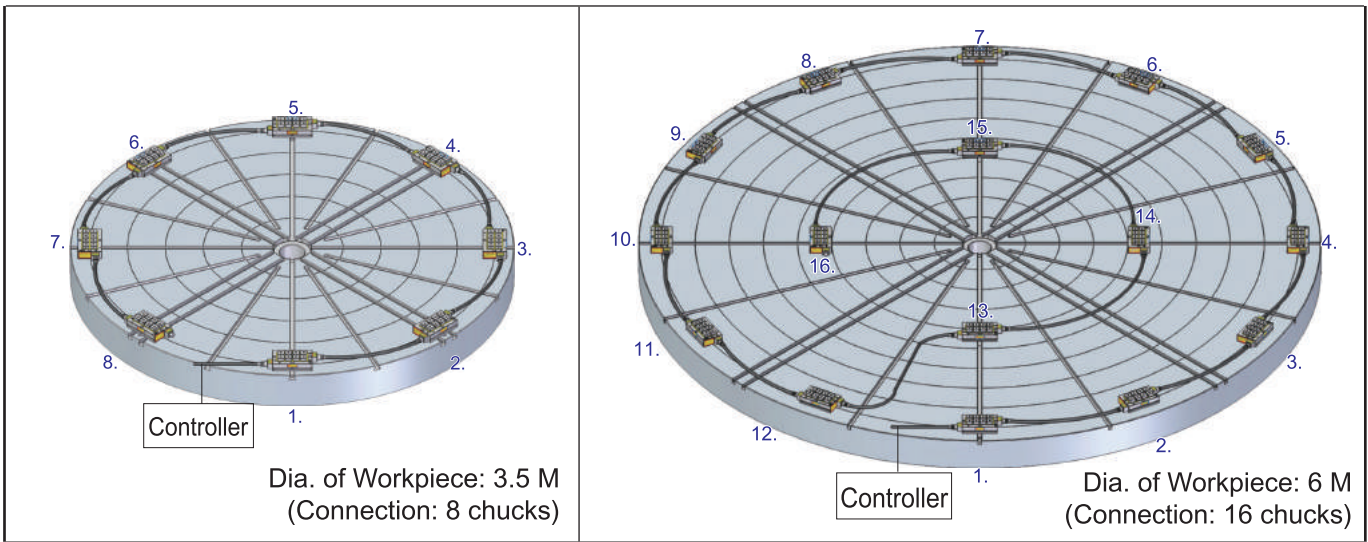

**Example of Double Column Machining Center and CNC Machining Center on Setting**

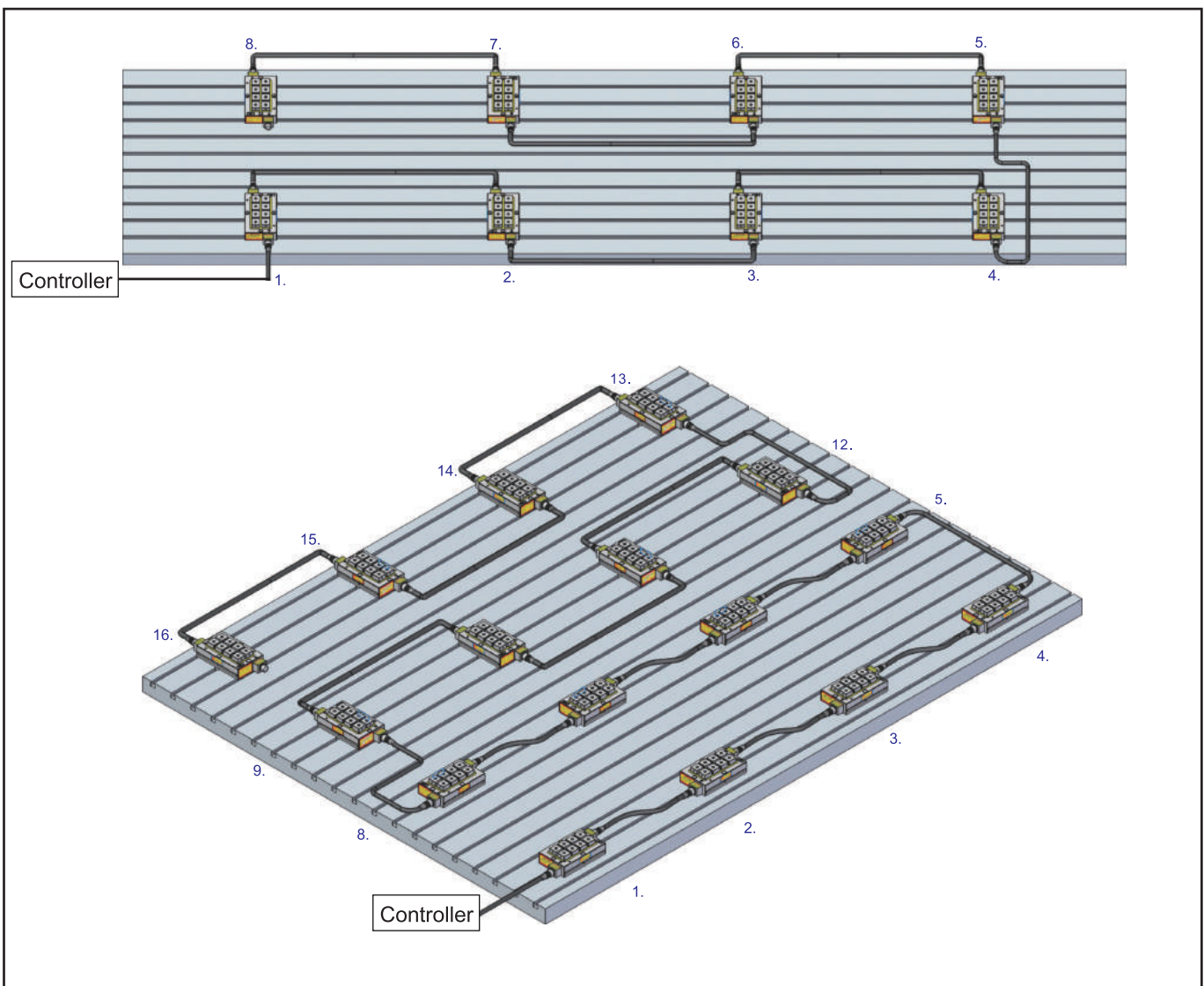



# Mag Vise

Magnetic Workholding

## Electro-Permanent Magnetic Chuck-Connection Type EPPM-C Series

■ Suitable for use on large Vertical Lathe, Double Column Machining Center and CNC Machining Center ...etc.

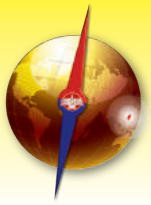

### Working Example

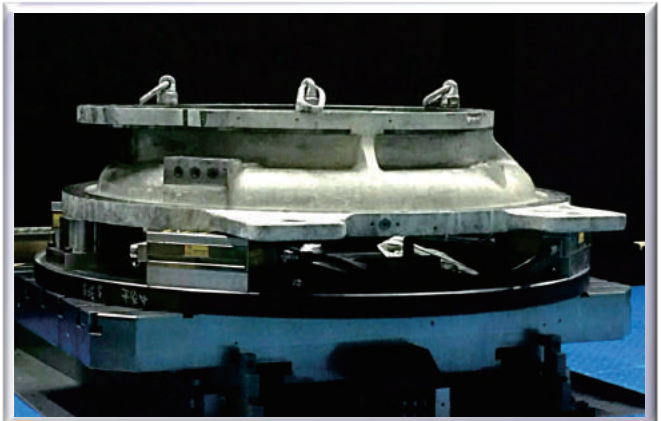
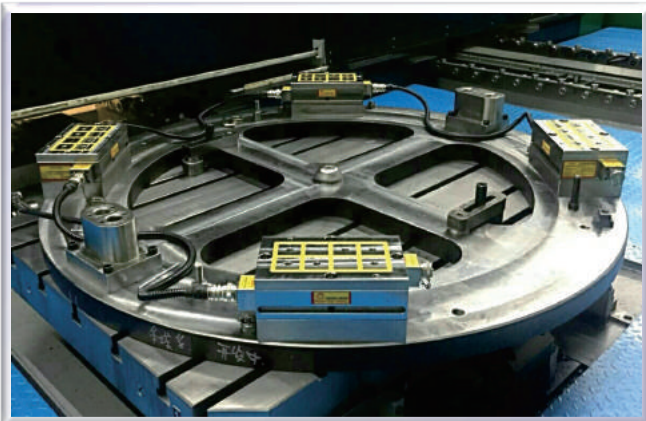
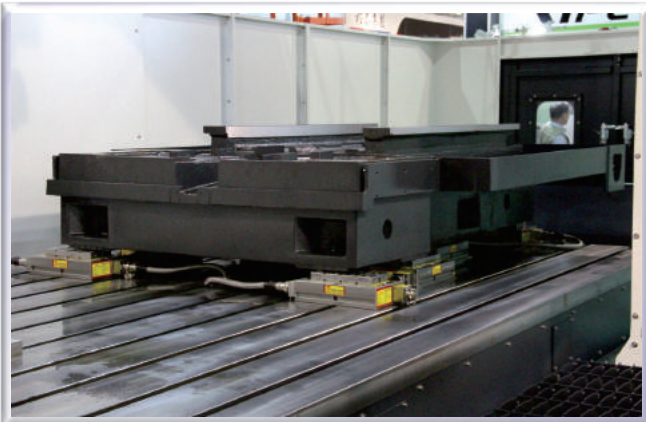
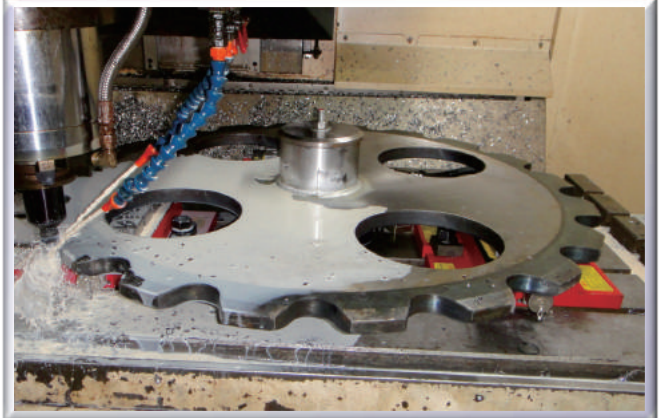
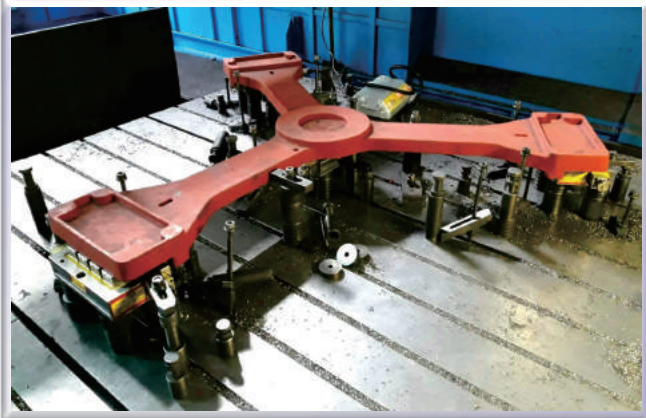
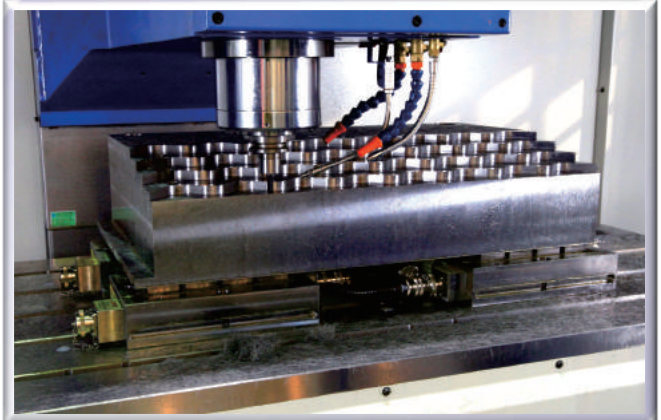





**EARTH-CHAIN**

**Power that works.**

## Electro-Permanent Magnetic Chuck-Connection Type EPPM-C Series

Suitable for use on large Vertical Lathe, Double Column Machining Center and CNC Machining Center ...etc.

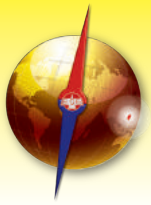

### Working Example

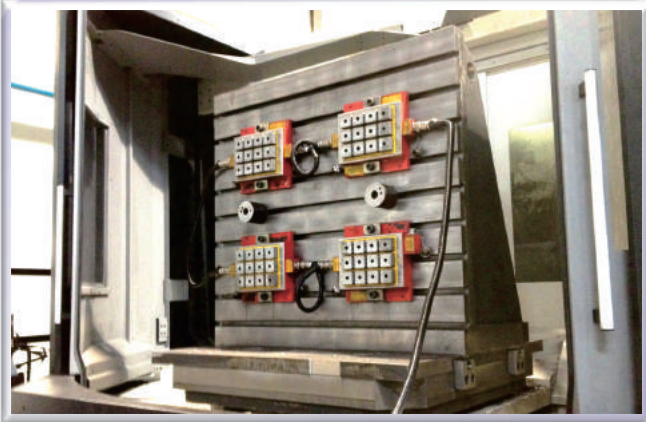
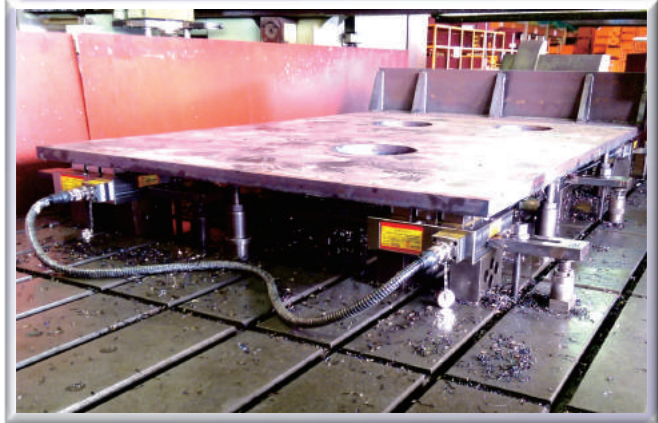
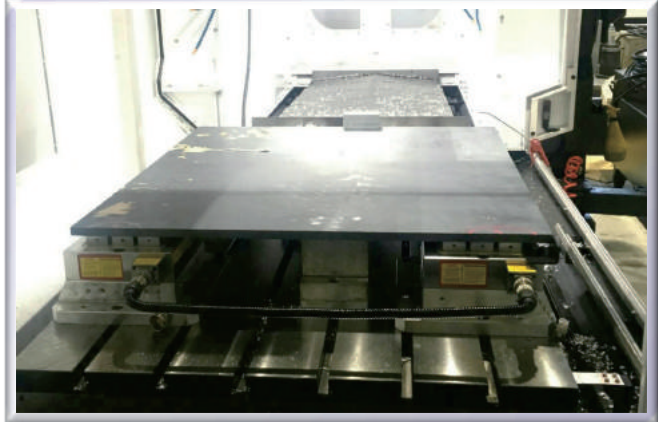
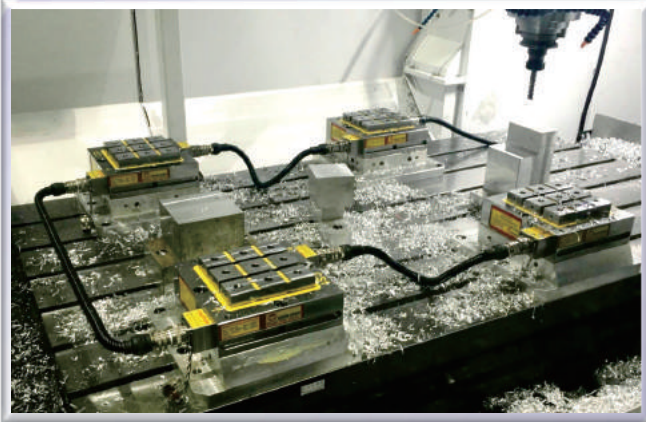
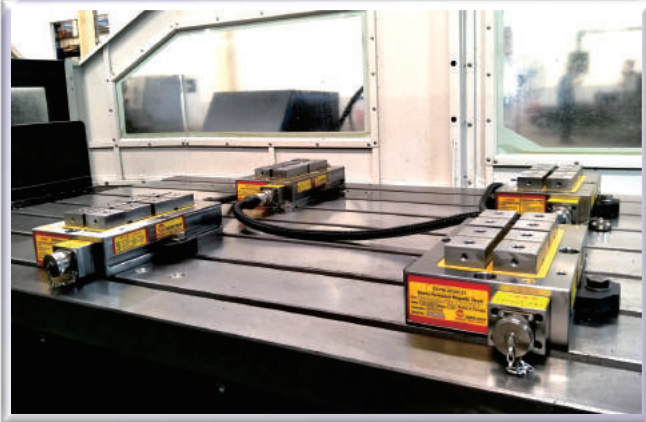





Professional R & D team-Custom-Made is available

At present, the customized products have reached more than 50%. Earth-Chain pays attentions to the services to every customer, listening to customers and tailoring the requirements for customers.



R & D



Customer Service



Quality Inspection



Precision Testing





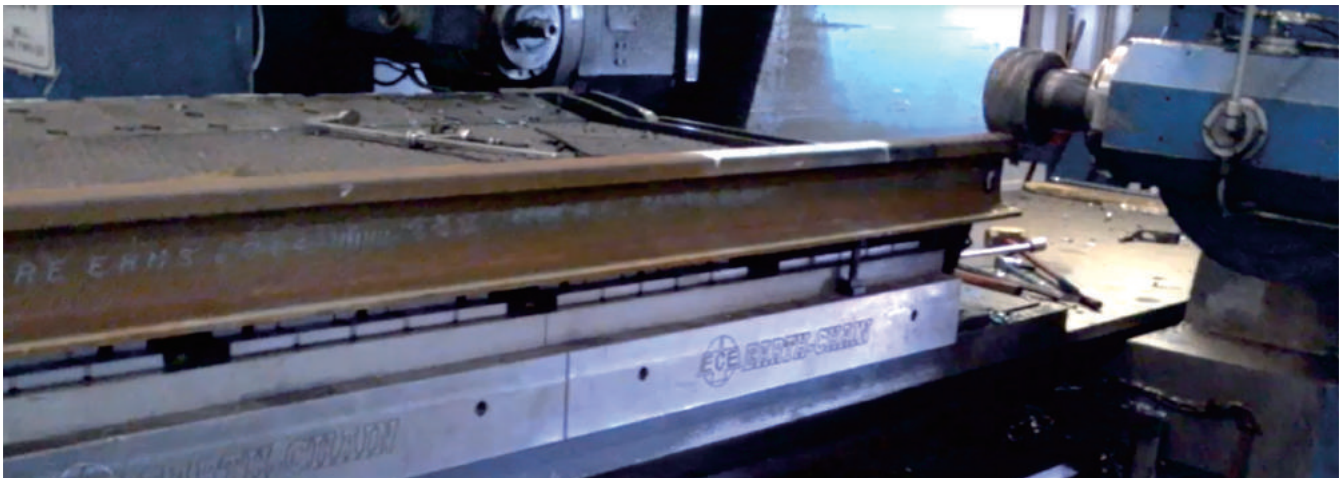
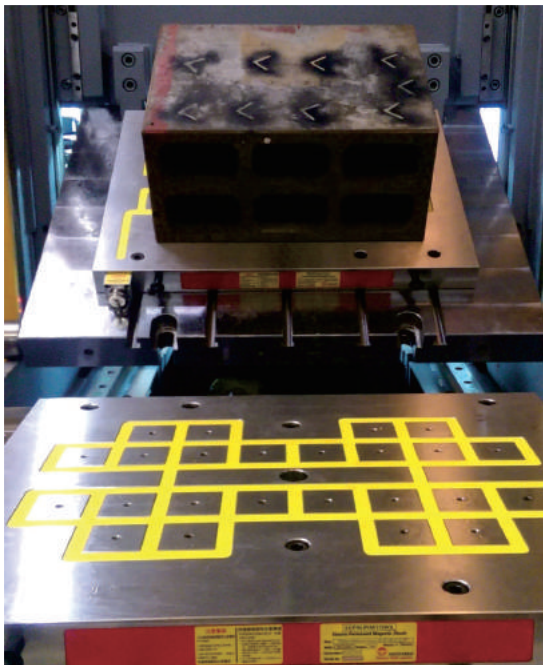
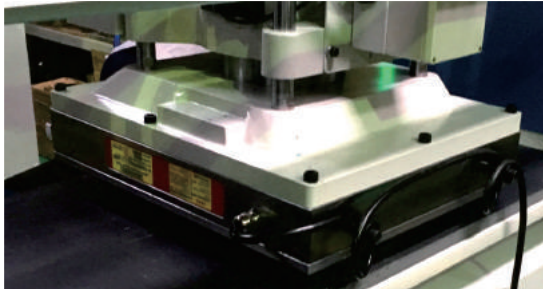
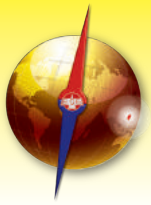

# Mag Vise

## Magnetic Workholding

### Electro-Permanent Magnetic Chuck EEPML Series

Used on Linear Guideway high precision or high accuracy long strip workpiece drilling, grinding machining...etc. (Custom-made)

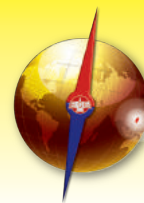

Patent Protected violators will be prosecuted: Patented Taiwan M415776, Taiwan M511830, China ZL 2013 2 0056033.9

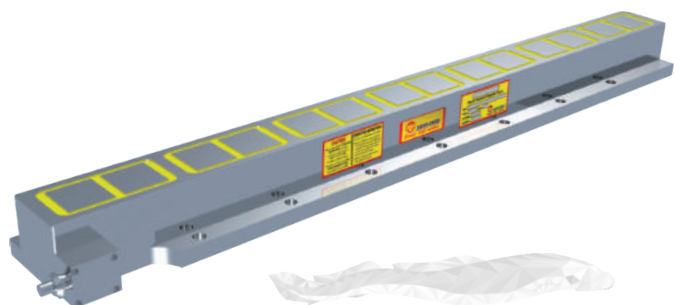

#### Applications:

##### EEPML-08102WS Series

With Lower price suitable for large sizes of precision linear guideway or long strip workpiece.

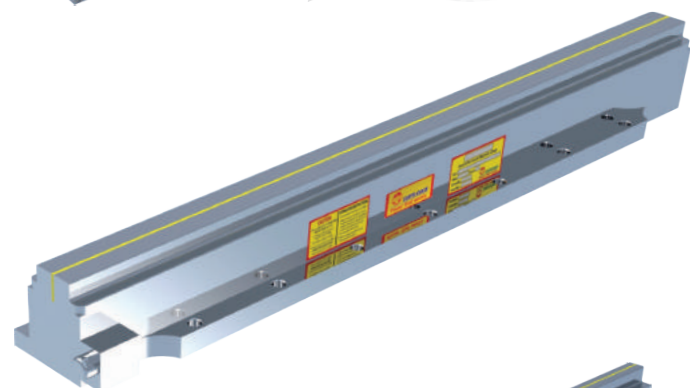

##### EEPML-11-08102 Series

1. Suitable for small, medium and large of linear guideway high precision or long strip workpieces.
2. Using Induction block can be increased the precision of linear guideway grinding.

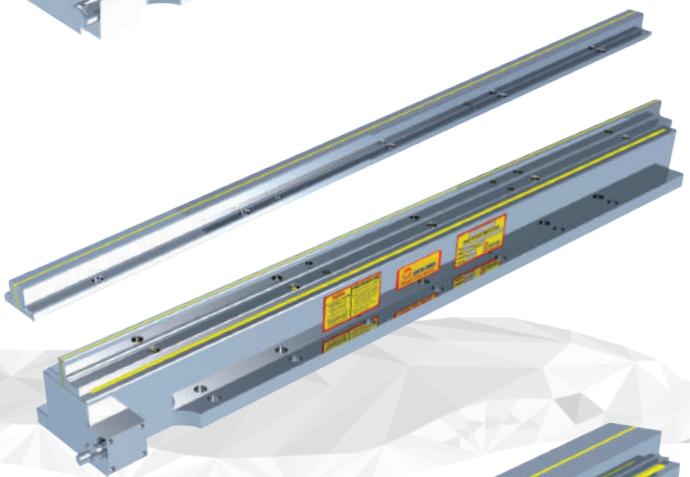

##### EEPML-11-08102-1 Series

1. Induction block is changeable, can be using for small, medium and large of linear guideway high precision or long strip workpieces.
2. Custom-made of induction block is available.

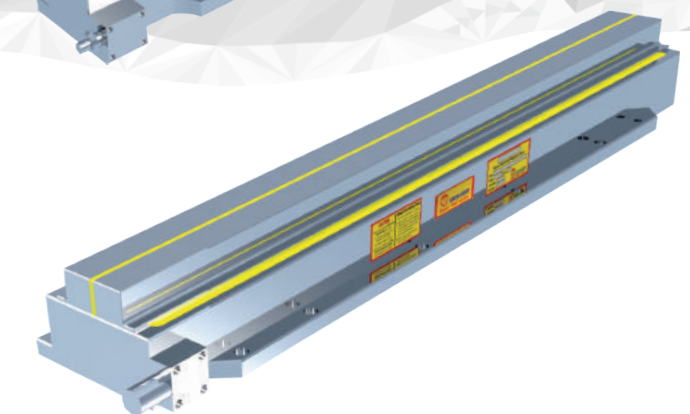

##### EEPML-15-15102 Series

1. Suitable for small, medium and large of linear guideway high precision or long strip workpieces.
2. Using Induction block can be increased the precision of linear guideway grinding.

Unit:mm

| MODEL NO.        | DIMENSION<br>L X W X H | NO. OF<br>POLE | TOTAL HOLDING<br>POWER kgf ± 5% | CHUCK<br>N.W. | VOLTAGE<br>(Single Phase) | CURRENT<br>AMP | CONTROLLER<br>(included) | VOLTAGE<br>(Single Phase) | CURRENT<br>AMP | CONTROLLER<br>(included) |
|------------------|------------------------|----------------|---------------------------------|---------------|---------------------------|----------------|--------------------------|---------------------------|----------------|--------------------------|
| EEPML-08102WS    | 1020X130X80            | 14             | 3150                            | 60kg          | AC<br>220V                | 20A            | C1                       | AC<br>380V                | 10A            | C1                       |
| EEPML-11-08102   | 1020X130X88            | 14             | 2275                            | 65kg          |                           | 20A            | C1                       |                           | 10A            | C1                       |
| EEPML-11-08102-1 | 1020X130X88            | 14             | 2275                            | 63kg          |                           | 20A            | C1                       | 440V                      | 10A            | C1                       |
| EEPML-15-15102   | 1020X200X88            | 28             | 4550                            | 101kg         |                           | 33A            | C1                       |                           | 15A            | C1                       |

Custom-Made products (above specification are for reference only)



- Used on Linear Guideway high precision or high accuracy long strip workpiece drilling, grinding machining...etc. (Custom-made)



### Features:

- Structure of Electro-Permanent Magnetic Chuck, 1-3 seconds control for power ON & OFF.  
No electric power supply required to keep the chuck ON.
- EEPML Chucks can be connected and one controller can be control multi-EEPML Chucks.
- Linear guideway/ Long strip workpieces:  
Can be fully clamped by magnetic chuck and increased grinding accuracy.
- It could be used for long time and never get temperatures to affect the accuracy of workpieces.



### Working Example

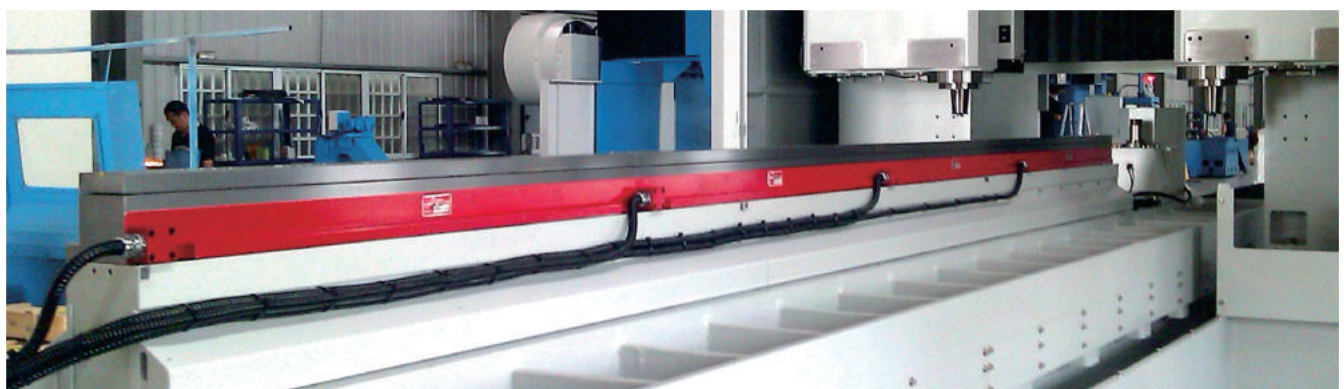
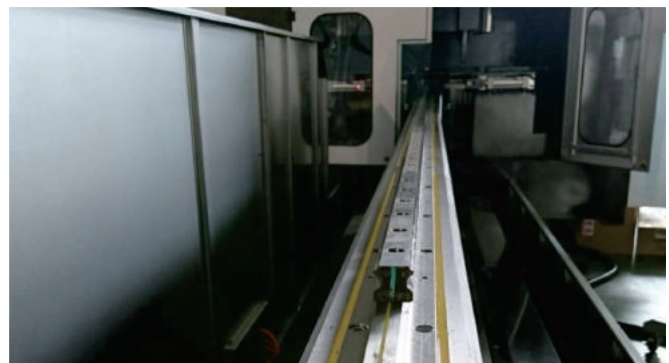
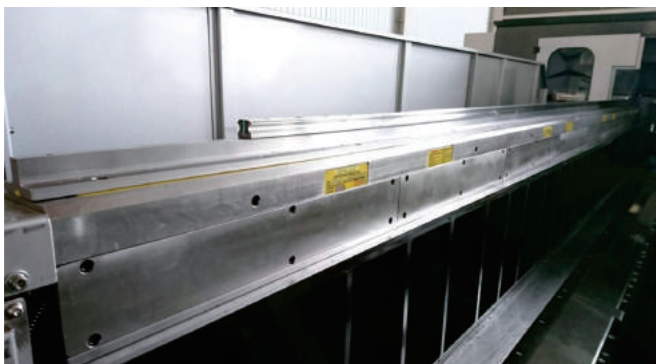



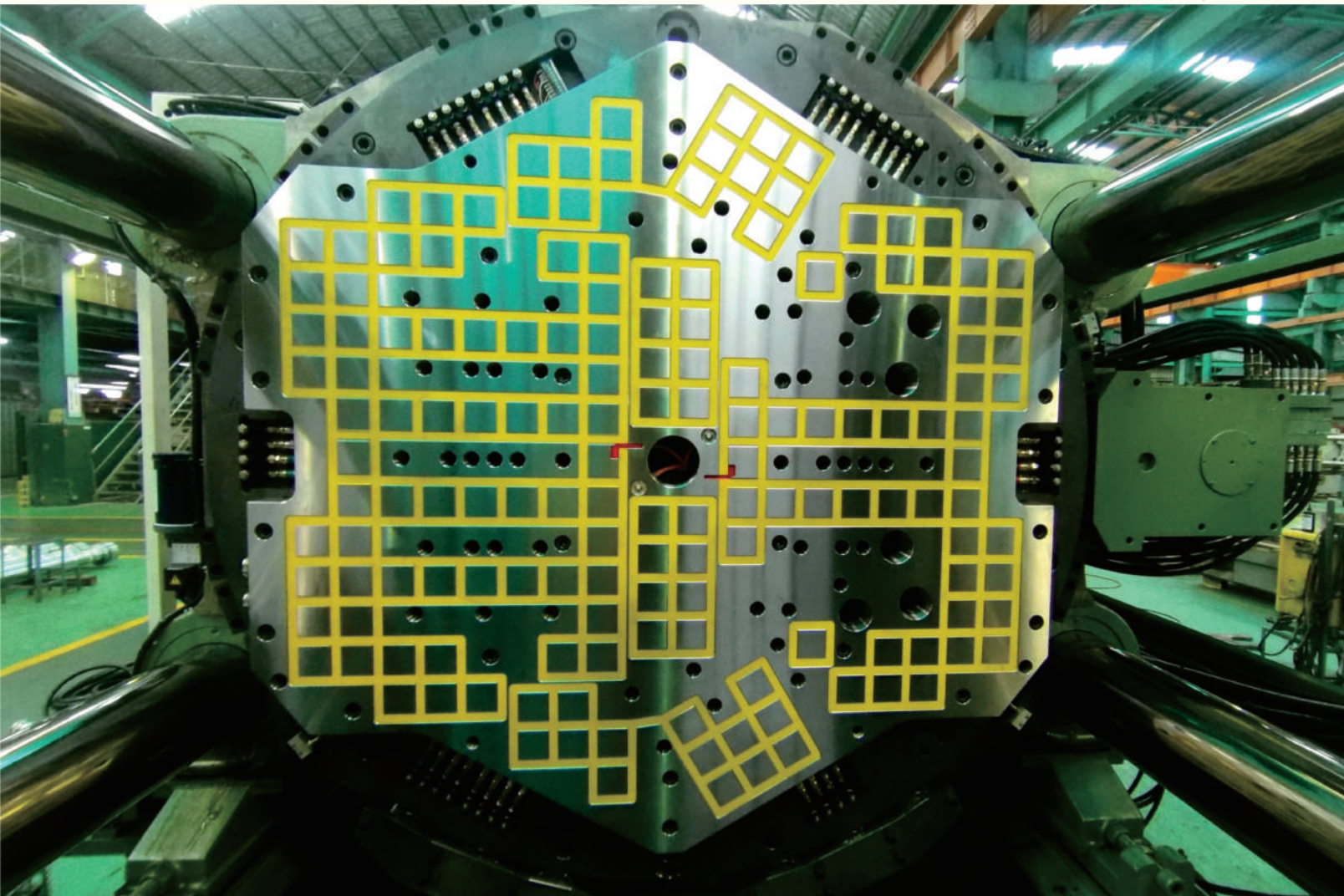

- 1. Safety**
  - Electro-Permanent Magnetic design, no power supply to keep the magnetic chuck ON.
  - Safety in case of power failure. Magnetic power 4~5 times safety factor.
  - Rare-earth material bear up to max. 120°C.
- 2. Humanity**
  - Proximity.
  - IC safety device.
- 3. Quickly**
  - Reduce 70% mold setting time significantly.
  - Shorten delivery time.
- 4. Flexibility**
  - Low cost and high quality.
  - Apply to any kinds of shapes mold.
- 5. Economic**
  - Low labor cost.
  - Low mold repair cost.
  - Less than 1 KW power consuming.
  - Low maintenance cost.
- 6. Improved**
  - Improve machine mold size capacity.
  - Improve machine shifts rotate.
  - Improve quick production demand.
  - Improve production quality
  - Improve strength and parallelism of machine movable/stationary plates and frame.

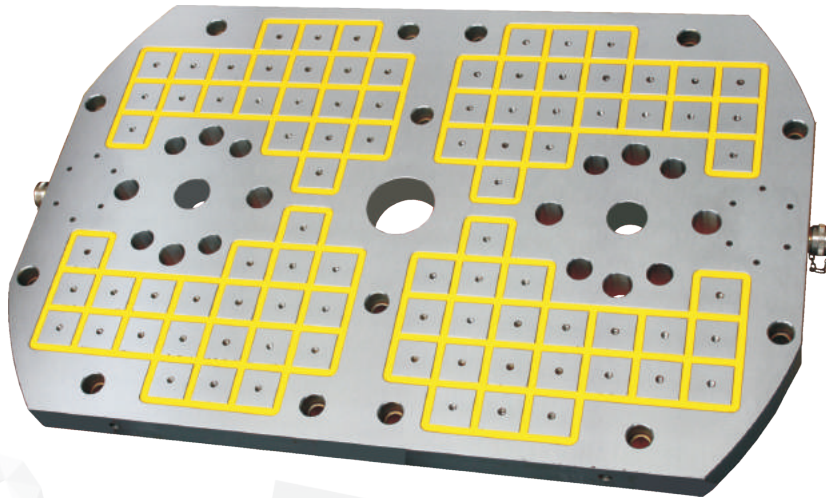

**Features:**

1. Electro-Permanent Magnetic system: 2~10 seconds control for power ON & OFF. No power supply required to keep the magnetic chuck on, Safety in case of power failure. Never get temperatures and deformation mold.
2. Magnetic force depends on the mold needs, with 3 sizes pole can choose.
3. Magnetic chuck is dual poles (N/S poles), no magnetize machine frame and equipment relative parts.
4. The clamping force is distributed consistently along the whole mold surface reduce product burs and increase mold duration.
5. Reduce 70% mold setting time significantly, increase machine shifts, shorten lead times and increase production capacity.
6. Improve the strength and parallelism of machine movable/ stationary plate and machine frame.
7. Increase 20% clamping area, without fixture plate enhancing the performance of the mold.
8. Can be used with a working temperature up to 120°C, higher product safety.
9. No oil working environment, stable quality, applying for high working specification of germfree/dustfree.



**Pole Specification (Height of magnetic field)**

EEPm-PIM designed for different mold thickness. Specify the mold to be Large, Medium and Small sizes, make 3 poles size. Different pole sizes have different magnetic field height to ensure mold clamping safety.

For Small mold

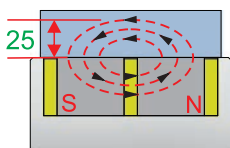

EEPm-PIM Series

For Medium mold

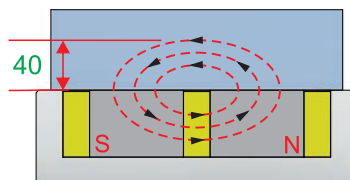

EEPm-PIM-D Series

For Large mold

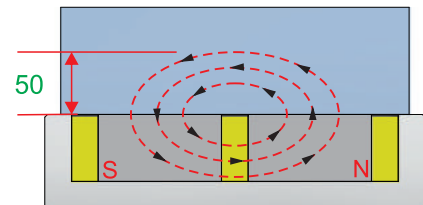

EEPm-PIM-E Series

Unit:mm

| Model No.         | Pole Size | Chuck height | Magnetic field height | Magnetic Force (kgf/ 4 poles) |
|-------------------|-----------|--------------|-----------------------|-------------------------------|
| EEPm-PIM Series   | 50x50     | 60           | 25                    | 1200 ±5%                      |
| EEPm-PIM-D Series | 70x70     | 70           | 40                    | 2800 ±5%                      |
| EEPm-PIM-E Series | 92x92     | 80           | 50                    | 4800 ±5%                      |

\*\* The thickness of EEPm-PIM is available from 35~60 mm, magnetic force is 1100 kgf / 4 poles)



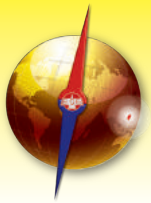

### Human Machine Interface controller upcoming

Human Machine Interface touch screen system, feedback operation status from screen page, and the devices could be driven by pre-set program and parameter. Create new policy of **【MagVise Magnetic Clamping System】** .



### Proximity Sensor Device (Mold clamping detective system)

EEPm-PIM control system built-in IC security detection devices to ensure 100% magnetization when Magnetic Lamp lights on. Install Proximity sensor on the chuck, by detecting lamp shows up the clamping status of the mold, to warn the operator if the mold is completely attached, to avoid holding false happens.

When proximity sensor lamp ON, unable magnetizing process.

When proximity sensor lamp OFF, conduct magnetizing process.

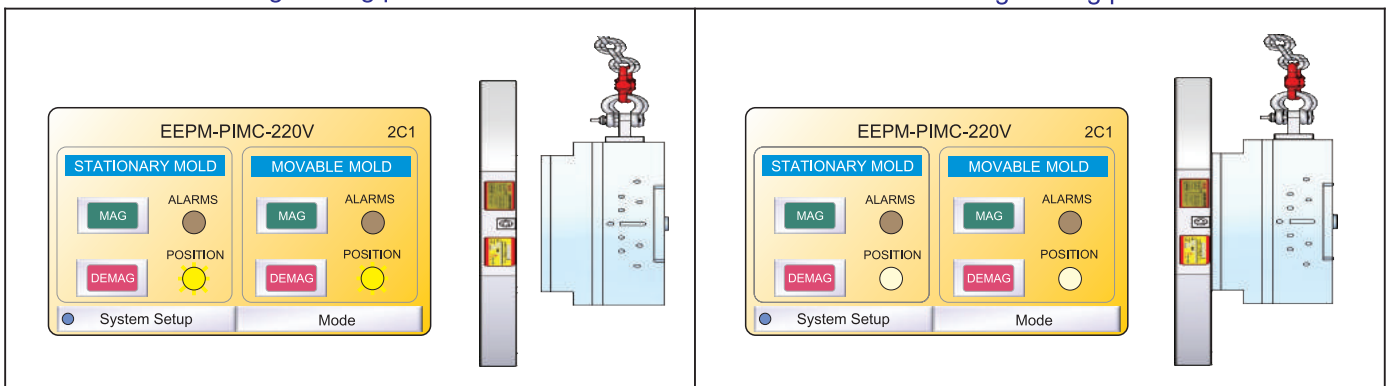

### IC Controller (Safety device)

To ensure operator's safety, EEPm-PIM adds safety device to ensure all set-up process then injection machine starts to production process. Set-up process includes complete mold clamping, complete magnetization, plug chuck cable onto safety device ... etc.

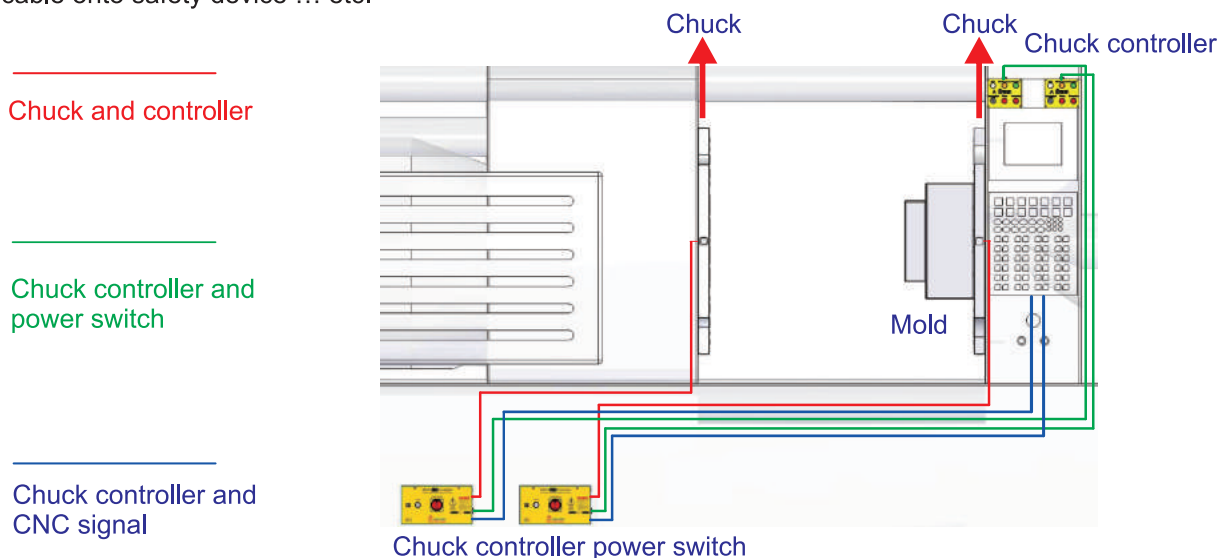

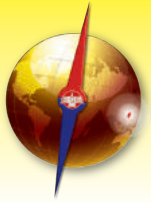

Working Example

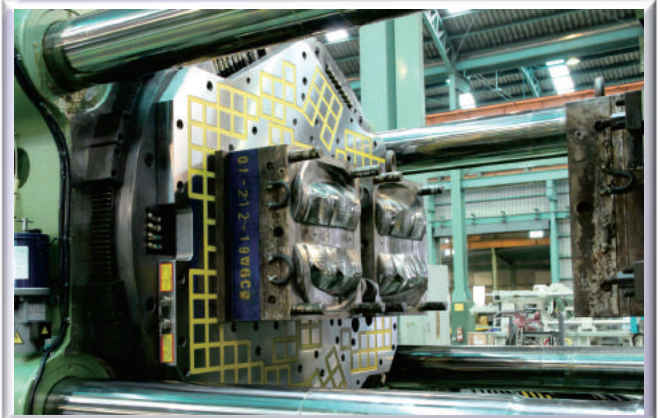
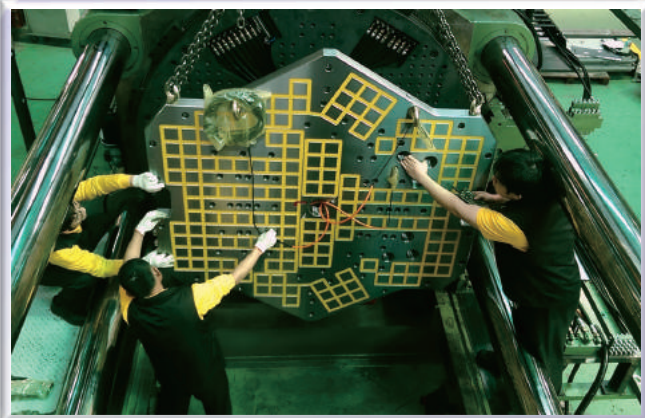
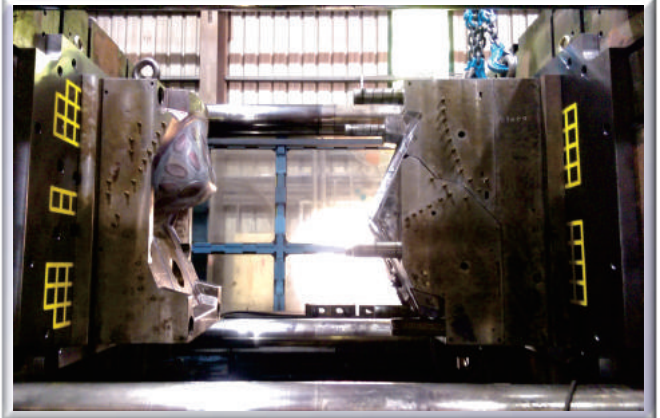
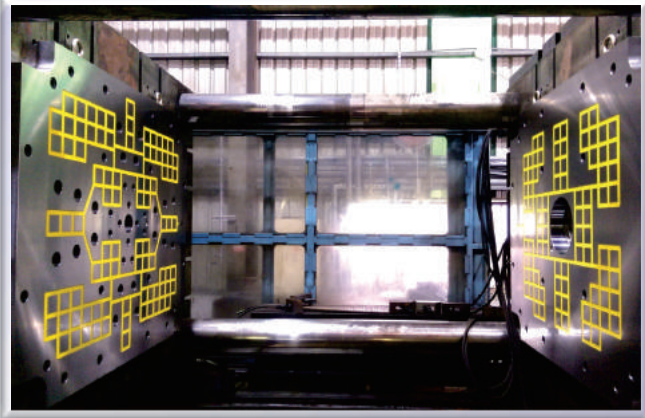
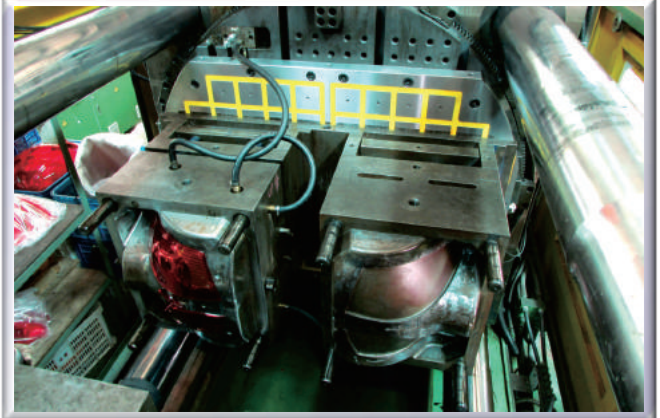
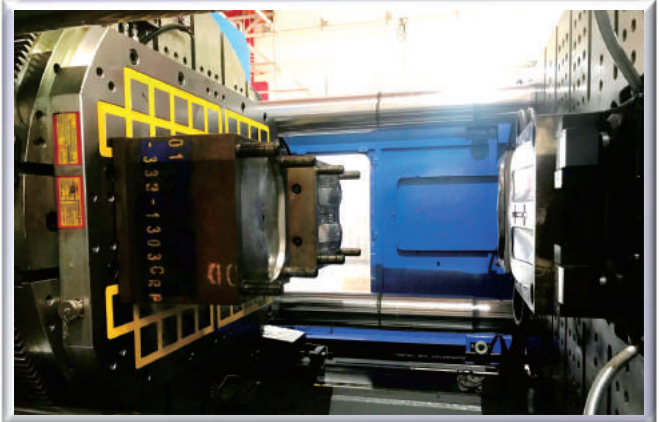
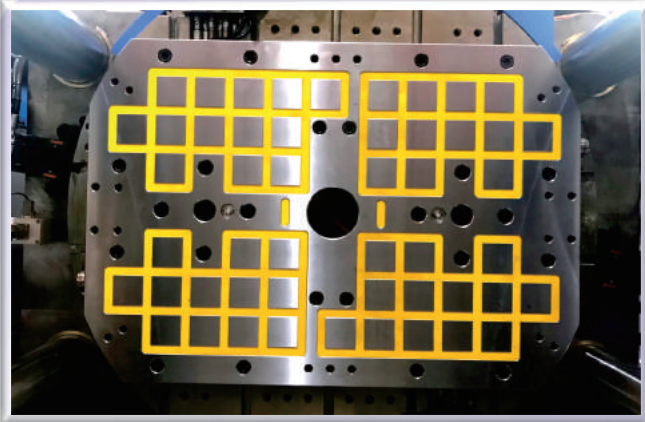



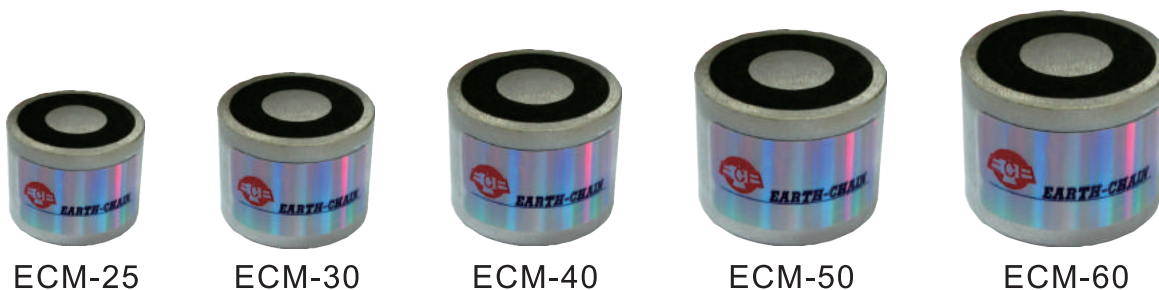
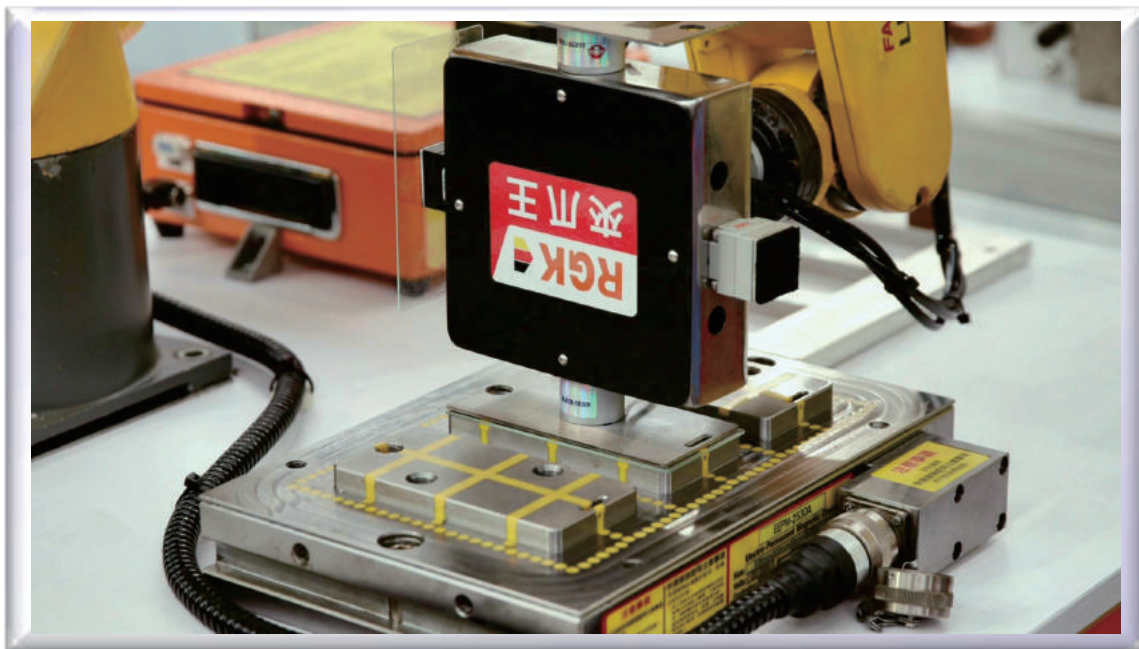
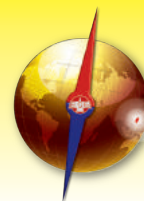

Light weight   Powerful   High Safety   Low Price   Easy assembly



Suitable for automated production line including robotic arm, medical, machine, laboratory equipment and other automatic processing production line materials or product transport applications.

Unit: mm

| MODEL NO. | A  | B  | C  | D  | E    | MAGNETIC FORCE |
|-----------|----|----|----|----|------|----------------|
| ECM-25    | 32 | 15 | M3 | M4 | 22.5 | 15 kgf±5%      |
| ECM-30    | 32 | 18 | M3 | M5 | 24.5 | 25 kgf±5%      |
| ECM-40    | 42 | 26 | M4 | M5 | 30.5 | 60 kgf±5%      |
| ECM-50    | 52 | 34 | M4 | M5 | 34.5 | 90 kgf±5%      |
| ECM-60    | 65 | 40 | M5 | M8 | 38.5 | 160 kgf±5%     |

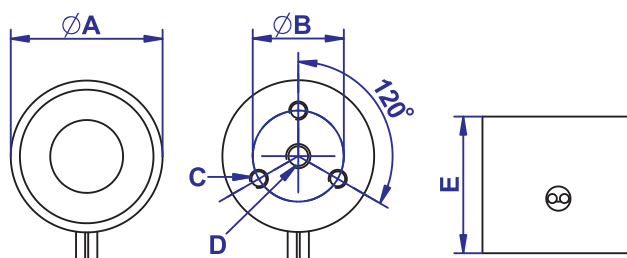

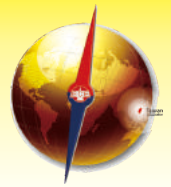

Light weight Powerful High Safety Low Price Easy assembly

Suitable for automated production line including robotic arm, medical, machine, laboratory equipment and other automatic processing production line materials or product transport applications.

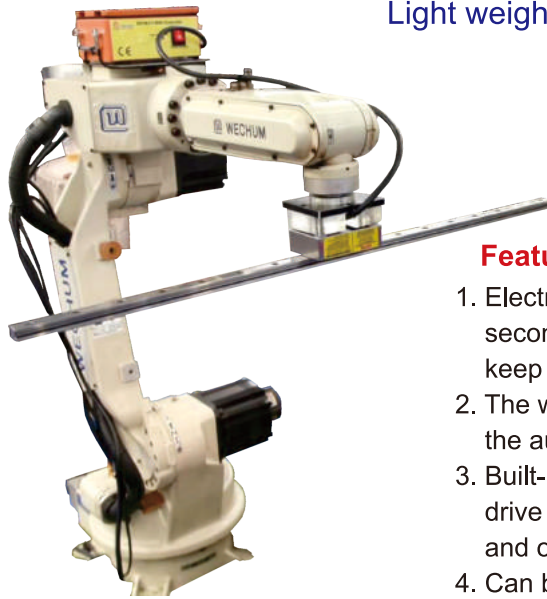

**Features:**

1. Electro-Permanent Magnetic Chuck made by "Neodymium" magnet. One second control for power ON & OFF. No electric power supply required to keep magnetic chuck ON.
2. The workpiece will not fall due to power failure or abnormal status during the automatic transportation.
3. Built-in intelligent IC signal feedback device can be pre-edited program drive integration of other connected device to reduce the manpower time and operational complexity for future industrial applications.
4. Can be used various types of induction block for different workpieces Transportation.

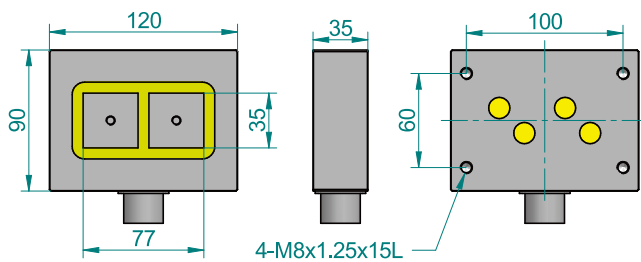

Unit:mm

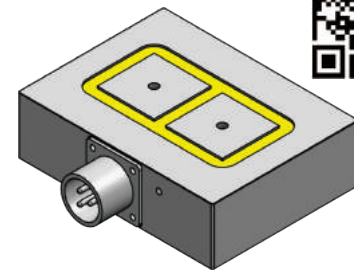

NO. OF POLE:2 TOTAL HOLDING POWER: 290±5% kgf

EPSM-0912A-220V

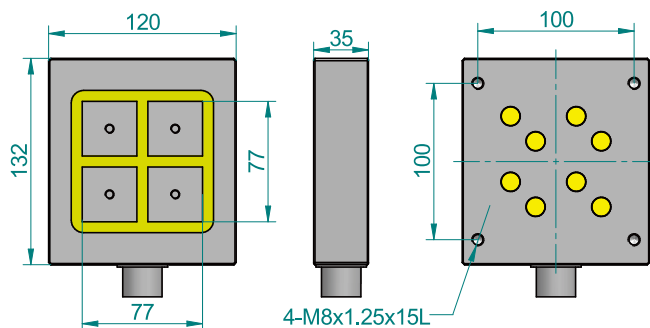

Unit:mm

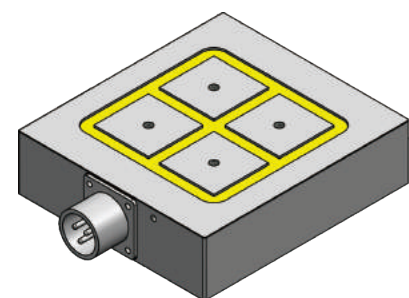

NO. OF POLE:4 TOTAL HOLDING POWER: 580±5% kgf

EPSM-1312A-220V

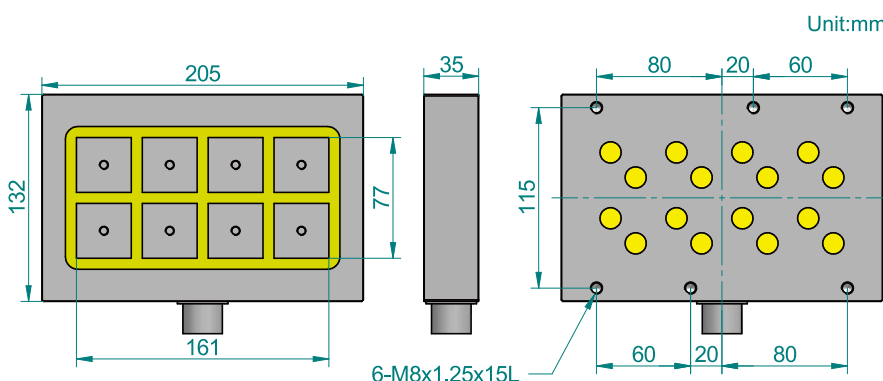

Unit:mm

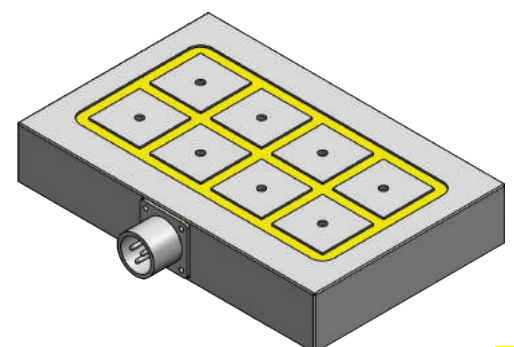

NO. OF POLE:8 TOTAL HOLDING POWER: 1160±5% kgf

EPSM-1320A-220V



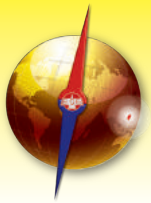

# Mag Vise

## Magnetic Workholding

### Permanent Magnetic Clamping Block ECB Series

■ Suitable for medium & large workpiece. (Can do 5 sides machining).



Patented

Taiwan M258824, Italy / USA us7, 224, 251, B2 / Japan 3106264, / Korea 0366170, / Germany 20 2004 009 776.1 / China L2004 2 0067865.1

#### Standard Accessories

|                            |                        |
|----------------------------|------------------------|
|                            |                        |
| Induction soft block 1 set | Clamping Jaw           |
|                            |                        |
| Handle 1 set               | Guide key 2 pcs        |
|                            |                        |
| Stopping plate 1 set       | Switch connector 1 set |

#### Features:

1. The all new model Magnetic Clamping Block ECB Series are a new sense of clamping way for metal working on CNC Machining Center and Milling Machine in quick clamp workpieces.
2. Free to set up position, numbers and distance of Magnetic Clamping Block according to the size of workpiece.
3. The ECB Series including changeable Induction Soft Block. It can be revised the surface to be 100% accuracy on the machine for clamp workpieces. Can be also cutting, drilling, tapping and slotting directly to the Induction Soft Block during machining workpiece. Multi-function of Induction Soft Block, the user can make it by themselves according to workpiece required.
4. Two machining circle for finish workpiece machining, increase a lot of machining efficiency and achieve accuracy required.

#### Applications:

1. Most suitable for medium and large size of workpiece machining on milling machine and CNC machining center.
2. Minimum size of workpiece required as bigger than an area of two Magnetic Clamping Blocks.
3. The Magnetic Clamping Blocks are not suitable for small workpiece clamping.

#### Note:

1. Please always make sure the Switch was in ON position before machining.
2. The Magnetic Clamping Blocks are not suitable for non-magnetic material, such as brass, copper, aluminum and stainless steel, etc.
3. The principle of Magnetic Clamping Blocks is magnetism of N. S. poles, so please always put the workpiece between N. S. poles.  
(The middle of top clamping range)



#### Working Example

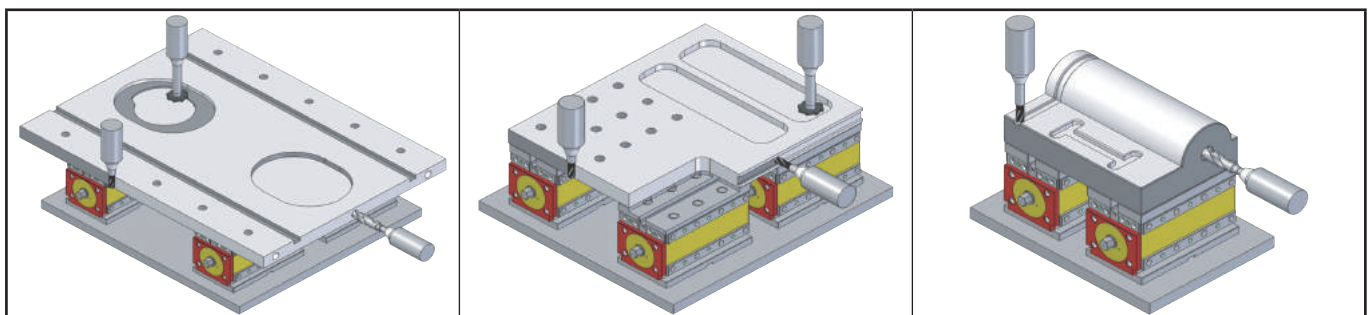

| MODEL NO | HOLDING POWER | MINIMUM THICKNESS OF WORKPIECE REQUIRED | G    | G= +0<br>- 0.03           | H   | H= +0<br>- 0.03           | N.W.  |
|----------|---------------|---|------|---------------------------|-----|---------------------------|-------|
| ECB-210  | 2100kgf±5%    | 30                                      | 115  | Accuracy control required | 134 | Accuracy control required | 36kg  |
| ECB-120  | 1200kgf±5%    | 20                                      | 92.5 |                           | 108 |                           | 18kg  |
| ECB-075  | 750kgf±5%     | 15                                      | 85   |                           | 78  |                           | 9.5kg |
| ECB-050  | 500kgf±5%     | 15                                      | 61   |                           | 78  |                           | 7kg   |

Continual to next page.



**Dimension ECB-210**

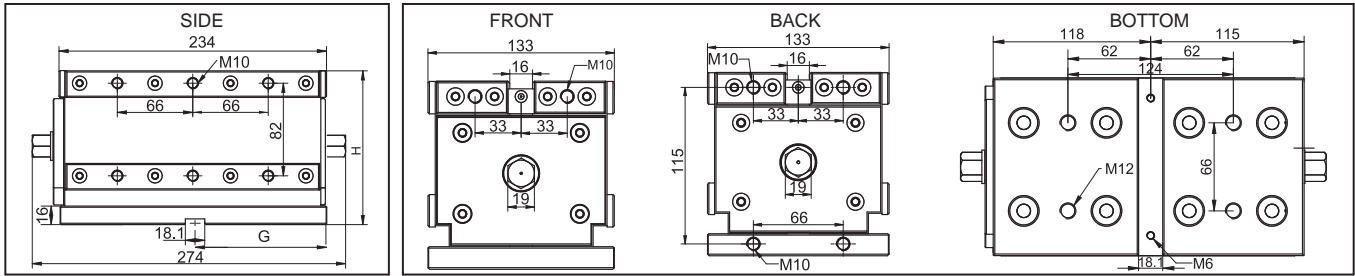

**ECB-120**

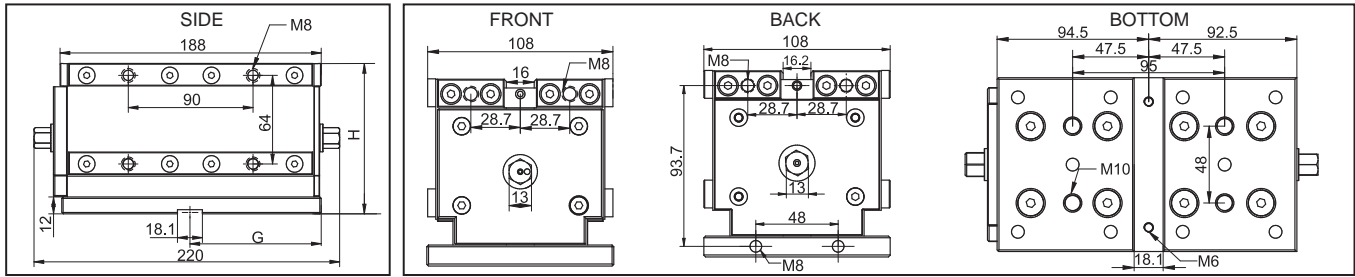

**ECB-075**

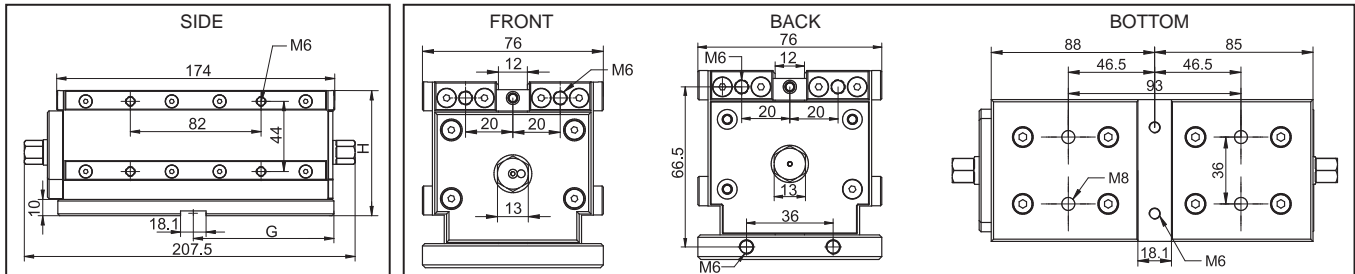

**ECB-050**

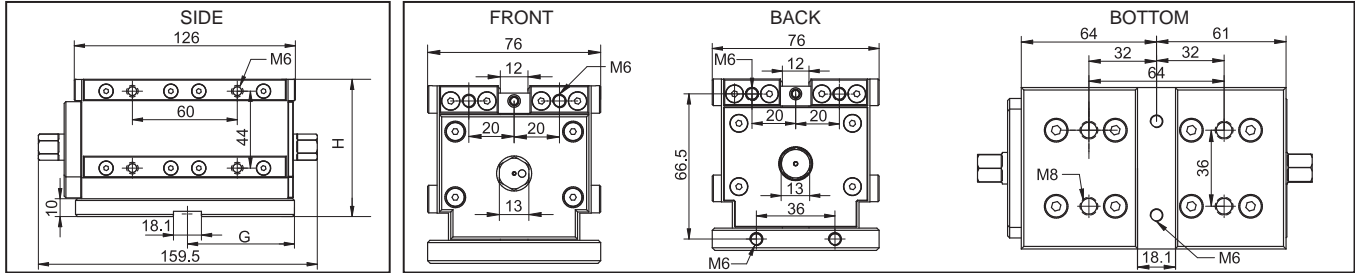

**Accuracy Control**

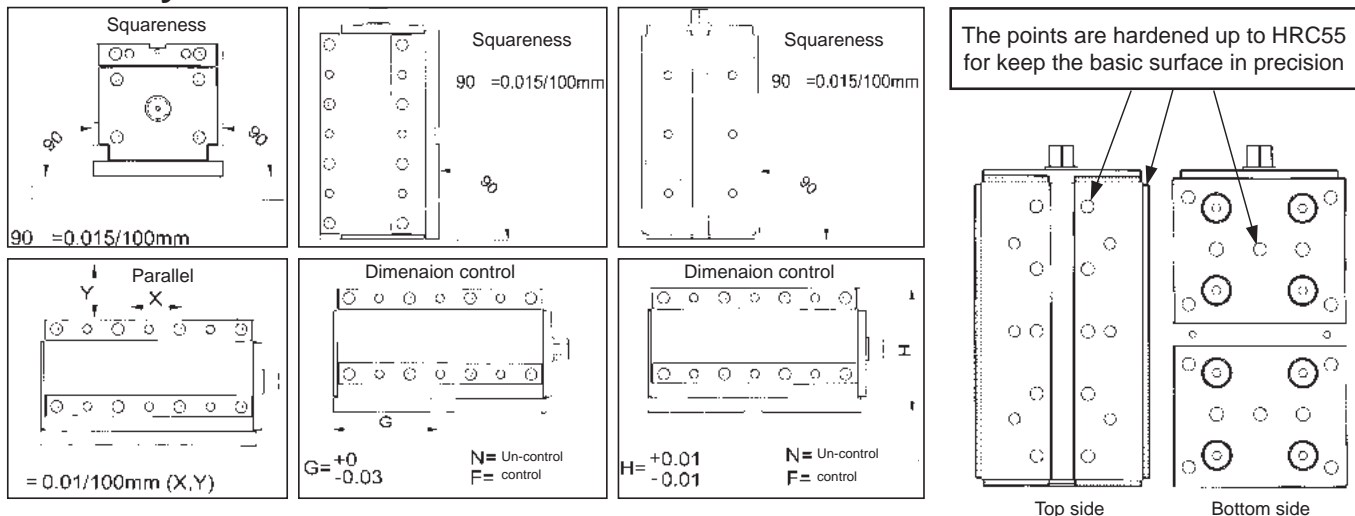



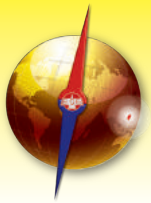

# Mag Vise

## Permanent Magnetic Clamping Block ECB Series

### Magnetic Workholding

■ Suitable for medium & large workpiece. (Can do 5 sides machining).

Customer can be makes switch connector by standard hexagon steel bar themselves for depends on length required. The dimension of hexagon bar required as ECB-210 --- 19mm,

ECB-120, 075, 050 --- 13mm.



Maximum & Minimum distance required

Unit:mm

| MODEL NO              |      | ECB-210 | ECB-120 | ECB-075 | ECB-050 |
|-----------------------|------|---------|---------|---------|---------|
| SIDE DISTANCE         | Min. | 100     | 60      | 25      | 25      |
|                       | Max. | 1000    | 600     | 400     | 400     |
| FRONT & BACK DISTANCE | Min. | 70      | 40      | 40      | 40      |
|                       | Max. | 500     | 300     | 200     | 200     |

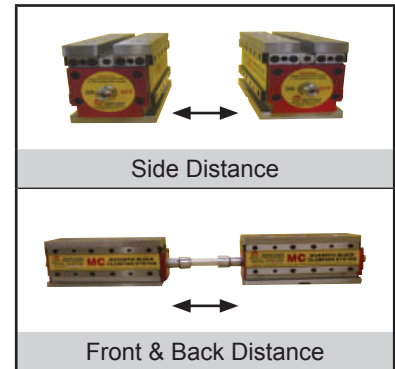

### Special made Induction Block:

Customer can makes special induction block themselves for depends on the workpiece and application required.

(The material of induction block required as general and low carbon steel)

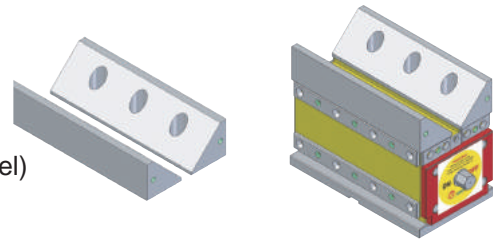

### Example

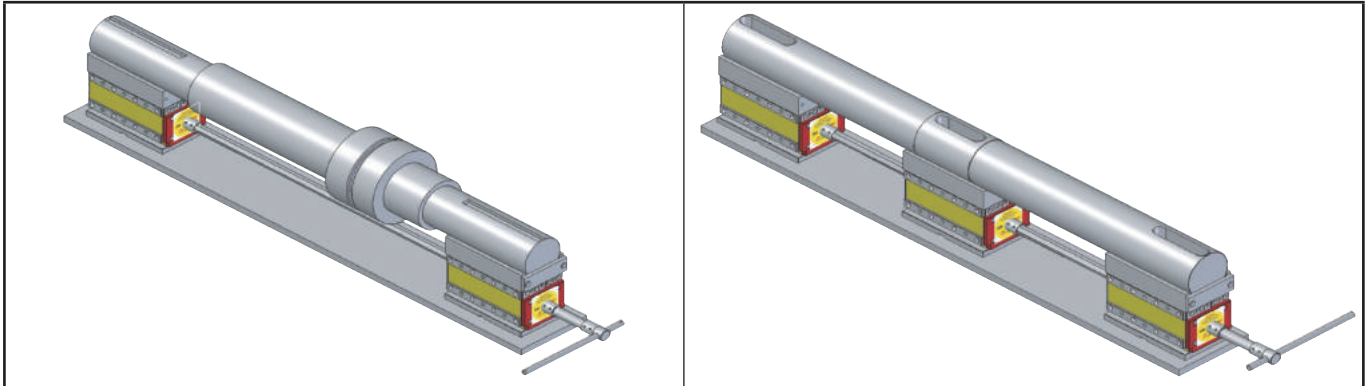

### Working Example





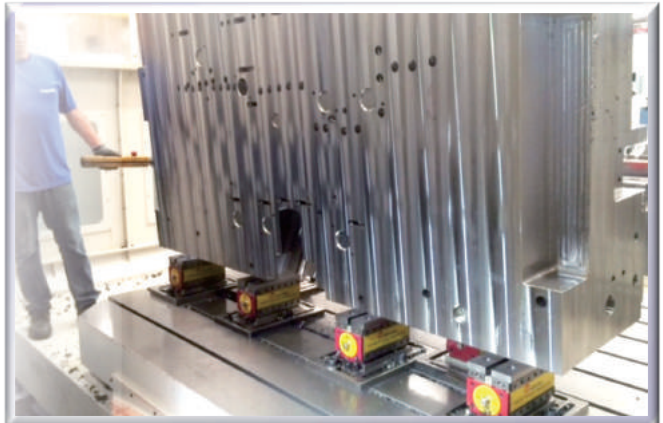
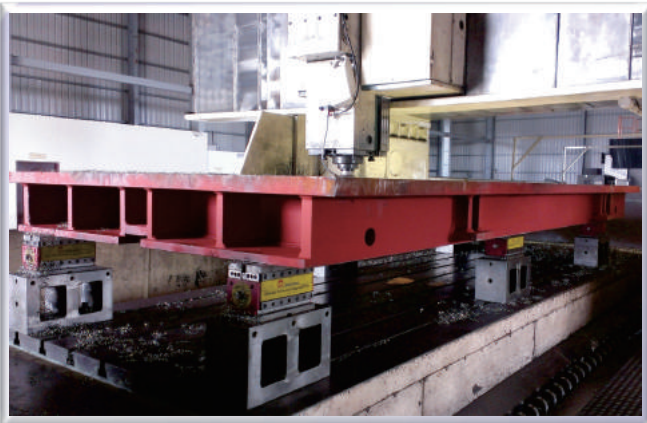
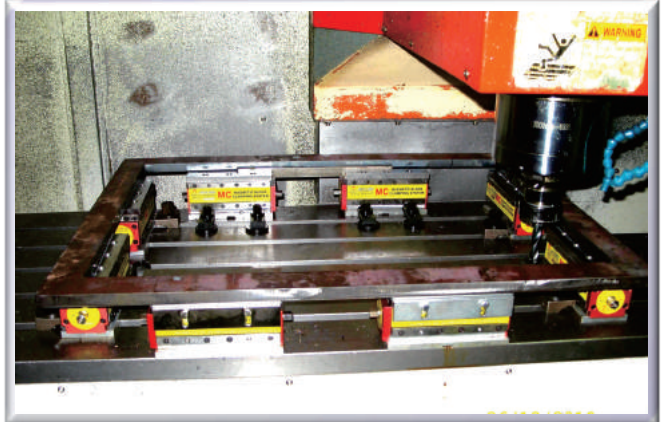
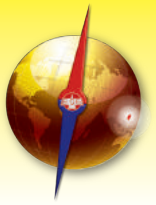



# Mag Vise

Magnetic Workholding

## Permanent Magnetic Clamping Block ECB Series

■ Suitable for medium & large workpiece. (Can do 5 sides machining).

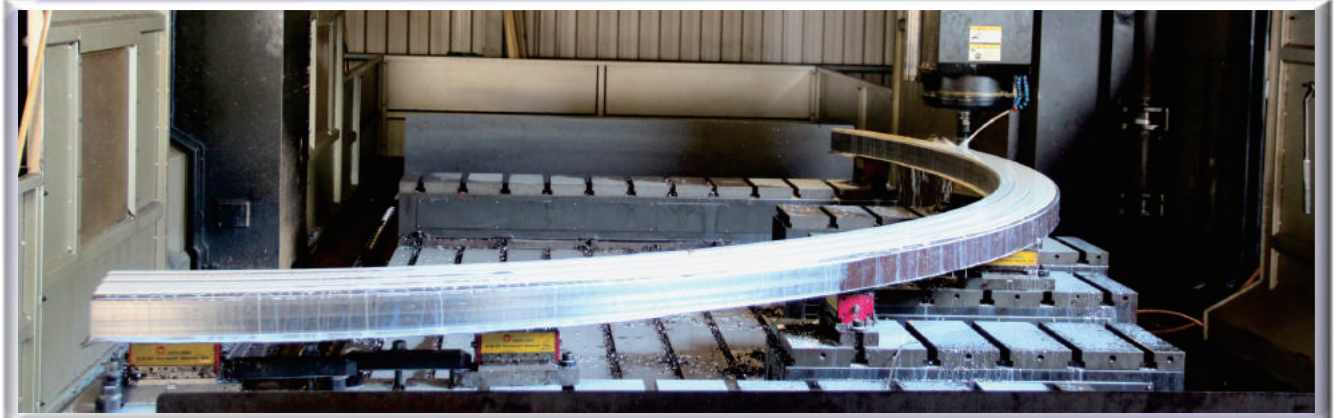
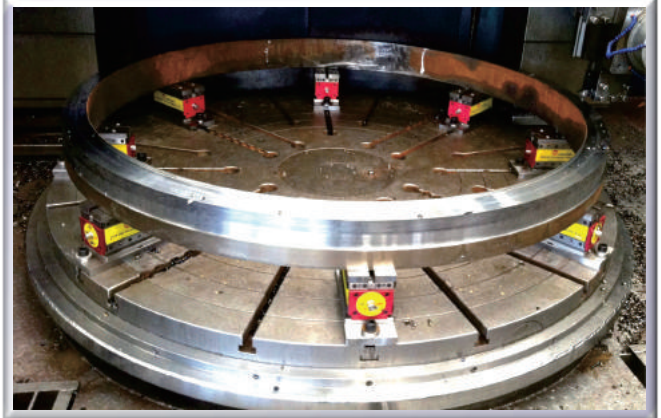
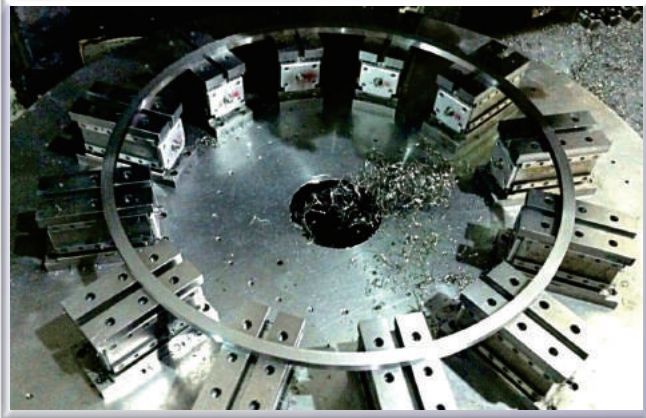
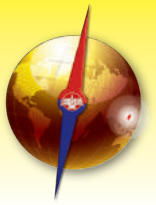



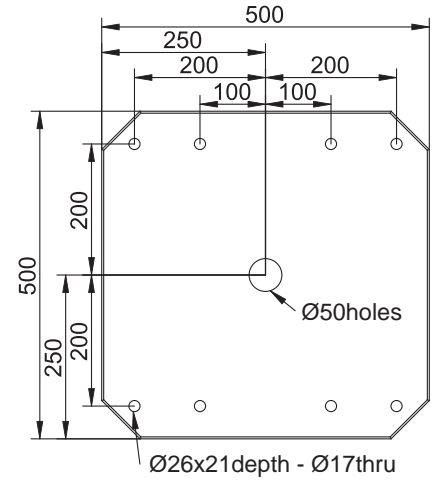
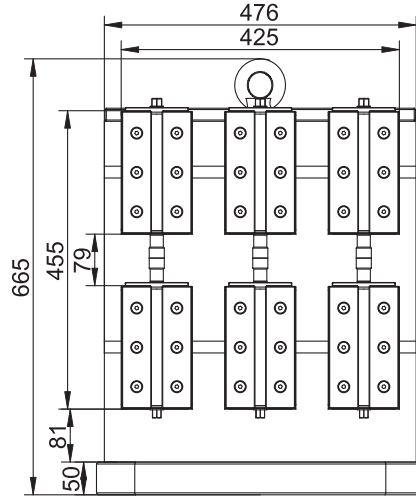
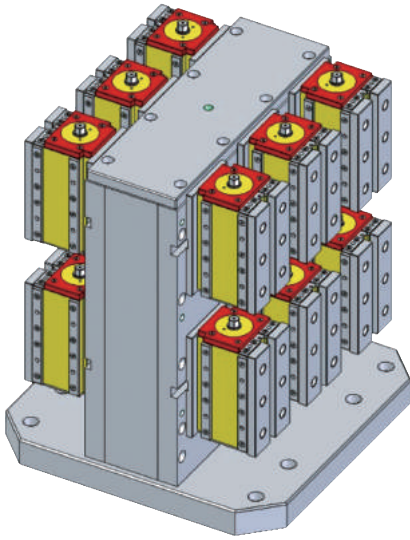

**Features & Applications:**

1. Each 6pcs of ECB-120 magnetic clamping block on 2 working face, each of 7200 kgf  $\pm 5\%$  (1200kgf $\times 6$ ) holding power, can be clamping 2 big workpieces for machining at same time.
2. Customer can makes and assemble any type of clamping device themselves by ECB series for depends on workpieces required.
3. Suitable for use on CNC Horizontal Machining Center. (can do 5 sides machining.)

**Working Example**







## ANTARCTIC ARCTIC ZERO

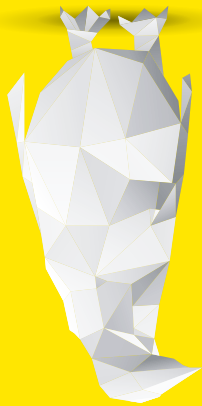

### Mag Vise Magnetic Workholding

CNC Vertical/ Horizontal Machining Center  
CNC Vertical/Horizontal Turning Lathes  
Double Column Vertical Machining Center  
CNC 4/5 Axis Machining Center

Quick Mold Change Systems for  
Plastic Injection Machine  
Lifting Magnet Series  
Universal Arm Magnetic Stand

