

Hi-TECH 230

8-10" Chucker Box Way Type
Horizontal Turning Center



Contents

Product Overview

Basic Information

- Basic Structure ————— 04
- Cutting Performance ————— 07

Detailed Information

- Standard / Optional Accessories Status — 08
- Hwacheon Software ————— 11
- Diagram ————— 12
- Machine / NC Specifications ————— 18

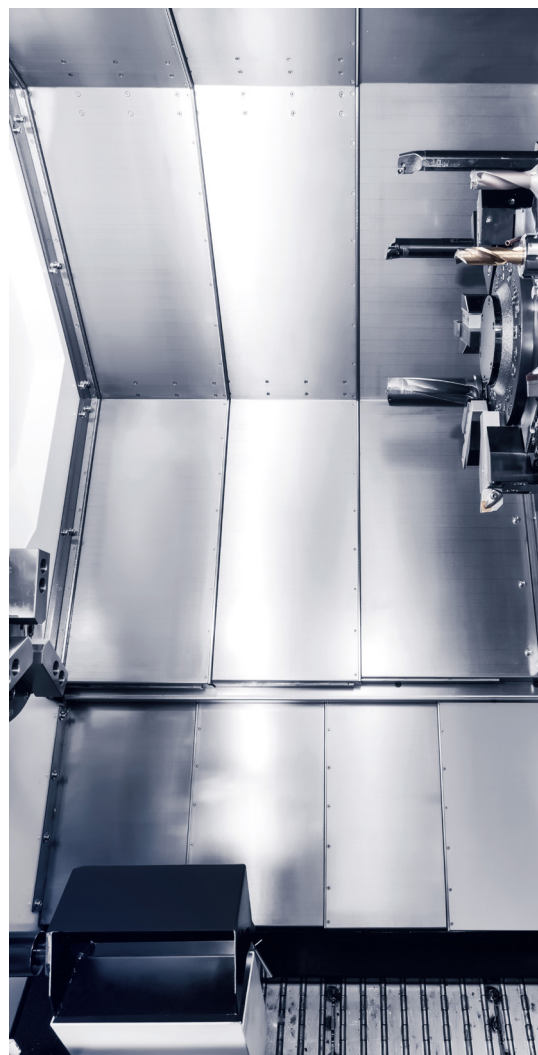

New Standard for 8-10" Lathe Faithful to the Basics

Hi-TECH 230 provides more reliable machining performance based on excellent machine rigidity and upgraded specifications compared to the existing 8-10" lathes with box-way structure, and provides greatly enhanced user convenience and maintainability. The Y-axis model has Y-axis stroke of up to ± 60 mm (± 2.36 inch), the largest in class.



Upgrades for Enhanced Machining Performance

- 1 Enhanced feed system rigidity for X and Y axes
- 2 Enhanced machine structure rigidity
- 3 Upgraded main spindle motor
- 4 The highest turnmill motor power in class
- 5 Extended max. bar diameter
- 6 Possible to apply the 24 positions index turret

Enhanced User Convenience

- 1 Lighter door to ease the operator's tiredness
- 2 Structure to prevent chip accumulation in the door bottom
- 3 90° rotating operator panel
- 4 Optional software for user convenience (Operating and machining)

Easy Maintenance

- 1 Coolant tank placed at the front and easy to remove
- 2 Coolant level sensor applied as standard
- 3 Use of external coolant block prevents the leakage of turret inside

Basic Information

Basic Structure

"Increased Structural Rigidity of the Machine"
via FEM Analysis

The cutting area and the feed zone are separated to
"Minimize Thermal Displacement of the Frame"
caused by hot chips and coolant

"Slanted Bed Structure"
for easy chip disposal

"The Largest Cutting Area in Class"

Max Cutting Dia **Ø425 mm (Ø16.73 inch)**

Max Cutting Length **633 mm (24.92 inch)**

* Based on Hi-TECH 230AL STD

Type	Chuck Size inch	Max Stroke mm (inch)			Rapid Speed m/min (ipm)		
		X-axis	Z-axis	Y-axis	X-axis	Z-axis	Y-axis
Hi-TECH 230A(L)	8						
Hi-TECH 230B(L)	10	240 (9.45)	460 (18.11) L:700 (27.56)	±60 (±2.36)	30 (1,181)	30 (1,181)	10 (393.7)
Hi-TECH 230C(L)							

* Y-axis is Y(S)MC Type Only.

Y-axis Machining

The largest Y-axis stroke in class

"Maximized Y-axis Machining Performance"

Finishing using Y-axis

Multi-face machining

Milling at the position deviated from the center

Circular interpolation for X and Y axes

Ys-axis

X-axis

Y-axis

60 mm (2.36 inch)

60 mm (2.36 inch)

Slanted Bed

Type	Y-axis Stroke mm (inch)	Y-axis Rapid Speed m/min (ipm)	Inclination Angle (deg)		
			Slanted Bed	X-axis	X-Ys axis
Hi-TECH 230 SERIES Y(S)MC	±60 (±2.36)	10 (393.7)		30	

Main Spindle

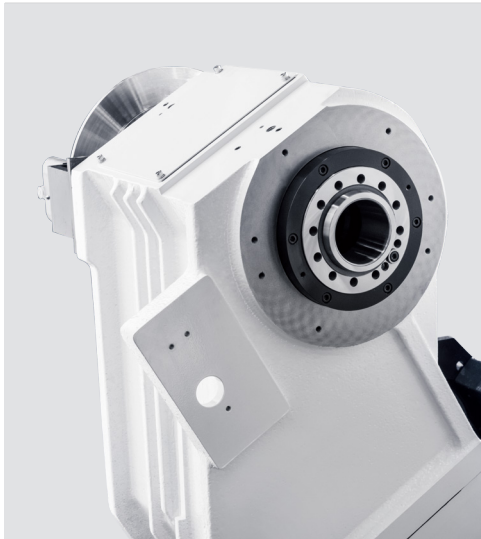

Enhanced high-power motor compared to existing 8-10" lathes
"Enhanced Cutting Performance and Productivity"

Max Spindle Speed **4,500 rpm**

Spindle Motor **18.5 kW**
 * Based on Hi-TECH 230A



Minimized equipment installation space and placed the main spindle motor in a way to ensure easy application of the bar feeder

Type	Max Spindle Speed rpm	Spindle Motor kW (HP)	Spindle Torque Nm	Max Bar Size mm (inch)	Type of Spindle Nose ASA
Hi-TECH 230 A	4,500	18.5 / 15 (25 / 20)	330	Ø65 (Ø2.56)	A2-6
Hi-TECH 230 B	3,500		410	Ø81 (Ø3.19)	
Hi-TECH 230 C		22/18.5 (30 / 25)	700		A2-8

Tailstock

Its digital tailstock (hydraulic) makes setting materials convenient and implements fast cycle time as its setting time is shorter than that of a conventional equipment

"Setting Time Reduced by 70% or More"

* Comparison of tailstock setting times when the 200 mm (7.87 inch) material is used

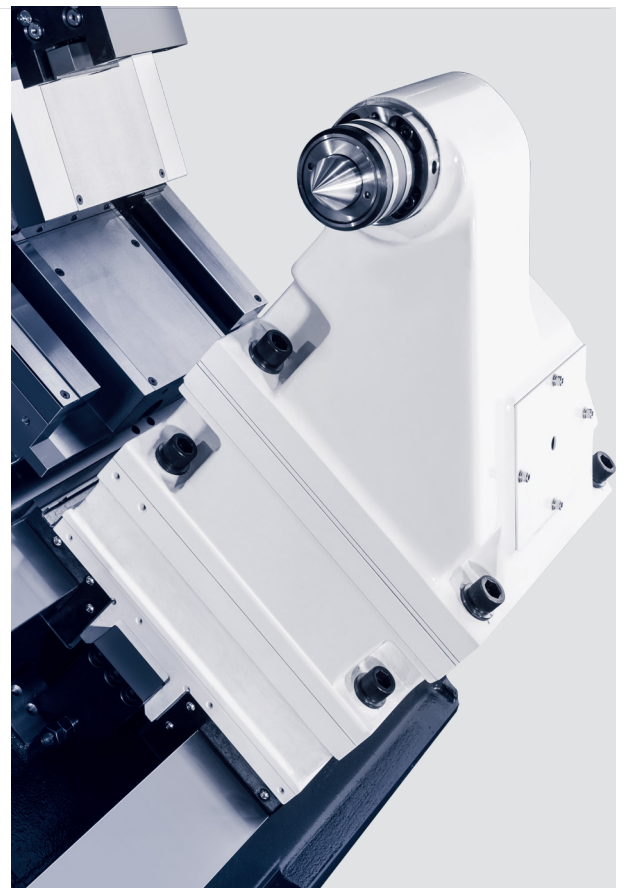

Type	Max Stroke mm (inch)	Cylinder Dia mm (inch)	Center Taper MT
Hi-TECH 230A(L)	460 (18.11) [L:700 (27.56)]	Ø50 (Ø1.97)	#5
Hi-TECH 230B(L)	410 (16.14) [L:645 (25.39)]		
Hi-TECH 230C(L)			

Basic Information

Turret

- 1 Its external coolant block prevents leakage (cause of failure) of turret inside from the source.
- 2 The largest turnmill motor in class : **5.5 / 3.7 kW**
- 3 Extended turret disk width
 - Standard model: The disk width extended by **25%** compared to the existing model
 - MC model: **BMT55** applied
- 4 Enhanced turret rigidity : The reduced distance between the disk and the curvic coupling decreases the moment imposed on the curvic by **24%**.
- 5 Possible to apply 24 positions index turret



·Double O.D Holder



·Double I.D Holder

Type	Number of Tool Stations	Tool Size mm (inch)	Turret Indexing Time sec/step	Max Speed of Rotating Tool rpm	Disk Width mm (inch)
STD	12	O.D: □25 (□0.98)	0.344	-	100 (3.94)
MC	12 (24 Positions Index)	I.D: Ø40 (Ø1.57)		5,000	

*The turret indexing time is the individual time based on 12 stations.

Feed System

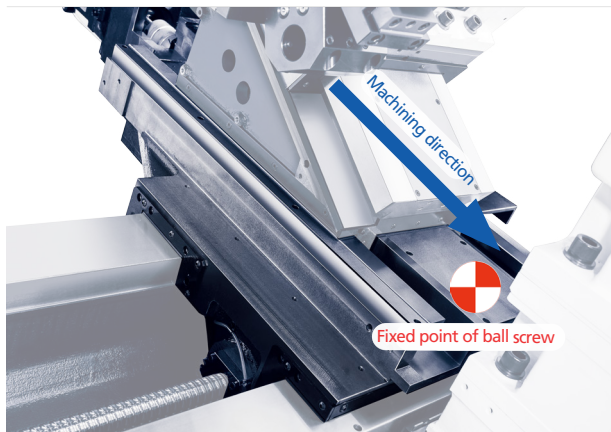

Changed fixed point of X-axis ball screw to minimize the machining error.

"Minimized Machining Error Caused by Thermal Displacement"

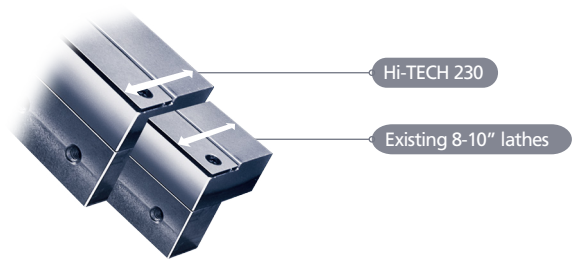

The guide way contact area is increased by 40%.

"Reinforced Feed System Rigidity"

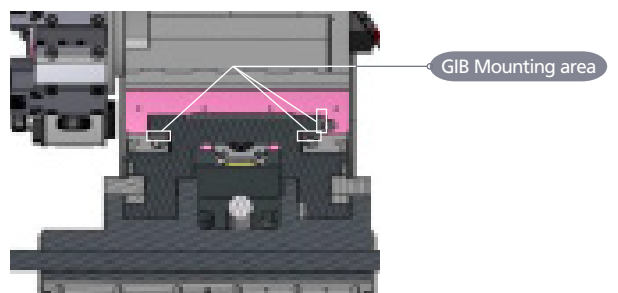

"Easy Precision Control Using GIB"

Cutting Performance

Material : Carbon Steel (SM45C)

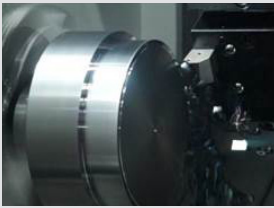

O.D Cutting					
Material Dia mm (inch)	Cutting Speed m/min (ipm)	Feed mm/rev	Spindle Speed rpm	Cutting Depth mm (inch)	Material Removal Rate cm ³ /min
182 (7.17)	220 (8,661)	0.27	421	6 (0.24)	356.4

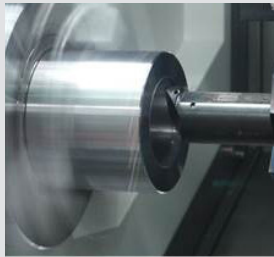

I.D Cutting					
Process	Material Dia mm (inch)	Cutting Speed m/min (ipm)	Feed mm/rev	Spindle Speed rpm	Cutting Depth mm (inch)
Finishing	70.1 (2.76)	150 (5,905)	0.1	680	0.1 (0.004)
Roughing	72.5 (2.85)	100 (3,937)	0.34	428	1 (0.04)

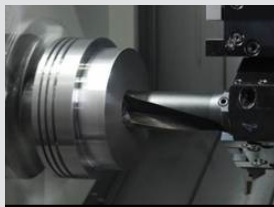

U-Drill					
Tool Dia mm (inch)	Cutting Speed m/min (ipm)	Feed mm/rev	Spindle Speed rpm	Cutting Depth mm (inch)	Material Removal Rate cm ³ /min
55 (2.17)	120 (4,724)	0.18	694	50 (1.97)	297



Groove			
Cutting Speed m/min (ipm)	Insert Width mm (inch)	Feed mm/rev	Material Removal Rate cm ³ /min
150 (5,905)	5 (0.2)	0.25	187.5



Turnmill Drill				
Cutting Speed m/min (ipm)	Feed mm/rev	Spindle Speed rpm	Cutting Depth mm (inch)	Material Removal Rate cm ³ /min
30 (1,181)	0.1	478	30 (1.18)	15



Turnmill Tap					
Process	Tap Size	Cutting Speed m/min (ipm)	Feed mm/rev	Spindle Speed rpm	Tapping Depth mm (inch)
Axial (Z-axis)	M16	30 (1,181)	2.0	597	25 (0.98)



Face Cutter					
Tool Dia mm (inch)	Cutting Speed m/min (ipm)	Feed mm/rev	Spindle Speed rpm	Cutting Depth mm (inch)	Material Removal Rate cm ³ /min
63 (2.48)	198 (7,795)	300	1,000	4 (0.16)	75.6

* The machining results above are examples based on the factory test standards, and are subjected to the changes in conditions.



Parts Catcher (OPT)

Thanks to its simple structure, the parts catcher is easy to attach / detach and it is possible to implement simplified automation if used with the bar feeder at the same time.

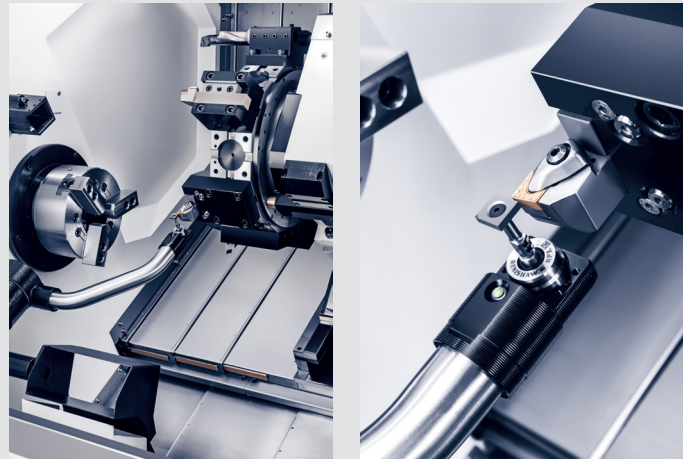

Tool Presetter (OPT)

Available functions with automatic tool presetter

- With a simple touch on the sensor, it perfectly sets the coordinate system (within 15 seconds per tool).
- The tool shape error value is automatically calculated and entered.
- The automatic coordinate system is promptly configured according to the material geometry.

Automatic Coolant System (STD)

External Coolant Tank

A coolant tank is placed at the front of the machine for easy coolant exchange as well as easy tank cleaning and pump maintenance. Particularly, it is possible to separate the tank only without removing the chip conveyor for easy tank cleaning.

Mesh Chip Filter

A 3-layered mesh chip filter, which is able to sort from long chips to micro chips, extends the service life of the coolant pump.

Various Options

- Standard Coolant Pump : 0.05 MPa
- Optional Coolant Pump
→ 0.6 / 1.5 / 3 / 7 MPa
- Oil Skimmer (OPT)
- Lift-up Chip Conveyor :
Hinge / Scraper Type (OPT)

Tank Capacity

Short Type : 160 ℓ (42.27 gal)
Long Type : 175 ℓ (46.23 gal)

Power

0.4 kW (for Turret)

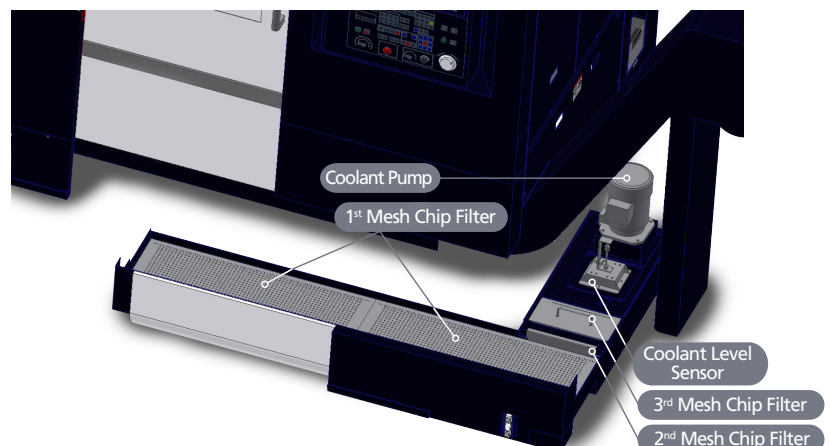

• Detailed Information

Convenient Operator Panel

90° Rotating Operator Panel (STD)



The operator panel is newly designed from the operator's viewpoint and thus enhances the operator's convenience

"User Friendly Design"

- 10.4" display as standard (USB and PCMCIA cards as standard)
- Enhanced operability by optimizing the layout and improving the touch feeling of control buttons.
- Horizontal keys enhance user convenience.
- Long time continuous DNC operation with the CF card even without the data server.

Machine Optimization (STD)

- The cycle machining as well as the operating time and the acceleration / deceleration speed of feed system are optimized.
- Dramatically reduced non-cutting time during machining ensures optimal productivity.
- High precision, speed and smoothness are realized using the cutting-edge machining technology.
- Machining surface quality enhanced by HRV+ control. (HRV+: effectively prevents machine oscillation by controlling the servo current to enhance the machining surface quality.)

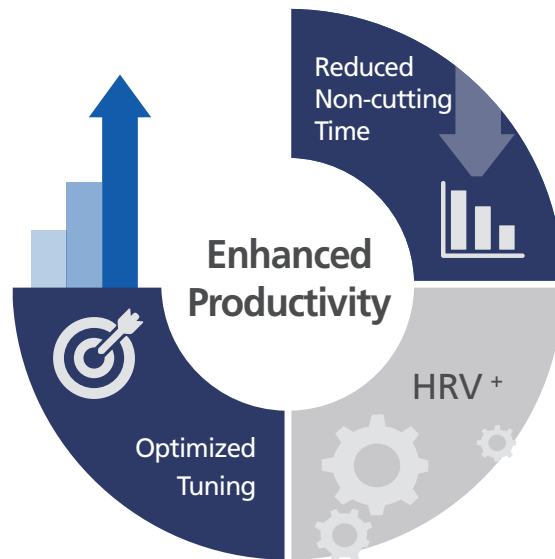

"Enhanced Productivity"

Hwacheon Software

It monitors the load factors of spindles and each axis during lathe (turnmill) machining and provides the following benefits to customers

1. Tool life management

- Generates an alarm for excessive insert wear (overload)

2. Optimized process

- Able to control individual machining conditions per insert wear

3. Able to quickly respond to wear and damage of tools

- Generates a replacement alarm in the event of an insert damage

You can monitor the daily / total production quantity and tool usages.

The number of machining parts
The number of required parts (entered by the user)
Total number of machining parts

Reset the number of machining parts

Reset the total number of machining parts

Reset the current tool counter (NOW)

Tool Count Management : 8 tools

- Display the current tool counter (NOW)
- Notify tool replacement via alarm (SET)
- Inform tool replacement in advance via message (ADV)
- The rate (RATE) of the current usage value (NOW) to the tool replacement target value (SET)

Lathe Hwacheon Tool Load Detect System (OPT)

L-HTLD

Lathe Hwacheon Tool Load Detect system

L-COUNT

Lathe Work / Tool Counter Management

Work / Tool Counter Management (OPT)

Lathe Calculator Function (OPT)

L-CAL

Lathe Calculator Function

L-WCMP

Lathe Workpiece Clamp of Chuck

Workpiece Clamp of Chuck (OPT)

You can enter values required for machining directly from the display control panel for an easy calculation without a calculator

- The number of optimal main spindle speed
- The cutting speed
- Material removal rate (MRR)
- The cutting time

To complement the drawback of the proximity switch of which the position should be adjusted according to the material diameter, the analog sensor (0-10V) is used to set the distances of the open and close zones from the operating screen for enhanced user convenience. (However, it is necessary to discuss with factory in advance whether it is possible to mount the analog sensor.)

- View the chuck open / close state
- Change the driving condition according to the chuck type (inner and outer diameters)
- Set the chuck open / close zone
- An alarm is generated if the chuck function fails

• Detailed Information

Machine Size

Ⓢ Short Type Ⓛ Long Type

* Unit : mm (inch)

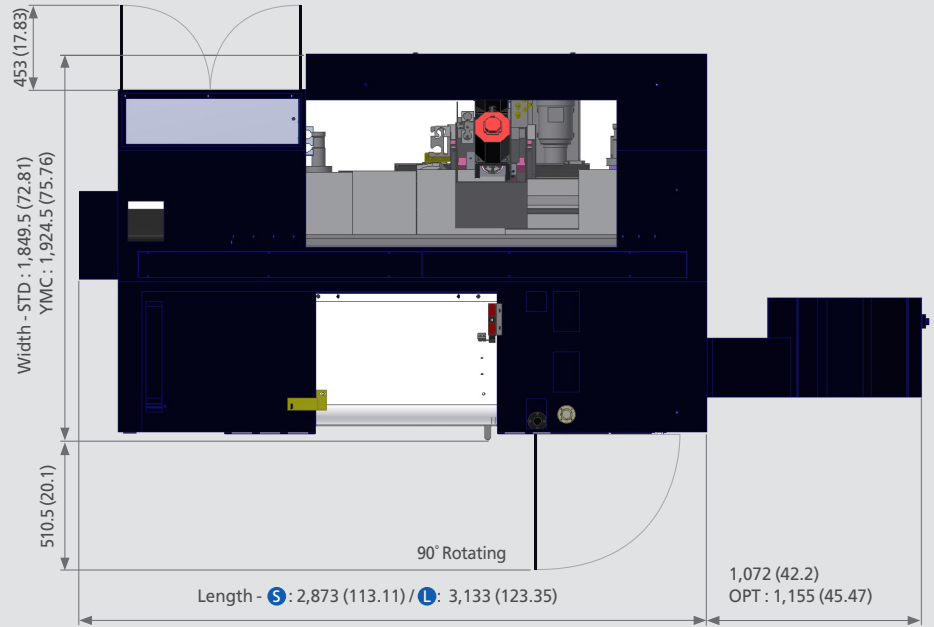

Top

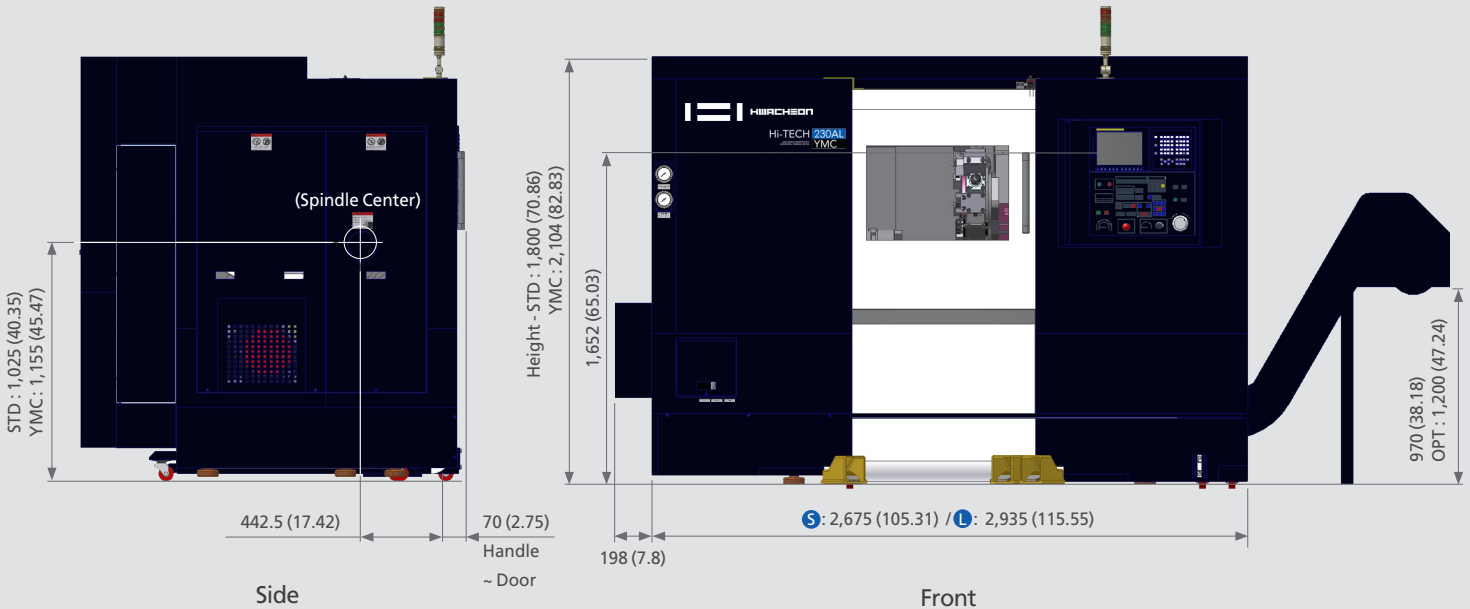

Spindle Power – Torque Diagram

4,500 rpm (Hi-TECH230A)

Max Power : 18.5 kW (25 HP) / Max Torque : 330 Nm

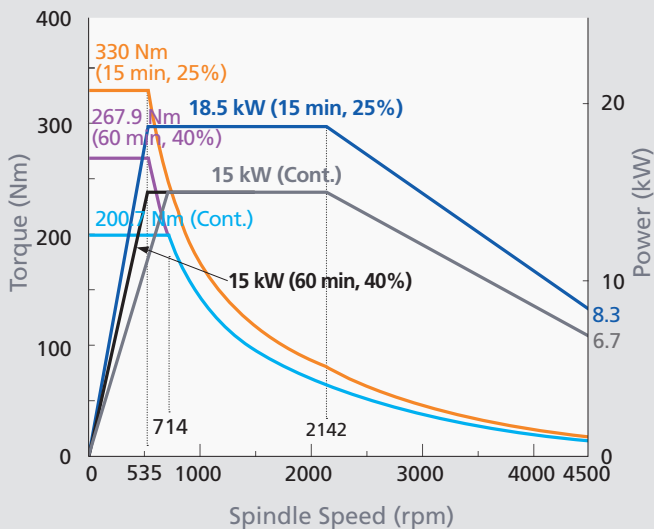

3,500 rpm (Hi-TECH230B)

Max Power : 18.5 kW (25 HP) / Max Torque : 410 Nm

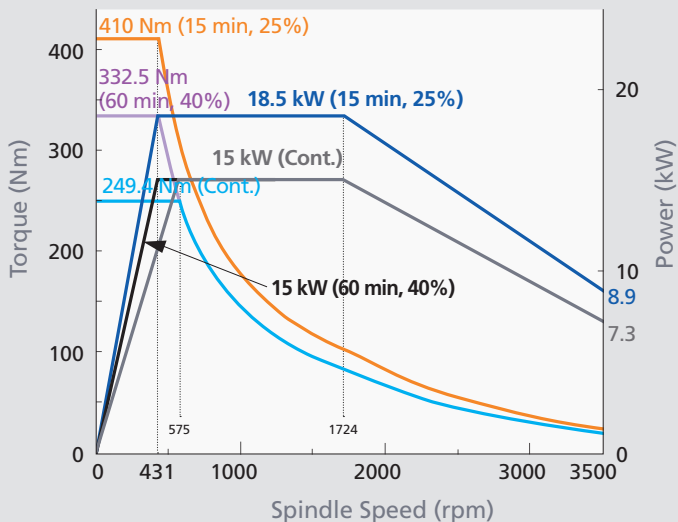

5,000 rpm (Sub Spindle)

Max Power : 7.5kW (10 HP) / Max Torque : 86 Nm

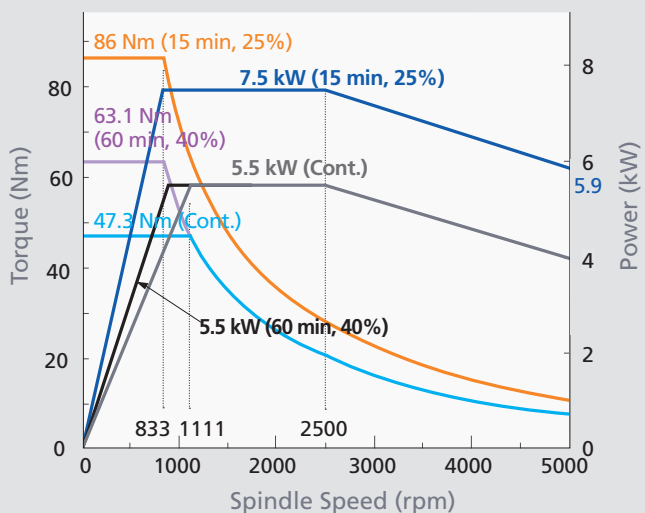

5,000 rpm (Turnmill)



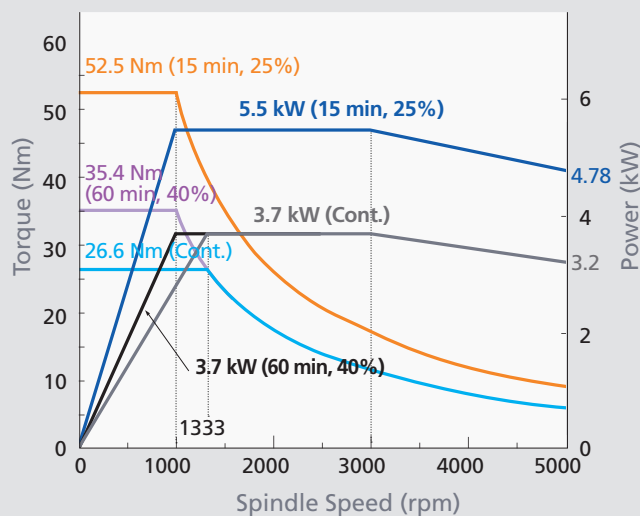







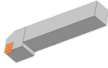

Max Power : 5.5 kW (7.5 HP) / Max Torque : 52.5 Nm

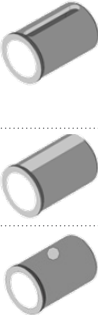

Detailed Information

Tooling Diagram Hi-TECH230 STD

* Unit : ea

Tool	Part name	Q'ty	Shape
 □25 mm (□1 inch)	Block	Hi-TECH 230A, B : 6 Set Hi-TECH 230C : 5 Set	
	Extended O.D Cutting Holder	Hi-TECH 230A, B : 0 Hi-TECH 230C : 1	
	Face Holder	1	
	U-Drill Holder	1	
	I.D Holder	4	
 Ø40 mm (Ø1.5 inch)	Sleeve (Ø12, 1/2")	1	
	Sleeve (Ø16, 5/8")	1	
	Sleeve (Ø20, 3/4")	1	
	Sleeve (Ø25, 1")	1	
	Sleeve (Ø32, 1 1/4")	1	
	Sleeve (Ø32, 1 1/4")	1	
	Socket (MT#1)	1	
	Socket (MT#2)	1	
	Socket (MT#3)	1	
	U-Drill Sleeve (Ø20, 3/4")	OPT	
	U-Drill Sleeve (Ø25, 1")		
	U-Drill Sleeve (Ø32, 1 1/4")		

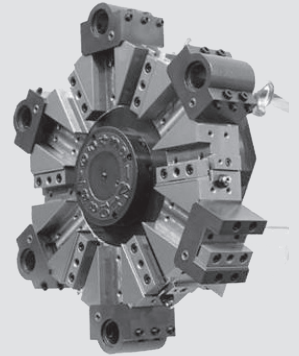

Hi-TECH230 MC

* Unit : ea

Tool	Part name	Q'ty	Shape
 □25 mm (□1 inch)	O.D Cutting Holder	4	
	Face Holder	1	
	Extended O.D Cutting Holder	Hi-TECH 230A, B : 0 Hi-TECH 230C : 1	
 □20 mm (□0.75 inch)	Double O.D Cutting Holder	OPT	
	Double I.D Holder	OPT	
	U-Drill Holder	1	
	I.D Holder	2	
 Ø40 mm (Ø1.5 inch)	Sleeve (Ø12, 1/2")	1	
	Sleeve (Ø16, 5/8")	1	
	Sleeve (Ø20, 3/4")	1	
	Sleeve (Ø25, 1")	1	
	Sleeve (Ø32, 1 1/4")	1	
	Sleeve (Ø32, 1 1/4")	1	
	Socket (MT#1)	1	
	Socket (MT#2)	1	
	Socket (MT#3)	1	
	U-Drill Sleeve (Ø20, 3/4")	OPT	
	U-Drill Sleeve (Ø25, 1")		
	U-Drill Sleeve (Ø32, 1 1/4")		
	ER 32 : Ø3,4,5,6,7,8,9,10,11,12, 13, 14,15, 16, 17, 18, 19, 20 ER 321 : Ø1/8", Ø3/16", Ø1/4", Ø5/16", Ø3/8", Ø7/16", Ø1/2", Ø11/16"	1 Set	
	Cap	12	

[BMT65]

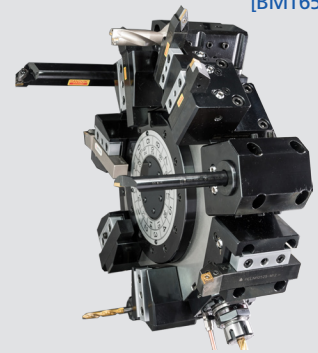

Axial Turnmill Holder (OPT)



Radial Turnmill Holder (OPT)



Turret Interference Diagram

* Unit : mm (inch)

Hi-TECH 230 A/B/C 12 Position STD

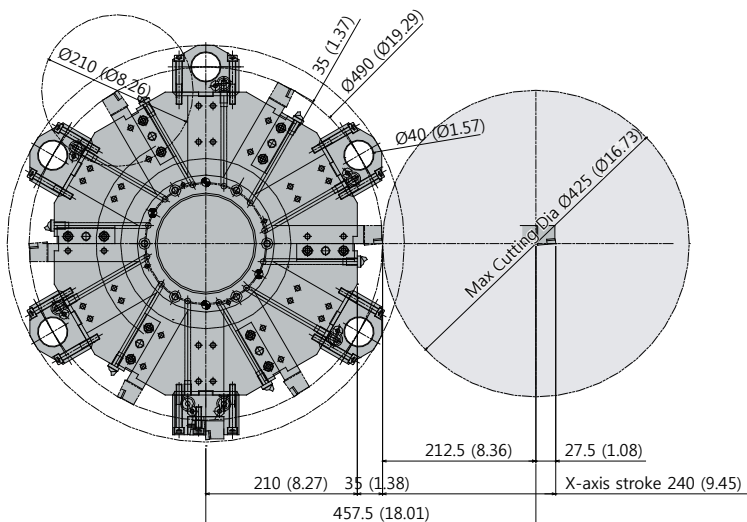

Hi-TECH 230 A/B/C 24 Position MC

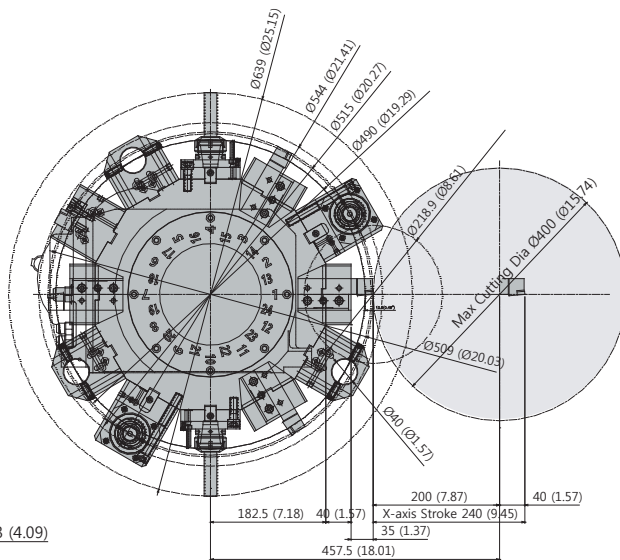

Hi-TECH 230 A/B/C 24 Position Y-axis Moving Range

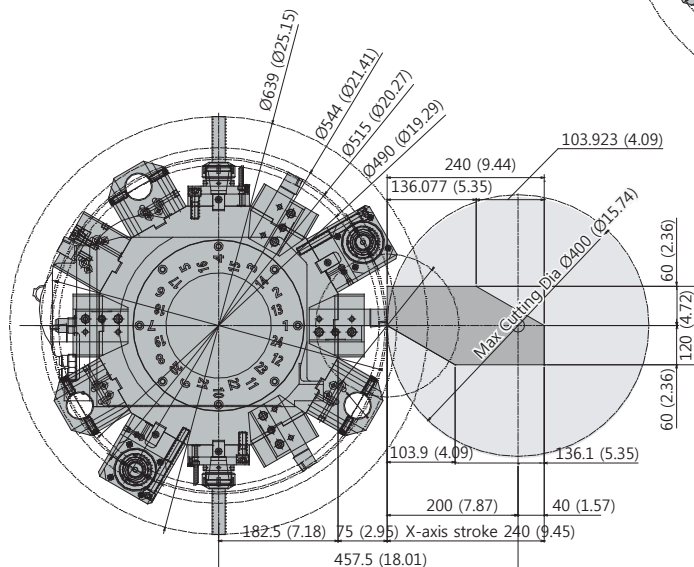

• Detailed Information

Moving Range

Hi-TECH 230A(L) STD O.D & I.D

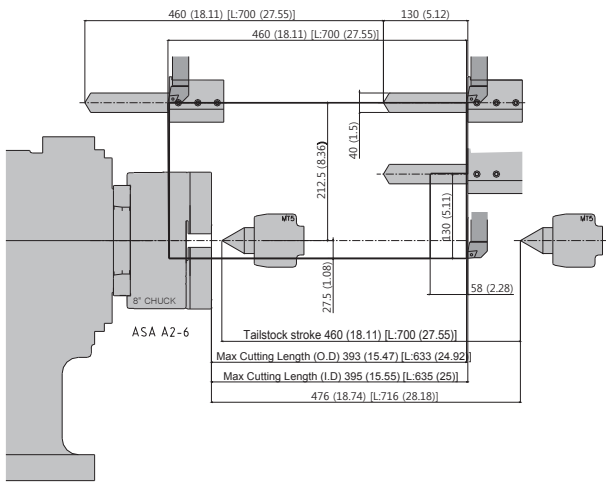

Face Holder

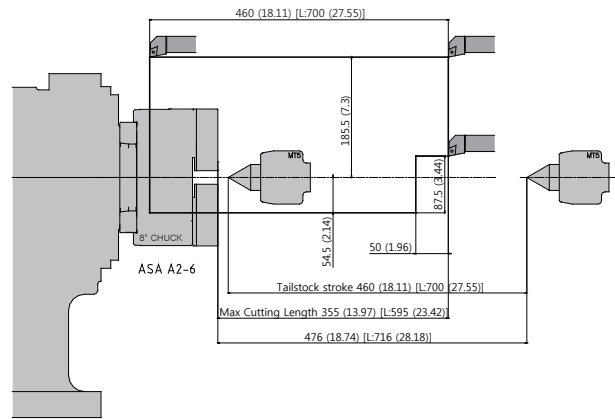

Hi-TECH 230A(L) MC O.D

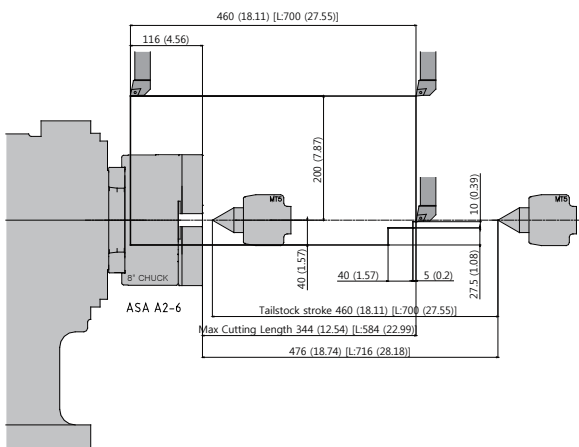

Axial & Radial

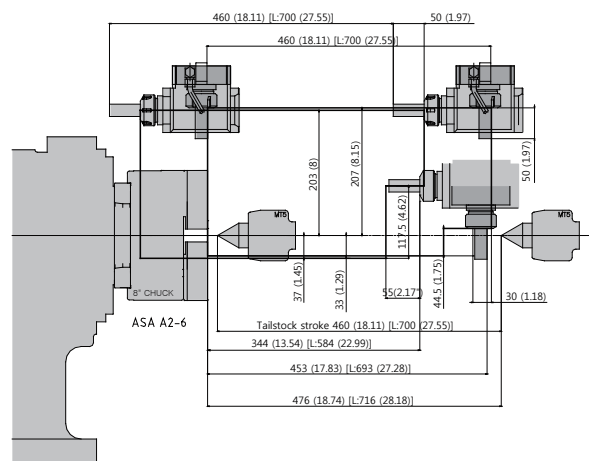

Moving Range

Hi-TECH 230B, C(L) STD O.D & I.D

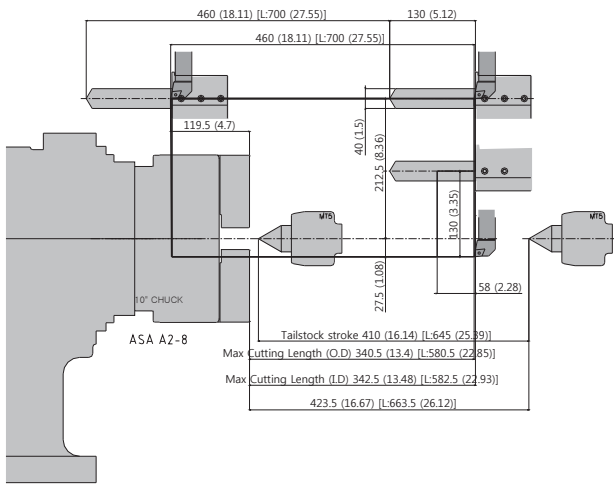

Face Holder

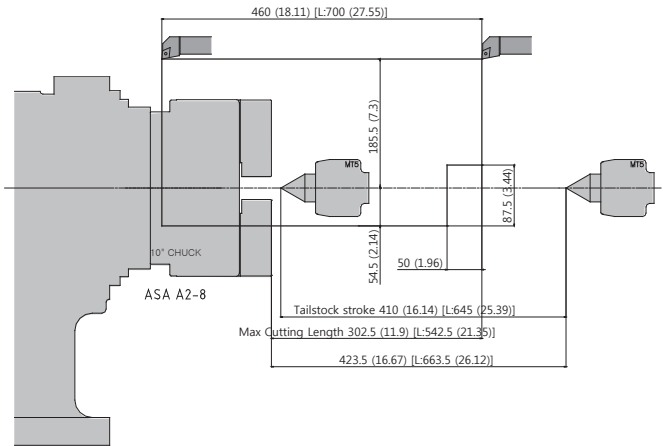

Hi-TECH 230B, C(L) MC O.D

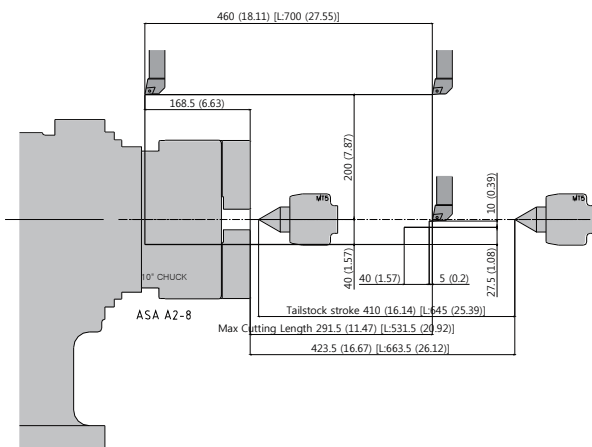

Axial & Radial

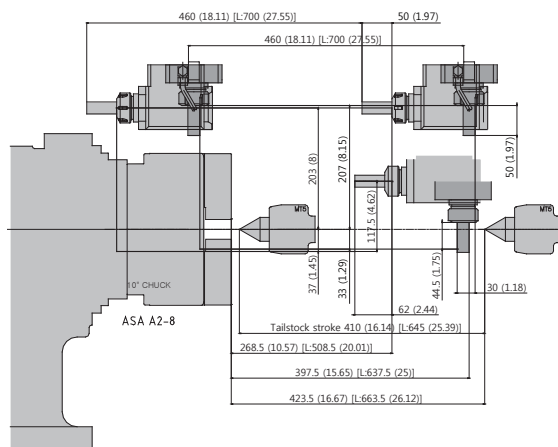

Detailed Information

Product Configuration

Each product can be configured to fit your application.

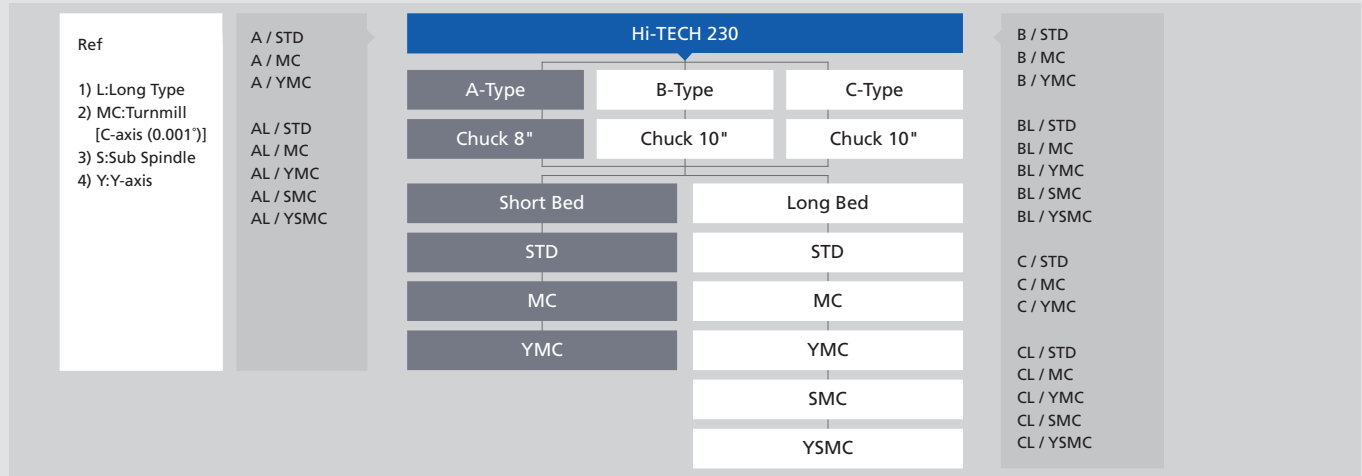

Machine Specifications

Item		Hi-TECH 230A(L) YMC	Hi-TECH 230B(L) YMC	Hi-TECH 230C(L) YMC	Hi-TECH 230AL YSMC	Hi-TECH 230BL YSMC	Hi-TECH 230CL YSMC
Capacity							
Swing over Bed	mm (inch)	Ø750 (Ø29.52)					
Swing over Saddle	mm (inch)	Ø540 (Ø21.25)					
Max Cutting Dia	mm (inch)	Ø425 (Ø16.73) [(Y)MC:Ø400 (Ø15.74)]					
Standard Cutting Dia	mm (inch)	Ø210 (Ø8.26) [(Y)MC:Ø218 (Ø8.58)]					
Max Cutting Length	mm (inch)	393 (15.47) [L:633 (24.92)] [(Y)MC:344 (13.54) [L:584 (22.99)]]	340.5 (13.4) [L:580.5 (22.85)] [(Y)MC:291.5 (11.47) [L:531.5 (20.92)]]	633 (24.92) [(Y)MC:584 (22.99)]	580.5 (22.85) [(Y)MC:531.5 (20.92)]		
Chuck Size	inch	8	10	8 (Sub : 6)	10 (Sub : 6)		
Spindle							
Type of Spindle Nose	ASA	A2-6	A2-8	A2-6 (Sub:A2-5)	A2-8 (Sub:A2-5)		
Max Spindle Speed	rpm	4,500	3,500	4,500 (Sub:5,000)	3,500 (Sub:5,000)		
Through Spindle Hole Dia	mm (inch)	Ø76 (Ø2.99)	Ø91 (Ø3.58)	Ø76 (2.99) [Sub:Ø62 (2.44)]	Ø91 (3.58) [Sub:Ø62 (2.44)]		
Max Bar Size	mm (inch)	Ø65 (Ø2.56)	Ø81 (Ø3.19)	Ø65 (Ø2.56) [Sub:Ø51 (Ø2.01)]	Ø81 (Ø3.19) [Sub:Ø51 (Ø2.01)]		
Spindle Bearing Inner Dia	mm (inch)	Ø110 (Ø4.33)	Ø140 (Ø5.51)	Ø110 (Ø4.33) [Sub:Ø90 (Ø3.54)]	Ø140 (Ø5.51) [Sub:Ø90 (Ø3.54)]		
Spindle Motor	kW (HP)	18.5 / 15 (25 / 20)		22 / 18.5 (30 / 25)	18.5 / 15 (25 / 20) [Sub:7.5 / 5.5 (10 / 7.5)]		22 / 18.5 (30 / 25) [Sub:7.5 / 5.5 (10 / 7.5)]
Turret							
Number of Tool Stations	ea	STD:12, MC/SMC/YMC/YSMC: 12 (24 Positions Index)					
Tool Size	mm (inch)	O.D:□25 (□1), I.D:Ø40 (Ø1.57)					
Turret Indexing Time	sec/step	0.344					
Axes							
Rapid Speed (X / Z / Y / B)	m/min (ipm)	30 / 30 / 10 / - (1,181 / 1,181 / 393.7 / -)			30 / 30 / 10 / 24 (1,181 / 1,181 / 393.7 / 944)		
Max Stroke (X / Z / Y / B)	mm (inch)	240 / 460 (L:700) / 120 / - [9.45 / 18.11 (L:27.56) / 4.72 / -]			240 / 700 / 120 / 700 [9.45 / 27.56 / 4.72 / 27.56]		240 / 700 / 120 / 647.5 [9.45 / 27.56 / 4.72 / 25.49]
Feed Motor (X / Z / Y / B)	kW (HP)	3.0 / 3.0 / 3.0 / - (4 / 4 / 4 / -)		4.0 / 4.0 / 4.0 / - (5.4 / 5.4 / 5.4 / -)	3.0 / 3.0 / 3.0 / 1.6 (4 / 4 / 4 / 2.2)		4.0 / 4.0 / 4.0 / 1.6 (5.4 / 5.4 / 5.4 / 2.2)
Tailstock							
Max Stroke	mm (inch)	460 (18.11) [L:700 (27.56)]	410 (16.14) [L:645 (25.39)]			-	
Cylinder Diameter	mm (inch)	Ø50 (Ø1.97)					
Center Taper	MT	# 5					
Turnmill							
Spindle Motor	kW (HP)	5.5 / 3.7 (7.5 / 5)					
Max Spindle Speed	rpm	5,000					
Max Drill/Tap Size	mm (inch)	Ø20 (Ø0.79) / M16					
Min. Index Angle	deg	0.001 (Sub:0.001)					
Tank							
Lubrication	ℓ (gal)	12 (3.17)					
Hydraulic	ℓ (gal)	11 (2.9)					
Coolant	ℓ (gal)	160 (42.27)			175 (46.23)		
Power Sources							
Electrical Power Supply	kVA	STD / MC / YMC:40, SMC / YSMC:45					
Dimension							
Height	mm (inch)	1,800 (Y:2,104) [70.86 (Y:82.83)]					
Floor Space (LxW)	mm (inch)	2,873 (L:3,133) x 1,849.5 (Y:1,924.5) [113.11 (L:123.35) x 72.81 (Y:75.76)]			3,133 x 1,849.5 (Y:1,924.5) [123.35 x 72.81 (Y:75.76)]		
Weight	kg; (lb)	STD:4,050 (8,929) [L:4,350 (9,590)] / MC:4,200 (9,259) [L:4,500 (9,920)] YMC:4,400 (9,700) [L:4,700 (10,361)] / YSMC:4,650 (10,251) [L:4,950 (10,912)]					
NC Controller		Fanuc 0i-TF					

NC Specifications [Fanuc 0i-TF]

※ — : Not available S : Standard O : Option

Item	Specification	STD	MC	SMC	YMC	YSMC
Controlled Axis						
Controlled Axis (Cs Axis)	2 - Axes	2-Axes	3-Axes	5-Axes	4-Axes	6-Axes
Simultaneously Controlled Axes	2 - Axes	2-Axes	3-Axes	4-Axes	4-Axes	4-Axes
Least Input Increment	0.001 mm, 0.001 deg, 0.0001 inch	S	S	S	S	S
Least Input Increment 1 / 10	0.0001 mm, 0.0001 deg, 0.00001 inch	O	O	O	O	O
Inch / Metric Conversion	G20, G21	S	S	S	S	S
Store Stroke Check 1		S	S	S	S	S
Store Stroke Check 2, 3		S	S	S	S	S
Chamfering on / off		S	S	S	S	S
Backlash Compensation		S	S	S	S	S
Operation						
Automatic & MDI Operation		S	S	S	S	S
Program Number Search		S	S	S	S	S
Sequence Number Search		S	S	S	S	S
Dry Run, Single Block		S	S	S	S	S
Manual Handle Feed	1Unit	S	S	S	S	S
Manual Handle Feed Rate	x1, x10, x100	S	S	S	S	S
Interpolation Function						
Positioning	G00	S	S	S	S	S
Linear Interpolation	G01	S	S	S	S	S
Circular Interpolation	G02,G03	S	S	S	S	S
Dwell (Per Seconds)	G04	S	S	S	S	S
Polar Coordinate Interpolation	G12.1 / G13.1	-	S	S	S	S
Cylindrical Interpolation	G7.1	-	S	S	S	S
Threading	G32	S	S	S	S	S
Multiple Threading		S	S	S	S	S
Continuous Threading		S	S	S	S	S
Threading Retract		S	S	S	S	S
Variable Lead Threading	G34	S	S	S	S	S
Ref Position Return 1st	G28	S	S	S	S	S
Ref Position Return Check	G27	S	S	S	S	S
2 / 3 / 4th Ref Position Return	G30	S	S	S	S	S
Feed Function						
Rapid Traverse Override	F0, F25, F50, F100	S	S	S	S	S
Feed Per Minute (mm/min)	G98	S	S	S	S	S
Feed Per Revolution (mm/rev)	G99	S	S	S	S	S
Rapid Traverse Bell-shaped Acceleration / Deceleration		S	S	S	S	S
Feedrate Override	0 ~ 150%	S	S	S	S	S
Jog Feed Override	0 ~ 1,260 mm/min	S	S	S	S	S
Program Input						
Tape Code	EIA / ISO	S	S	S	S	S
Optional Block Skip	9 ea	S	S	S	S	S
Program Number	O4 - Digits	S	S	S	S	S
Sequence Number	N8 - Digits	S	S	S	S	S
Decimal Point Programming		S	S	S	S	S
Coordinate System Setting	G50	S	S	S	S	S
Coordinate System Shift		S	S	S	S	S
Workpiece Coordinate System (G54 ~ G59)		S	S	S	S	S
Workpiece Coordinate System Preset (G92.1)		S	S	S	S	S
Direct Drawing Dimension Programming		S	S	S	S	S

Item	Specification	STD	MC	SMC	YMC	YSMC
Program Input						
G Code System	A	S	S	S	S	S
Programmable Data Input	G10	S	S	S	S	S
Sub Program Call	10 folds nested	S	S	S	S	S
Custom Macro B		S	S	S	S	S
Addition of Custom Macro -common Variables	#100 ~ #199, #500 ~ #999	S	S	S	S	S
Canned Cycles		S	S	S	S	S
Multiple Repetitive Cycle		S	S	S	S	S
Multiple Repetitive Cycle II		S	S	S	S	S
Canned Cycles for Drilling		S	S	S	S	S
Manual Guide i		S	S	S	S	S
Spindle Speed Function						
Constant Surface Speed Control	G96 / G97	S	S	S	S	S
Spindle Override	50 ~ 120%	S	S	S	S	S
Spindle Orientation		S	S	S	S	S
Rigid Tapping		S	S	S	S	S
Spindle Synchronous Control		-	-	S	-	S
Tool Function / Compensation						
Tool Function	T4-digits	S	S	S	S	S
Tool Offset Pairs	128 pairs	S	S	S	S	S
Tool Nose Radius Compensation		S	S	S	S	S
Tool Geometry / Wear Compensation		S	S	S	S	S
Tool Life Management		O	O	O	O	O
Automatic Tool Offset		O	O	O	O	O
Direct Input Tool Offset Value Measured B	Tool presetter option is required	O	O	O	O	O
Editing Operation						
Part Program Storage Length	1,280 m (512 kB)	S	S	S	S	S
Number of Register Able Programs	400 ea	S	S	S	S	S
Background Editing		S	S	S	S	S
Extended Part Program Editing		S	S	S	S	S
Play Back		S	S	S	S	S
Operation / Display						
Clock Function		S	S	S	S	S
Self-diagnosis Function		S	S	S	S	S
Alarm History Display		S	S	S	S	S
Help Function		S	S	S	S	S
Run Hour and Parts Count Display		S	S	S	S	S
Graphic Function		S	S	S	S	S
Dynamic Graphic Display		O	O	O	O	O
Multi-language Display	Korean, English, German, French, Italian, Chinese, Spanish, Portuguese, Polish, Hungarian, Swedish, Russian	S	S	S	S	S
Data Input / Output						
Reader / Puncher Interface Ch1	RS232C	S	S	S	S	S
Reader / Puncher Interface Ch2	RS232C	S	S	S	S	S
Ethernet Interface		S	S	S	S	S
Memory Card Interface		S	S	S	S	S
USB Card Interface		S	S	S	S	S
Others						
Display Unit	10.4" Color LCD	S	S	S	S	S

Hwacheon Global Network

 Hwacheon Headquarters  Hwacheon Europe  Hwacheon Asia  Hwacheon America



HWACHEON

Please call us for product inquiries.

www.hwacheon.com

The product design and specifications may change without prior notice.
Read the operation manual carefully and thoroughly before operating the product,
and always follow the safety instructions and warnings labels attached on the surfaces of the machines.

HEAD OFFICE

HWACHEON MACHINE TOOL CO., LTD.

123-17, HANAMSANDAN 4BEON-RO, GWANGSAN-GU, GWANGJU, KOREA
TEL: +82-62-951-5111 FAX: +82-62-951-0086

SEOUL OFFICE

46, BANGBAE-RO, SEOCHO-GU, SEOUL, KOREA
TEL: +82-2-523-7766 FAX: +82-2-523-2867

USA

HWACHEON MACHINERY AMERICA, INC.

555 BOND STREET, LINCOLNSHIRE, ILLINOIS, 60069, USA
TEL: +1-847-573-0100 FAX: +1-847-573-9900

SINGAPORE

HWACHEON ASIA PACIFIC PTE. LTD.

21 BUKIT BATOK CRESCENT, #08-79 WCEGA TOWER, SINGAPORE 658065
TEL: +65-6515-4357 FAX: +65-6515-4358

GERMANY

HWACHEON MACHINERY EUROPE GMBH

JOSEF-BAUMANN STR. 25, 44805, BOCHUM, GERMANY
TEL: +49-234-912-816-0 FAX: +49-234-912-816-60