

**FREJOTH**

# HYDRAULIC CRANKSHAFT GRINDER 油壓式曲柄軸研磨床

MODELS: 1600, 2100, 2500, 3000

TYPE: H-HYDRAULIC TABLE TRAVERSE  
E-ELECTRIC TABLE TRAVERSE

### FEATURES:

- 1 Quick setting-up throwheads permits the work easy for operation.
- 2 Hydraulic wheelhead control with quick approach and return.
- 3 Hydraulic control of indexing pins for the locking of face plate.
- 4 Electric rapid traverse for table.
- 5 Air bearing provides convient means of moving the work head and tailstock.
- 6 Heavy bed provides a rigid base to carry all units and possesses great stiffness, and Sufficient slideway length to support the table in all position.

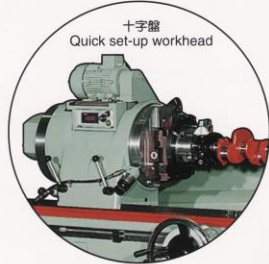

### 機器特性:

- 1 特殊十字盤結構，操作簡便。
- 2 砂輪座油壓快速進退刀裝置，提高工作效率。
- 3 面盤分度定鎖插銷油壓控制動作確實。
- 4 工作台左右快速自動移位。
- 5 工作頭及尾座特殊空氣軸承設計、移位輕便省力。
- 6 床台基座，穩固剛性特佳。

### STANDARD EQUIPMENT:

- 1 Three-jaws chucks with plates
- 2 Centers
- 3 Wheel dresser
- 4 Set-up indicator
- 5 Balancing mandrel
- 6 Standard wheel
- 7 Splash guard
- 8 Diamond dressing tool
- 9 Wheel hub
- 10 Wheel extractor
- 11 Tools and tool box
- 12 Counterweights.

### 標準附件:

- 1 三爪夾頭
- 2 頂針
- 3 砂輪修整座
- 4 中心校正儀
- 5 平衡蕊軸
- 6 標準砂輪
- 7 防水板
- 8 鑽石刀
- 9 砂輪法蘭
- 10 砂輪拆卸器
- 11 工具及工具箱
- 12 配重

### EXTRA EQUIPMENT:

- Wheel balancing unit
- Magnetic coolant filter
- Radius wheel dresser
- 2-point steady rest
- Extra wheel
- Extra wheel hub

### 特殊附件:

- 砂輪平衡儀
- 磁性冷卻除屑機
- 圓弧砂輪修整儀
- 兩點式中心架
- 額外砂輪
- 額外砂輪法蘭

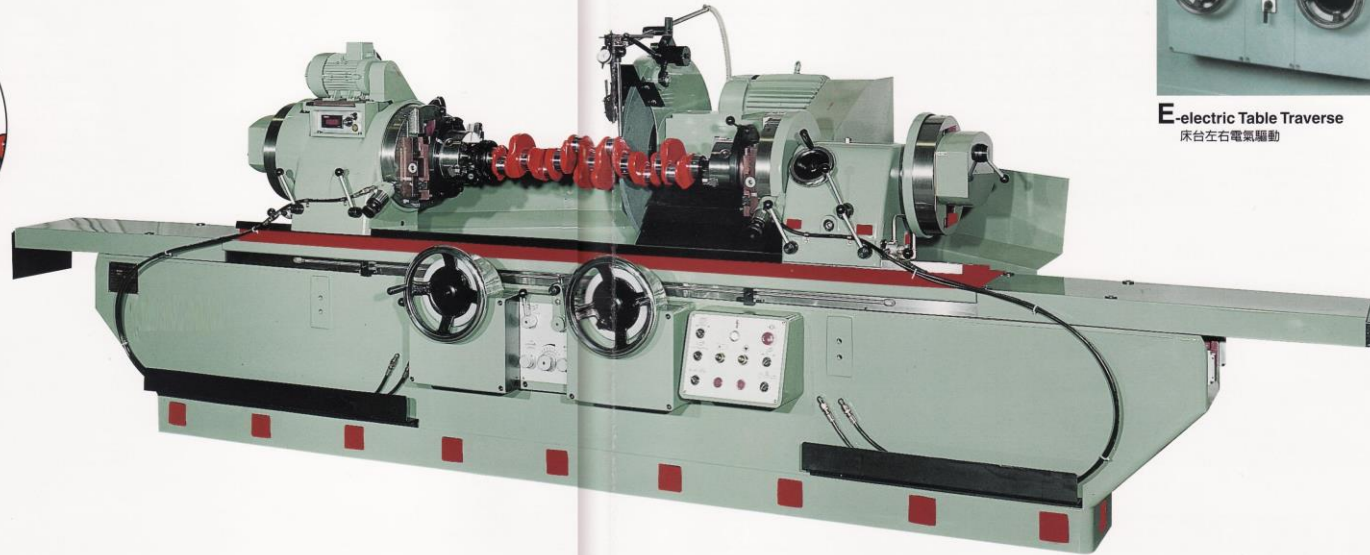

**H-hydraulic Table Traverse**  
床台左右油壓驅動



**E-electric Table Traverse**  
床台左右電氣驅動

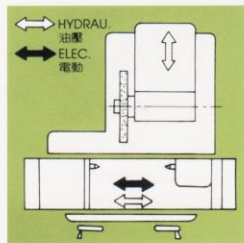

### OPTIONAL ACCESSORIES 選擇性配件



Extra wheel hub  
額外砂輪法蘭



Wheel balancing unit  
砂輪平衡儀



Magnetic coolant filter  
磁性冷卻除屑機



Radius wheel dresser  
圓弧砂輪修整儀

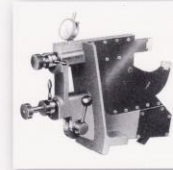

2-point steady rest  
兩點式中心架



Extra wheel  
額外砂輪

**SPECIFICATION 規格**

ITEMS		MODEL	1600	2100	2500	3000
Capacity 能量	Max. distance between centers 頂心間距離	MM(IN.)	1650(65)	2170(85 <sup>1</sup> / <sub>2</sub> )	2570(101 <sup>1</sup> / <sub>8</sub> )	3070(120 <sup>7</sup> / <sub>8</sub> )
	Max. distance between chucks 夾頭間距離	MM(IN.)	1600(63)	2100(82 <sup>5</sup> / <sub>8</sub> )	2500(98 <sup>1</sup> / <sub>2</sub> )	3000(118 <sup>1</sup> / <sub>8</sub> )
	Center height 中心高度	MM(IN.)	275(10 <sup>13</sup> / <sub>16</sub> )	350(13 <sup>13</sup> / <sub>16</sub> )		
	Swing over table(φ)旋徑	MM(IN.)	550(21)	700(27 <sup>1</sup> / <sub>2</sub> )		800(31 <sup>1</sup> / <sub>4</sub> )
	Stroke 衝程	MM(IN.)	200(7 <sup>7</sup> / <sub>8</sub> )	280(11")	340(13 <sup>1</sup> / <sub>32</sub> )	
	Wheelhead quick approach distance 砂輪頭快送距離	MM(IN.)	150(5 <sup>7</sup> / <sub>8</sub> )	165(6 <sup>1</sup> / <sub>2</sub> )	180(7 <sup>15</sup> / <sub>16</sub> )	
	Max. weight of crankshaft 最大工具重量	KG	350	500	800	1000
Operation Speeds 操作速率	Workhead spindle speeds 主軸蕊軸速度	RPM	20-100	10-100	10-100	
	Table traverse manual 床台左右手動	MM	4.5/Turn			
	Table traverse electric 床台左右電動	MM/MIN.	2800			
	Table traverse hydraulic 床台左右油壓	MM/MIN.	60-3000			
	Wheelhead feed per graduation 砂輪頭每格進刀量	MM(IN.)	0.0025(0.0001)			
Grinding Wheel 砂輪尺寸	Diameter 直徑	MM(IN.)	710(28)	812(32)		915(36)
	Width (MIN.~MAX.) 寬度 (最少~最大)	MM(IN.)	19-38(3/4-1 <sup>1</sup> / <sub>2</sub> )	22-38(7/8-1 <sup>1</sup> / <sub>2</sub> )		
	Bore 孔徑	MM(IN.)	203(8)			305(12)
Motors 馬達	Wheelhead 砂輪頭	HP	10	15		15
	Workhead 主軸頭	HP	2	3		5
	Table traverse electric 床台左右電動	HP	1	E-electric Table Traverse 床台左右電氣驅動設計		
	Hydraulic system 油壓系統	HP	2			3
	Lubrication system 潤滑系統	HP	1/4			
	Coolant system 冷卻水系統	HP	1/8			1/4
Shipping Dimension 裝箱尺寸	Machine weight(Net) 機器淨重	KG	5200	7000	9500	11000
	Machine weight(Export) 機器總重	KG	6500	8100	10500	13500
	Box size 外箱尺寸	MM	4600x1950x2000	6000x2160x2200	7000x2200x2250	8000x2250x2250

**MACHINE DIMENSION 機器外型尺寸圖**

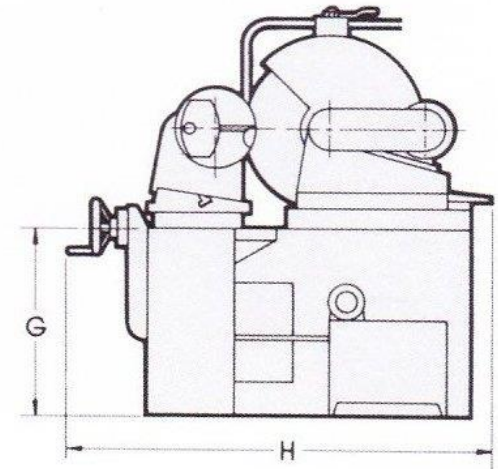
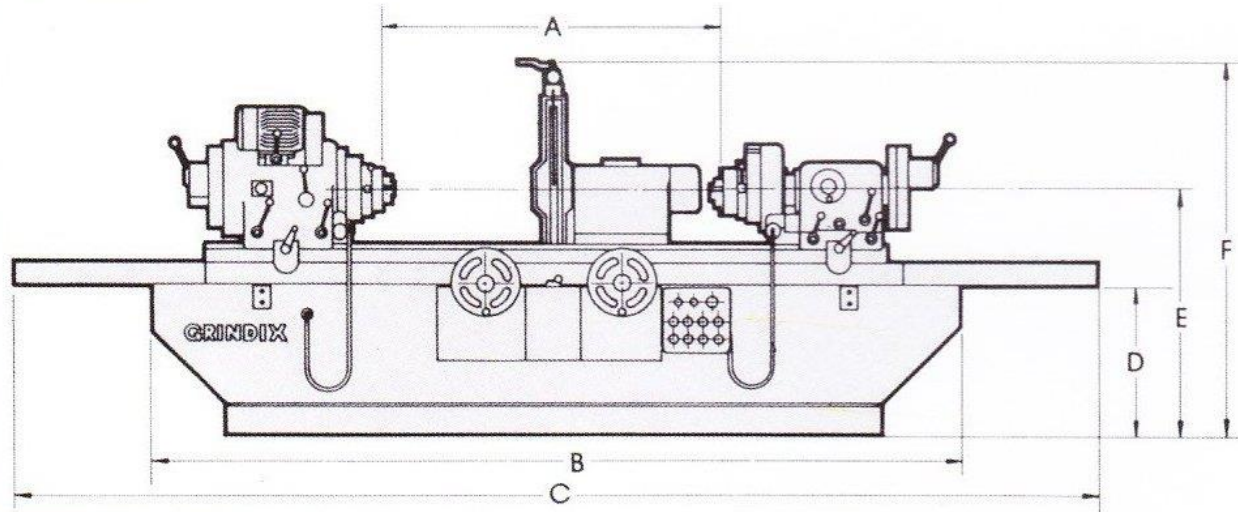

MODEL	A	B	C	D	E	F	G	H
<b>1600</b>	1600 (63)	4200 (165)	5100 (200.39)	650 (25 <sup>5</sup> / <sub>8</sub> )	1060 (41 <sup>3</sup> / <sub>4</sub> )	1600 (63)	650 (25 <sup>1</sup> / <sub>2</sub> )	1860 (73 <sup>1</sup> / <sub>4</sub> )
<b>2100</b>	2100 (82 <sup>2</sup> / <sub>3</sub> )	5500 (216.54)	6300 (248 <sup>0.3</sup> )	650 (25 <sup>5</sup> / <sub>8</sub> )	2100 (45 <sup>11</sup> / <sub>64</sub> )	1850 (72 <sup>7</sup> / <sub>8</sub> )	650 (25 <sup>1</sup> / <sub>2</sub> )	1900 (74.8)

MODEL	A	B	C	D	E	F	G	H
<b>2500</b>	2500 (98 <sup>1</sup> / <sub>2</sub> )	6300 (248.03)	7100 (279.53)	650 (25 <sup>7</sup> / <sub>8</sub> )	1160 (45 <sup>11</sup> / <sub>64</sub> )	2000 (78 <sup>3</sup> / <sub>4</sub> )	650 (25 <sup>1</sup> / <sub>2</sub> )	1900 (74.8)
<b>3000</b>	3000 (118 <sup>1</sup> / <sub>10</sub> )	7500 (295.28)	8400 (330.71)	650 (23 <sup>1</sup> / <sub>2</sub> )	1310 (51 <sup>1</sup> / <sub>2</sub> )	2230 (87 <sup>4</sup> / <sub>5</sub> )	530 (20 <sup>7</sup> / <sub>8</sub> )	2000 (78.74)