



CNC HORIZONTAL BORING
& MILLING MACHINE



Conventional Horizontal Boring & Milling Machine UBM series

CNC Horizontal Boring & Milling Machining (FIXED COLUMN) UBM-RS series

CNC Double Column Machining Center UDM series

CNC Horizontal Machining Center UHM series

CNC Horizontal Boring & Milling Machining (MOVABLE COLUMN) UBM-R series

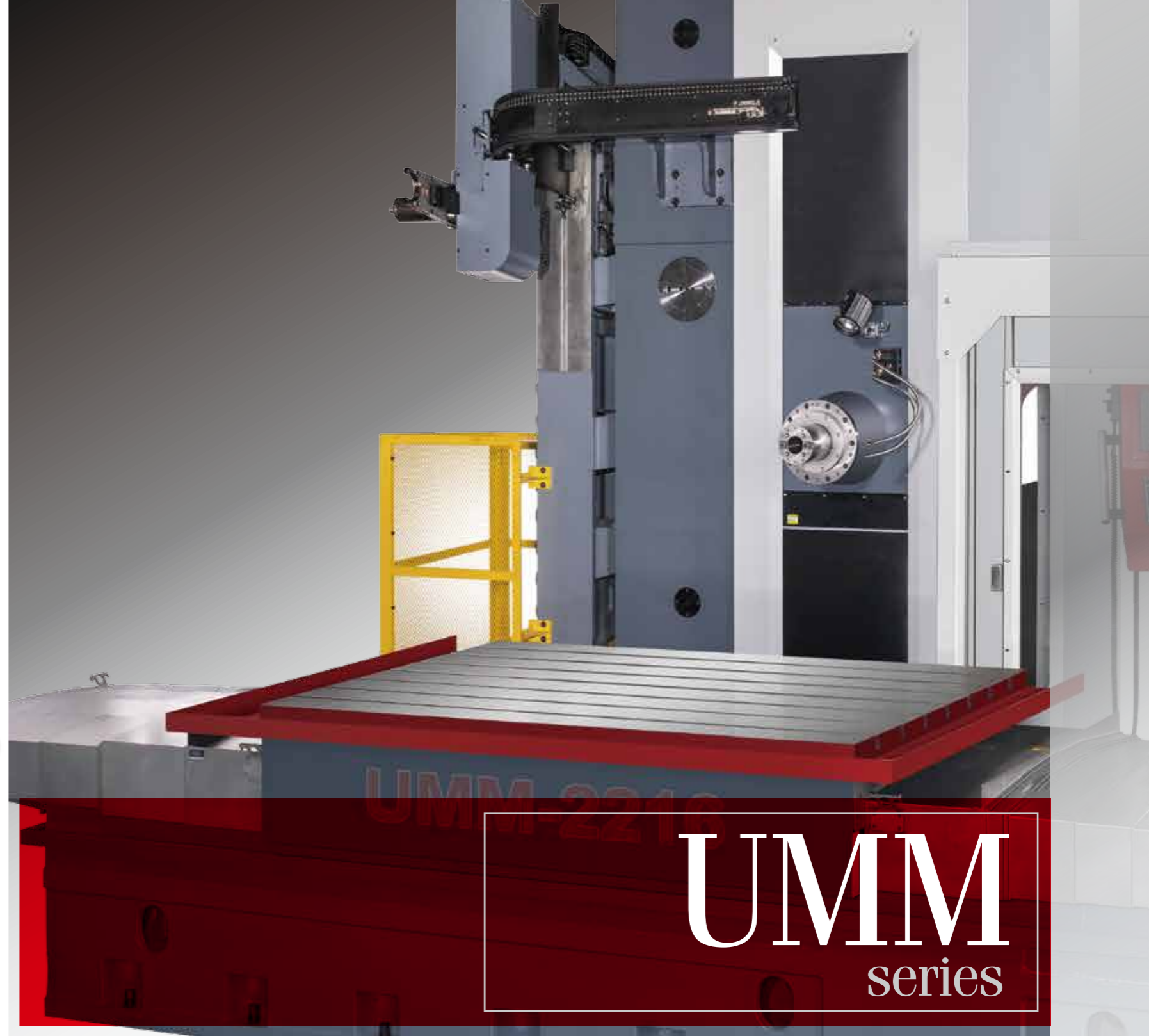

UMM
series

CNC Horizontal Heavy Duty Milling Machine

UMM / UMM-R SERIES

CNC HORIZONTAL HEAVY DUTY MILLING MACHINE

- 3500rpm standard spindle with 130mm diameter produces torque output up to 1323.2Nm, making the machine ideal for heavy cutting.
- Movable column construction allows the table (X-axis) to support extra heavy load.
- All slideways are supported by the main walls of the machine base for increased rigidity.
- To meet the requirement for 3D high speed machining for molds and dies, 4000rpm belt type spindle (Max. torque 992.4Nm) and 6000rpm belt type spindle (Max. torque 661.6Nm) are available upon request.

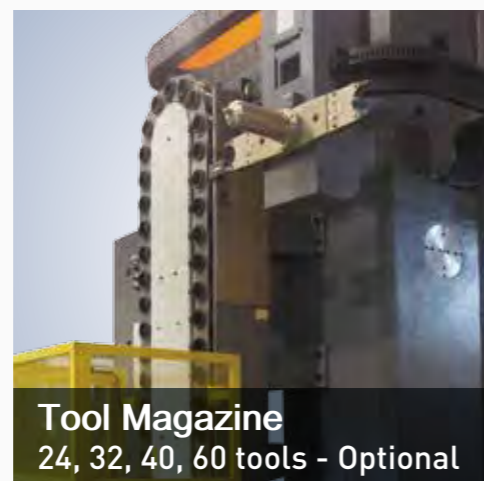
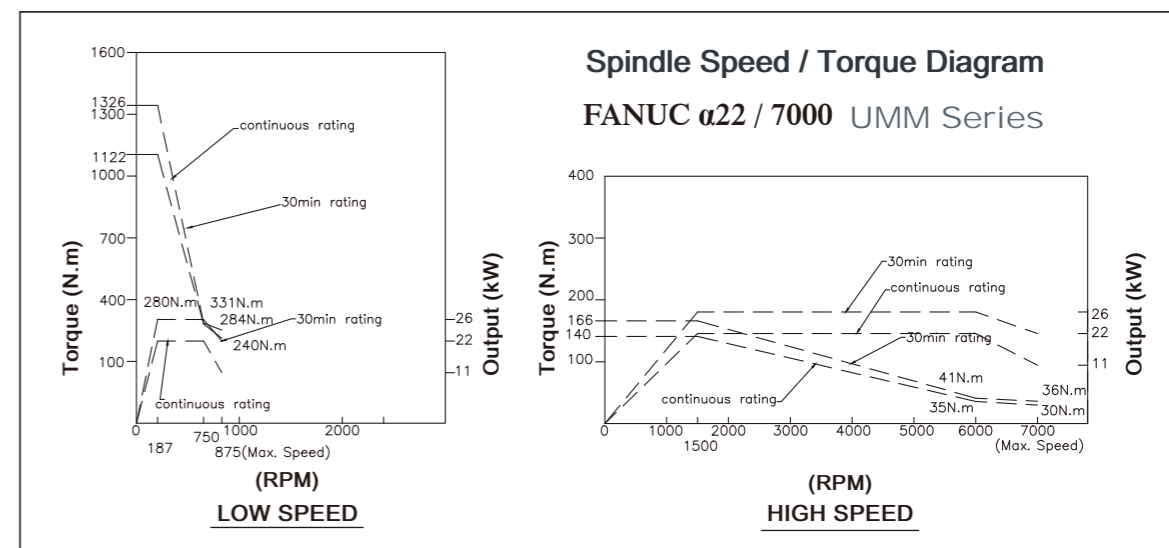
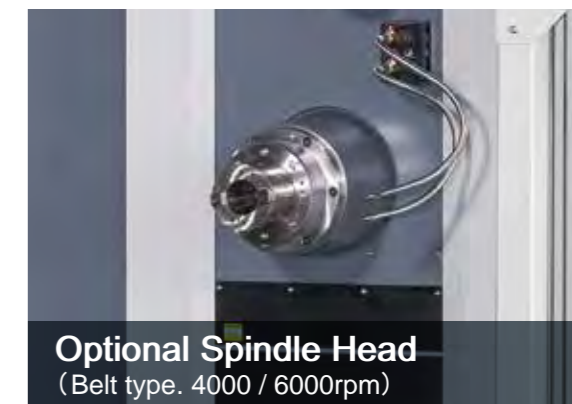
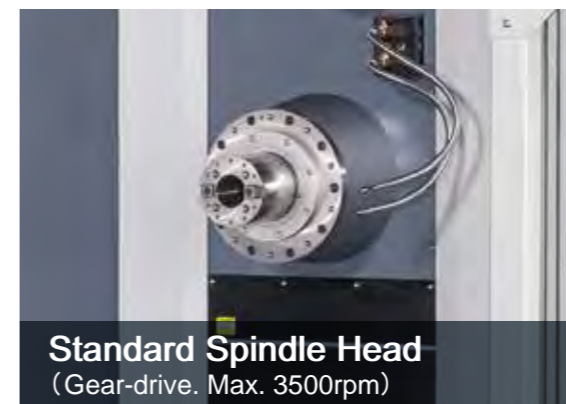

UMM / UMM-R SERIES

CNC HORIZONTAL HEAVY DUTY MILLING MACHINE

- UMM-2216 equipped with optional ATC and automatic vertical & horizontal head. (3500rpm)



- UMM-2516R

STANDARD ACCESSORY:
Standard splash guard

UMM / UMM-R MACHINE SPECIFICATIONS

(): As Optional

MODLE		UNIT	UMM-2216	UMM-2616	UMM-3216	UMM-4216	UMM-2016R	UMM-2516R	UMM-3216R	UMM-4216R	
TABLE	Table Size	mm	2000x1400	2400x1400	3000x1400	4000x1400	1600 x 1400 x 0.001°				
	T-slots Size	mm	22				24				
	Maximum Load	kg	15000	18000	20000	25000	8000				
TRAVEL	X-Axis	mm	2200	2600	3200	4200	2000	2500	3200	4200	
	Y-Axis	mm	1600								
	Z-Axis	mm	1200 (1700)								
SPINDLE	Speed	rpm	3500 (4000, 6000 Belt drive)								
	Taper		7/24 Taper ISO.50, BT-50								
DISTANCES	Spindle Center to Table Surface	mm	0~1600								
	Spindle Nose to Table Center	mm	350~1550 (2050)				360~1560 (2060)				
	Height From Ground to Table Surface	mm	1180				1250				
FEED RATE	Rapid Feed Rate X/Y/Z/W	m/min	10								
	Minimum Setting	mm	0.001								
	Cutting Feed Rate	mm/min	1~5000								
MOTOR	Spindle Servo Motor-cont. / 30min	kW	22 / 26								
	Axis X/Y/Z/B	kW	7 / 4 / 4				7 / 4 / 4 / 7				
	Lubricator Motor	kW	0.15								
	Hydraulic Pump	kW	2.25								
	Coolant Pump	kW	1.62								
	Chip Conveyor	kW	0.25								
	Oil Cooler Pump	kW	3.6								
ATC	No. of Tools	pieces	(24, 32, 40, 60)								
	Tool Selection		Absolute								
	Tool Change Time (approx.) [T to T]	Sec.	15								
COOLANT & LUBRICATION	Max. Tool-Diameter / Length	mm	Ø125/Ø250 (Without Adjacent Tool) / Length 400								
	Max. Tool Weight	kg	25								
	Coolant Tank Volume	L	400								
MISCELLANEOUS	Hydraulic Tank Volume	L	80								
	Lubrication Tank Volume	L	8								
	Power Required	kVA	55								
MISCELLANEOUS	Pressurized Air	kg/cm ²	6								
	Machine Weight	ton	26	29	31	36.5	27	28	29.5	31	

■ Specifications are subject to change without prior notice.

STANDARD ACCESSORIES :

1. Spindle oil cooler
2. Automatic power off
3. Hydraulic system
4. Coolant system
5. Lubricator system
6. Alarm lamp
7. Work lamp
8. M.P.G.
9. RS-232 interface
10. Heat exchanger
11. Chip conveyor and cart
12. Leveling bolts & pads
13. Controller manuals and circuit diagram
14. Operation manuals
15. Machine inspection lists
16. Toolbox with spanners & wrenches
17. FANUC OiMF
18. Splash guards
(around the operator and work table)

OPTIONAL ACCESSORIES :

1. Y-axis travel: 2000 mm
2. Z-axis travel: 1700 mm
3. Linear scale on X, Y, Z axes
4. ATC: 24, 32, 40, 60 Tools
5. Spindle speed 4,000rpm or 6,000rpm
6. Air conditioner at the electrical cabinet
7. Coolant through spindle
8. Large splash guards
9. Rotary table: 1800x1600x0.001°, loading 15 tons
(for UMM-XXXXR series)
10. Simultaneously controlled rotary table

UMM-RW SERIES

CNC HORIZONTAL HEAVY DUTY MILLING MACHINE

- W-axis is a square ram structure. Extension is 600mm (800mm optional)
- Box ways on X-axis. Linear guide ways are optional.
- Y-axis is supported by 4 linear guide ways. The front two are 55mm roller type linear guide ways with 3 blocks on each way. The back two are 35mm roller type linear guide ways with 2 blocks on each way. This design provides effective suppression for spindle deflection.
- The spindle is center-mounted for superb rigidity.
- Z-axis is fitted with 4 sets of 55mm roller type linear guide ways, featuring maximum rigidity and stability.



- The column is designed with a double-wall cage shaped structure, which not only exhibits ultra high rigidity but also provides outstanding accuracy.
- Y-axis is transmitted by a $\text{Ø}63\text{mm}$, class C3 precision ball screw and supported by 4 linear guide ways to achieve maximum feed stability and rigidity.
- The counter-balance weights are equipped at both sides of the column, allowing for even distribution of weight. This combined with the use of linear guide ways makes spindle head movement smoother.

UMM-W / UMM-RW

[]: As Optional

- Two linear ways are equipped at the back side to keep the spindle head well-balanced. When the W-axis extends, it may effectively suppress the spindle deflection.



MODLE		UNIT	UMM-2216W	UMM-2616W	UMM-3216W	UMM-4216W	UMM-2016RW	UMM-2016RWA	UMM-2516RW	UMM-3216RW	UMM-4216RW		
TABLE	Table Size	mm	2000x1400	2400x1400	3000x1400	4000x1400	1250x1250x1°(1400x1600)	1250x1250x1°(twin station)	1400x1600x0.001°				
	T-slots Size	mm	22						22 (24)		24		
	Maximum Load	kg	15000	18000	20000	25000	5000		8000				
TRAVEL	X-Axis	mm	2200	2600	3200	4200	2000		2500	3200	4200		
	Y-Axis	mm	1600 (2000)						1600 (2000)				
	Z-Axis	mm	1200 (1700)						1200 (1600)		1200 (1700)		
	W-Axis (Ram type)	mm	600 (800)						600 (800)				
SPINDLE	Speed	rpm	6000 (4000)						6000 (4000)				
	Taper		7/24 Taper ISO.50, BT-50						7/24 Taper ISO.50, BT-50				
DISTANCES	Spindle Center to Table Surface	mm	250~1850 (2250)						250~1850 (2250)				
	Spindle Nose to Table Center	mm	200~2000 (2500) [0~2000 (2500)]						200~2000 (2400) [0~2000 (2400)]		200~2000 [0~2000 (2500)]		
	Height From Ground to Table Surface	mm	1250						1250				
FEED RATE	Rapid Feed Rate X/Y/Z/W	m/min	10						10				
	Minimum Setting	mm/min	0.001						0.001				
	Cutting Feed Rate	mm/min	1~5000						1~5000				
MOTOR	Spindle Servo Motor-cont. / 30min	kW	22 / 26						22 / 26				
	Axis X/Y/Z/W/B	kW	7 / 4 / 4 / 4 / 4						4 (7) / 4 / 4 / 4 / 4 (7)		7 / 4 / 4 / 4 / 7		
	Lubricator Motor	kW	0.15						0.15				
	Hydraulic Pump	kW	2.25						2.25				
	Coolant Pump	kW	1.62						1.62				
	Chip Conveyor	kW	0.25						0.25				
ATC	Oil Cooler Pump	kW	3.6						3.6				
	No. of Tools	pieces	(24, 32, 40, 60)						(24, 32, 40, 60)				
	Tool Selection		Absolute						Absolute				
	Tool Change Time (approx.) (T to T)	Sec.	15						15				
	Max. Tool-Diameter / Length	mm	Ø125/Ø250 (Without Adjacent Tool) / Length 400						Ø125/Ø250 (Without Adjacent Tool) / Length 400				
	Max. Tool Weight	kg	25						25				
COOLANT & LUBRICATION	Coolant Tank Volume	L	400						400				
	Hydraulic Tank Volume	L	80						80				
	Lubrication Tank Volume	L	8						8				
MISCELLANEOUS	Power Required	kVA	55						55				
	Pressurized Air	kg/cm ²	6						6				
	Machine Weight	ton	26	29	31	37	27	31	28	29	30		

■ Specifications are subject to change without prior notice.



- Four linear ways on Z-axis (M55 roller type. Each with four blocks).
- Chip augers are mounted at both sides of Z-axis (optional)

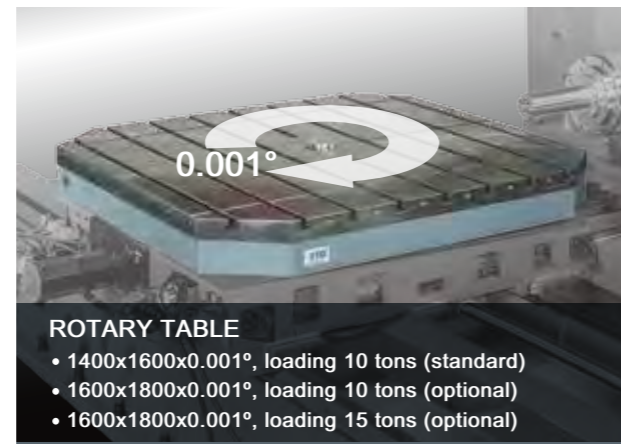

ROTARY TABLE

- 1400x1600x0.001°, loading 10 tons (standard)
- 1600x1800x0.001°, loading 10 tons (optional)
- 1600x1800x0.001°, loading 15 tons (optional)

STANDARD ACCESSORIES :

1. Spindle oil cooler
2. Automatic power off
3. Hydraulic system
4. Coolant system
5. Lubricator system
6. Alarm lamp
7. Work lamp
8. M.P.G.
9. RS232 interface
10. Heat exchanger
11. Chip conveyor and cart
12. Leveling bolts & pads
13. Controller manuals and circuit diagram
14. Operation manuals
15. Machine inspection lists
16. Toolbox with spanners & wrenches
17. FANUC OiMF
18. Splash guards
(around the operator and work table)

OPTIONAL ACCESSORIES :

1. Y-axis travel: 2000 mm
2. Z-axis travel: 1700 mm
3. Linear scale on X, Y, Z, W axes
4. ATC: 24, 32, 40, 60 Tools
5. Air conditioner at the electrical cabinet
6. Coolant through spindle
7. Large splash guards (around the machine)
8. Rotary table: 1800x1600mm/0.001°
load: 15 tons
9. Simultaneously controlled rotary table
10. Ø1650mm rotary table for turning

UMM-RWU SERIES

CNC 6-AXIS HEAVY DUTY MILLING MACHINE

- The spindle head provides -10° ~ 45° automatic swiveling function.
- Applicable for milling, drilling, tapping and boring on bevel surface.
- Multi-face workpiece can be machined with only a single setup.
- Especially ideal for bevel surface machining for the wind power parts and mold-making industries.

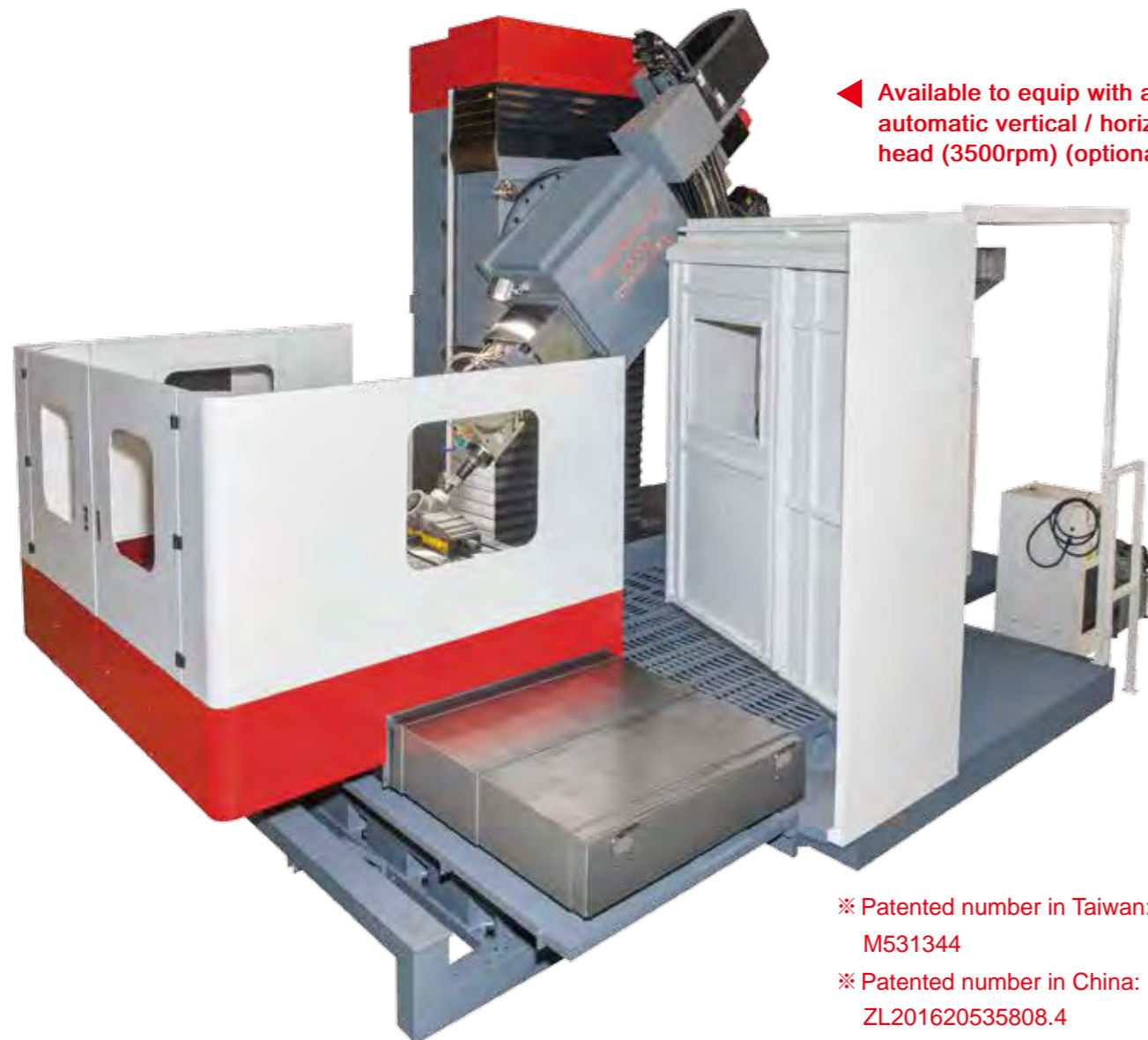

◀ Available to equip with an automatic vertical / horizontal head (3500rpm) (optional)

※ Patented number in Taiwan: M531344

※ Patented number in China: ZL201620535808.4

UMM-RWU MACHINE SPECIFICATIONS

(): As Optional

MODLE		UNIT	UMM-2017RWU	UMM-2517RWU	UMM-3217RWU	UMM-4217RWU	UMM-5217RWU
TABLE	Table Size	mm	1400 x 1600 x 0.001° (1600 x 1800 ~ 2500 x 3000)				
	T-slots Size	mm	24				
	Maximum Load	kg	8000 (10000 ~ 40000)				
TRAVEL	X-Axis	mm	2000	2500	3200	4200	5200
	Y-Axis	mm	1700 (2200, 2700, 3200)				
	Z-Axis	mm	1200 (2000, 2500)				
	W-Axis (Ram type)	mm	600 (800)				
	Angle of U-axis		-10° ~ 45°				
SPINDLE	Speed	rpm	6000 (4000)				
	Taper		7/24 Taper ISO.50, BT-50				
DISTANCES	Spindle Center to Table Surface (Spindle at horiz.)	mm	300~2000 (2500, 3000, 3500)				
	Spindle Nose to Table Center (At horiz.)	mm	200 (0) ~ 2000 (2700, 3200)				
	Height From Ground to Table Surface	mm	1250				
FEED RATE	Rapid Feed Rate X / Y / Z / W	m/min	10				
	Minimum Setting	mm	0.001				
	Cutting Feed Rate	mm/min	1~5000				
MOTOR	Spindle Servo Motor-cont. / 30min	kW	22 / 26				
	Axis X / Y / Z / W / B / U	kW	7 / 7 / 4 / 4 / 7 / 9				
	Lubricator Motor	kW	0.15				
	Hydraulic Pump	kW	2.25				
	Coolant Pump	kW	1.62				
	Chip Conveyor	kW	0.25				
	Oil Cooler Pump	kW	3.6				
ATC	No. of Tools	pieces	(24, 32, 40, 60)				
	Tool Selection		Absolute				
	Tool Change Time (approx.) (T to T)	sec	15				
	Max. Tool-Diameter / Length	mm	$\varnothing 125 / \varnothing 250$ (Without Adjacent Tool) / Length 400				
	Max. Tool Weight	kg	25				
COOLANT & LUBRICATION	Coolant Tank Volume	L	400				
	Hydraulic Tank Volume	L	80				
	Lubrication Tank Volume	L	8				
MISCELLANEOUS	Power Required	kVA	60				
	Pressurized Air	kg/cm ²	6				
	Machine Weight	ton	30	31	32	33	35

■ Specifications are subject to change without prior notice.

STANDARD ACCESSORIES :

1. Spindle oil cooler
2. Automatic power off
3. Hydraulic system
4. Coolant system
5. Lubricator system
6. Alarm lamp
7. Work lamp
8. M.P.G.
9. RS-232 interface
10. Heat exchanger
11. Chip conveyor and cart
12. Leveling bolts & pads
13. Controller manuals and circuit diagram
14. Operation manuals
15. Machine inspection lists
16. Toolbox with spanners & wrenches
17. FANUC 0iMF
18. Splash guards (around the operator and work table)

OPTIONAL ACCESSORIES :

1. Y-axis travel: 2200, 2700, 3200 mm
2. Z-axis travel: 2000, 2500 mm
3. Linear scale on X, Y, Z axes
4. ATC: 24, 32, 40, 60 Tools
5. Air conditioner at the electrical cabinet
6. Coolant through spindle
7. Large splash guards (around the machine)
8. Various rotary tables with different disk and loading capacity
9. Automatic vertical / horizontal milling head (3500rpm)
10. Various milling heads

UMM-F SERIES

FLOOR TYPE POWERFUL CNC MILLING MACHINE

- Fixed table with maximized loading capacity.
- Z-axis is a square ram type with 8 surfaces binding and powerful milling head.
- For deep hole mold machining, a flange type long nose spindle is available.
- For 3D fine machining on a mold, a square ram type spindle head with 4 linear guideways is available.
- X-axis is mounted with 4 roller type linear guideways. Y-axis is mounted with two roller type linear guideways at front and two at back.



▲ Fully enclosed splash guard (optional)

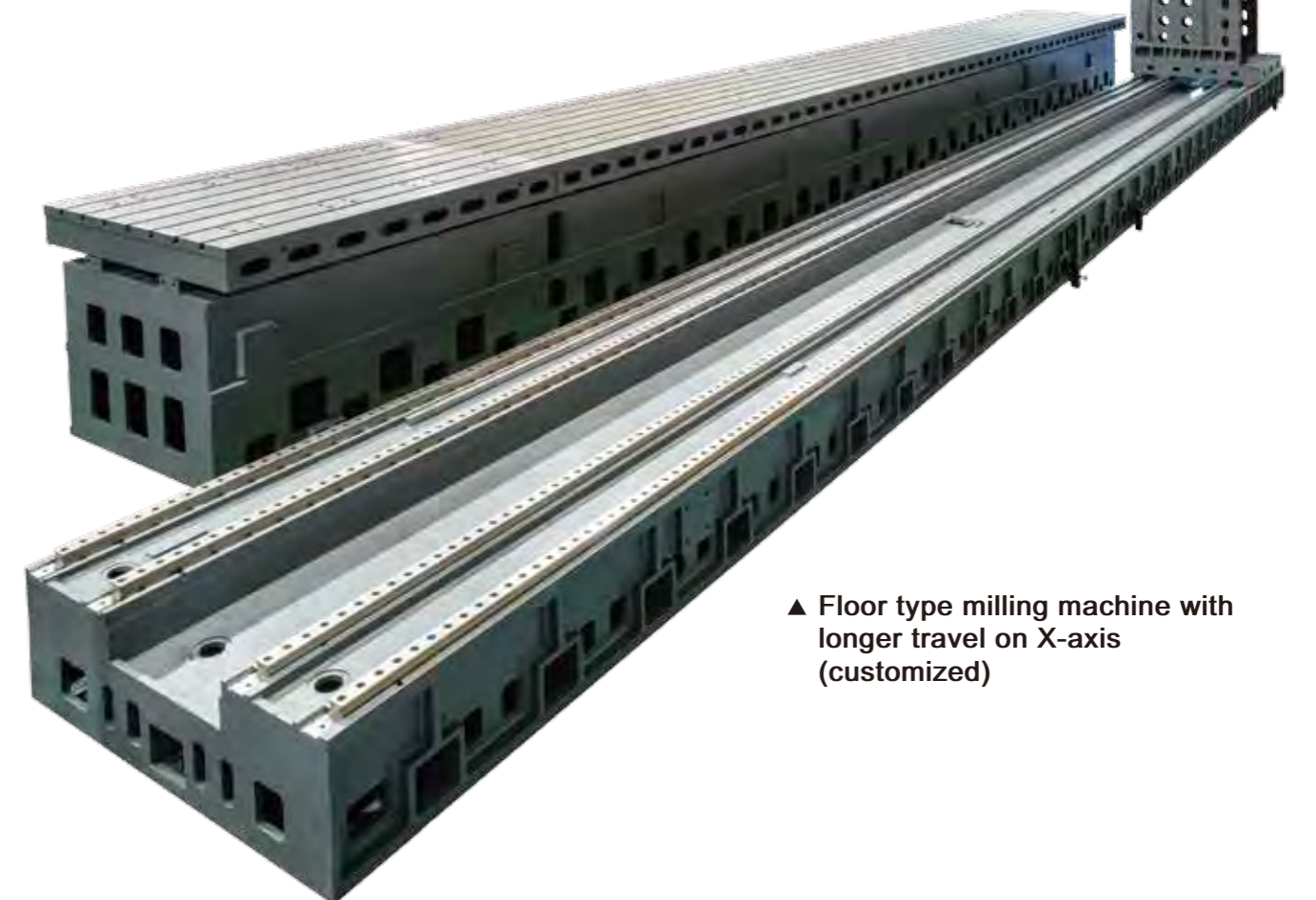

▲ Floor type milling machine with longer travel on X-axis (customized)

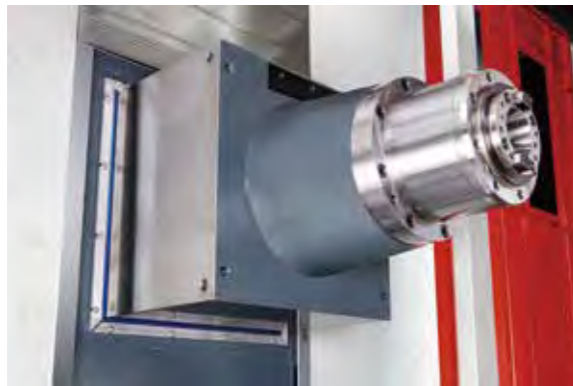

• Flange type long nose spindle (optional)



• Operation area on UMM-F series

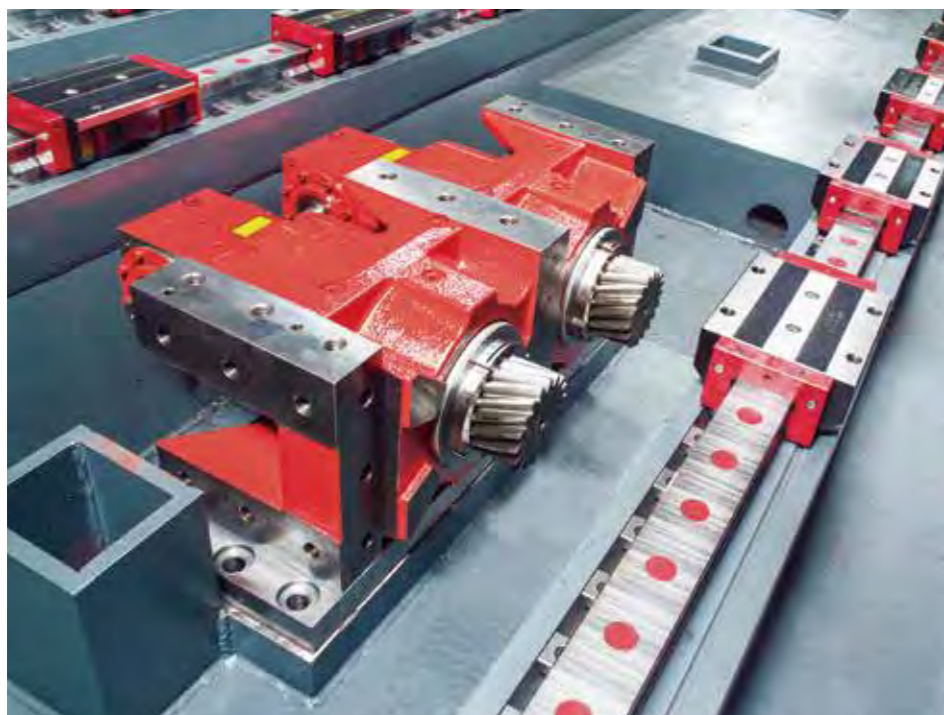

• In case X-axis travel is more than 8200mm, high precision rack and Franch REDEX gear reducer will be used.

UMM-F MACHINE SPECIFICATIONS

[]: As Optional

MODLE		UNIT	UMM-2216F	UMM-2616F	UMM-3216F	UMM-4216F	UMM-5216F	UMM-6216F
TABLE	Table Size	mm	2000x1400	2400x1400	3000x1400	4000x1400	5000x1400	6000x1400
	T-slots Size	mm	24					
	Maximum Load	kg	30000	35000	40000	45000	50000	55000
TRAVEL	X-Axis	mm	2200	2600	3200	4200	5200	6200
	Y-Axis	mm	1600 (2000)					
	Z-Axis	mm	600 (800)					
SPINDLE	Speed	rpm	6000 (4000)					
	Taper		7/24 Taper ISO.50, BT-50					
DISTANCES	Spindle Center to Table Surface	mm	250~1850 (2250)					
	Spindle Nose to Table Center	mm	200~800 (0~800)					
	Height From Ground to Table Surface	mm	1270					
FEED RATE	Rapid Feed Rate X/Y/Z	m/min	10					
	Minimum Setting	mm/min	0.001					
	Cutting Feed Rate	mm/min	1~5000					
MOTOR	Spindle Servo Motor-cont. / 30min	kW	22 / 26					
	Axis X/Y/Z	kW	7 / 4 / 4					
	Lubricator Motor	kW	0.15					
	Hydraulic Pump	kW	2.25					
	Coolant Pump	kW	1.62					
	Chip Conveyor	kW	0.25					
	Oil Cooler Pump	kW	3.6					
	No. of Tools	pieces	[24, 32, 40, 60]					
ATC	Tool Selection		Absolute					
	Tool Change Time (approx.) [T to T]	Sec.	15					
	Max. Tool-Diameter / Length	mm	Ø125/Ø250 (Without Adjacent Tool) / Length 400					
	Max. Tool Weight	kg	25					
COOLANT & LUBRICATION	Coolant Tank Volume	L	450					
	Hydraulic Tank Volume	L	80					
	Lubrication Tank Volume	L	8					
MISCELLANEOUS	Power Required	kVA	55					
	Pressurized Air	kg/cm ²	6					

■ Specifications are subject to change without prior notice.

STANDARD ACCESSORIES :

- Spindle oil cooler
- Automatic power off
- Hydraulic system
- Coolant system
- Lubricator system
- Alarm lamp
- Work lamp
- M.P.G.
- RS-232 interface
- Heat exchanger
- Chip conveyor and cart
- Leveling bolts & pads
- Controller manuals and circuit diagram
- Operation manuals
- Machine inspection lists
- Toolbox with spanners & wrenches
- FANUC 0iMF
- Splash guards
(around the operator and work table)

OPTIONAL ACCESSORIES :

- Y-axis travel: 2000 mm
- Z-axis travel: 800 mm
- X-axis travel: 7200 ~14000 mm
- Linear scale on X, Y, Z axes
- Table width 1800mm
- ATC
- Air conditioner at the electrical cabinet
- Coolant through spindle
- Large splash guards (around the machine)
- Various auxiliary tables
- Automatic vertical horizontal 90° head (3500rpm or 6000rpm)

UMM-D SERIES

CNC HORIZONTAL TWIN HEAD BORING & MILLING MACHINING CENTER SERIES

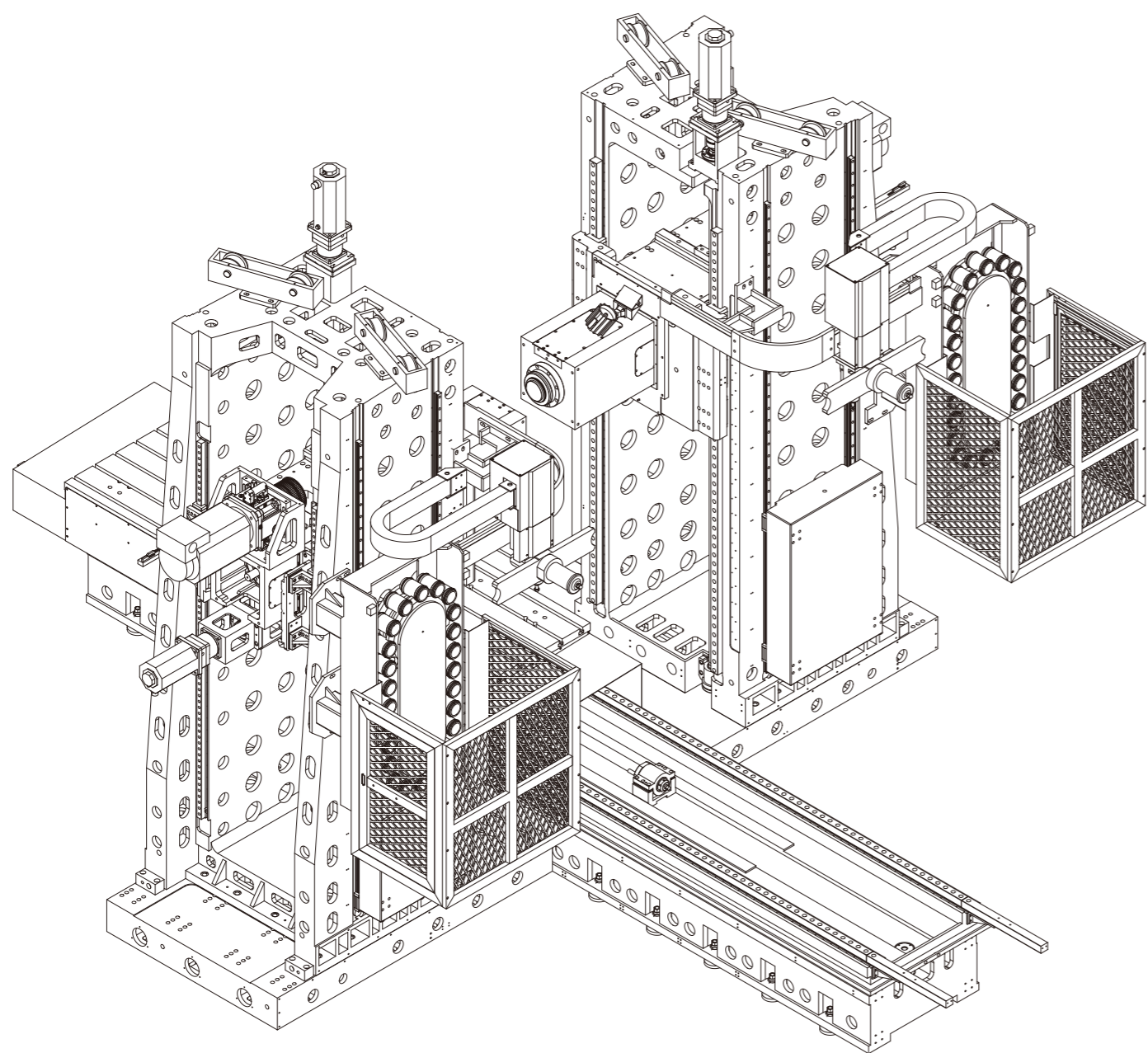

Moving table with twin head milling

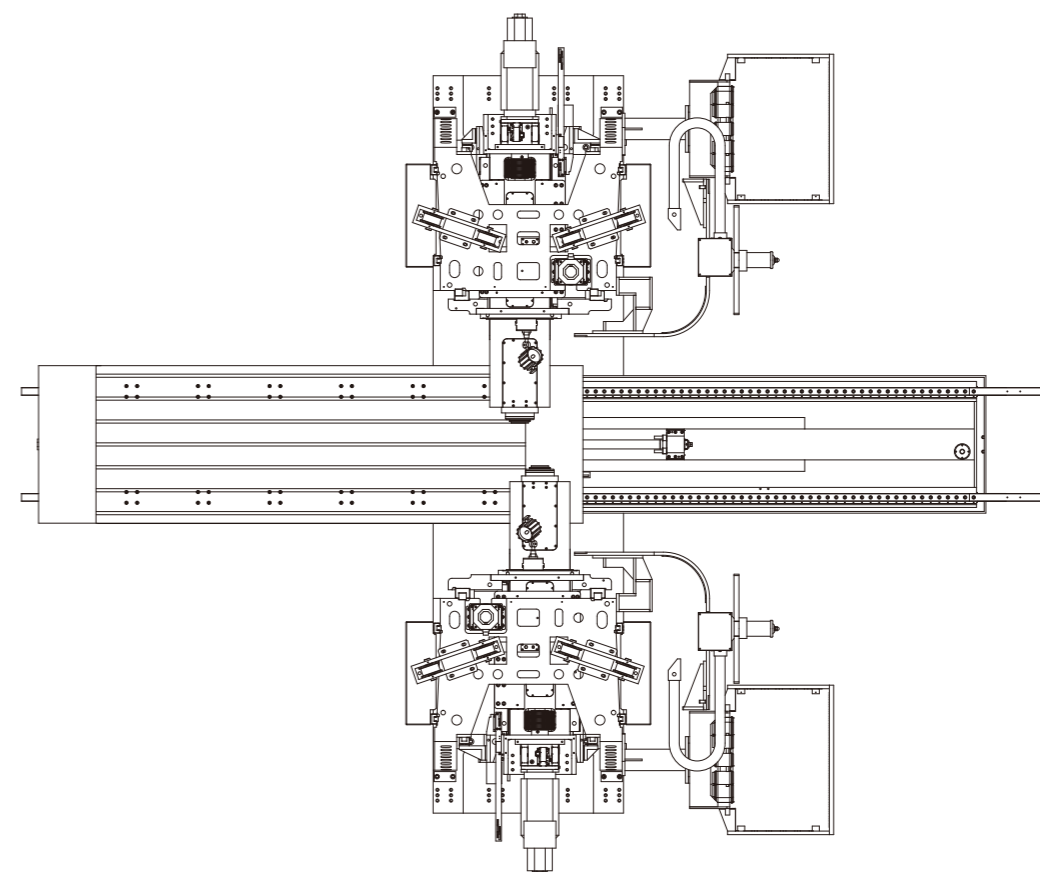
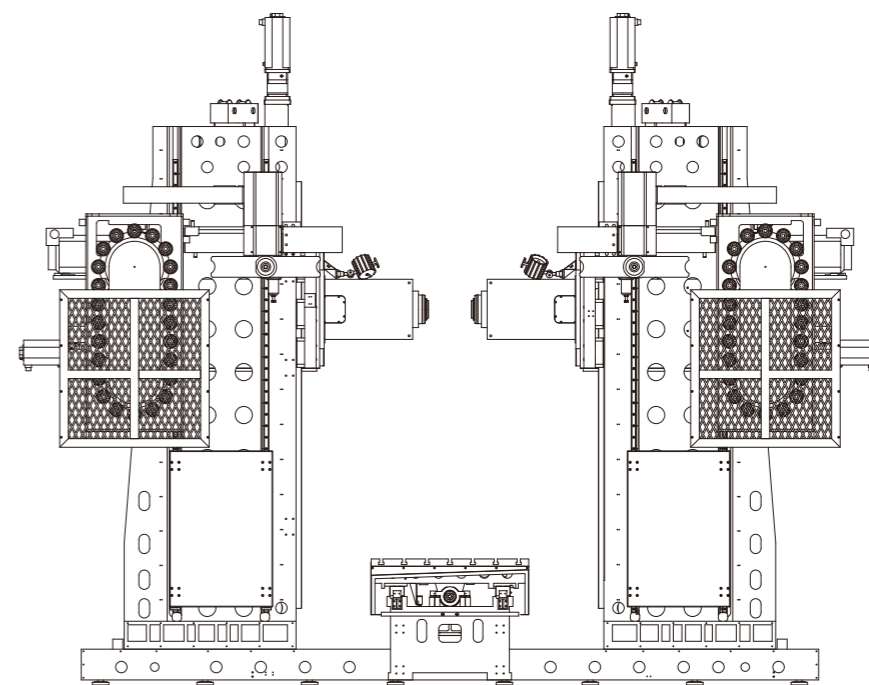

UMM-D

MACHINE SPECIFICATIONS

[] : As Optional

MODLE		UNIT	UMM-5216D	UMM-6216D	UMM-7216D	UMM-8216D	UMM-9216D
TABLE	Table Size	mm	5000 x 1000	6000 x 1000	7000 x 1000	8000 x 1000	9000 x 1000
	T-slots Size	mm	22				
	Maximum Load	kg	6000	7000	8000	9000	10000
TRAVEL	X-Axis	mm	5200	6200	7200	8200	9200
	Y1-Axis	mm	1600 [2000]				
	Y2-Axis	mm	1600 [2000]				
	Z1-Axis	mm	500 [600]				
	Z2-Axis	mm	500 [600]				
SPINDLE	Speed	rpm	4000 [6000]				
	Taper		7/24 Taper ISO.50, BT-50				
DISTANCES	Spindle Center to Table Surface	mm	210~1810 [2210]				
	Spindle Nose to Table Center	mm	150 ~ 650				
	Dist. between spindle noses	mm	300 ~ 1300				
FEED RATE	Rapid Feed Rate X / Y / Z	m/min	10 / 15 / 10				
	Minimum Setting	mm	0.001				
	Cutting Feed Rate	mm/min	1~5000				
MOTOR	Spindle Servo Motor-cont. / 30min	kW	22 / 26				
	Axis X / Y1 / Y2 / Z1 / Z2	kW	7 / 4 / 4 / 4 / 4				
	Lubricator Motor	kW	0.15				
	Hydraulic Pump	kW	3.7				
	Coolant Pump	kW	1.62				
	Chip Conveyor	kW	0.25				
COOLANT & LUBRICATION	Oil Cooler Pump	kW	3.6				
	Coolant Tank Volume	L	400				
	Hydraulic Tank Volume	L	80				
MISCELLANEOUS	Lubrication Tank Volume	L	8				
	Power Required	kVA	55				
	Pressurized Air	kg/cm ²	6				

■ Specifications are subject to change without prior notice.

STANDARD ACCESSORIES :

- Sheetmetal guard for table (flush with table)
- Spindle oil cooler
- Automatic power off
- Hydraulic system
- Coolant system
- Lubricator system
- Alarm lamp
- Work lamp
- M.P.G.
- RS-232 interface
- Chip auger, chain type chip conveyor and chip cart
- Leveling bolts & pads
- Controller manuals and circuit diagram
- Operation manuals
- Machine inspection lists
- Toolbox with spanners & wrenches
- FANUC OiMF
- Automatic power off
- Heat exchanger for electrical cabinet
- X-axis linear scale (FAGOR)

OPTIONAL ACCESSORIES :

- Table width 1200, 1400mm
- Y1, Y2-axis travel 2000mm
- Z1, Z2-axis travel 600mm
- Flange type long nose spindle
- Linear scale on Y, Z-axis
- Tool magazine (24, 32, 40 tools)
- X-axis travel over 10M. Twin traveling column, twin system
- Milling head changed to boring head (boring har diameter 110mm or 130mm)
- Other control systems



Twin traveling column horizontal twin head boring and milling machining center (customized) (X-axis travel more than 10M should be customized).