

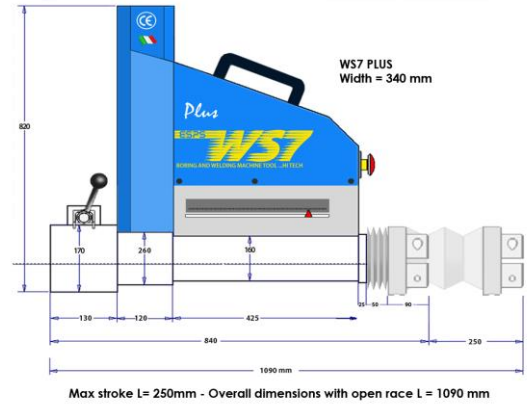

WS7 Plus from \varnothing 400 mm to \varnothing 1700 mm

IN LINE BORING	FROM \varnothing 400 MM TO \varnothing 1700 MM
INTERNAL WELDING	FROM \varnothing 400 MM TO \varnothing 1700 MM
EXTERNAL WELDING	FROM \varnothing 20 MM TO \varnothing 250 MM

Ex works



1	DRIVE UNIT WS7 PLUS	1	31	COMPARATOR 1/100	4
2	CONTROL PANEL	1	32	COMPARATOR EXTENSION	1
3	CONTROL PANEL CABLE	1	33 (A)	COMPARATOR HOLDER 8/8	1
4	CONTROL PANEL COMPLETE SUPPORT	1	33 (B)	COMPARATOR HOLDER 10/8	1
5 (A)	CONNECTABLE SHAFTS \varnothing 100 MM, LENGTH 1135 MM	1	34	COMPLETE TORCH CABLE	1
5 (B)	CONNECTABLE SHAFTS \varnothing 100 MM, LENGTH 2000 MM	1	35	TORCH SHAFT \varnothing 60 MM - TOTAL LENGTH 2000 MM	1
6	COMPLETE SUPPORT	2	36 (A)	REDUCTION BUSHING FOR FRONT TORCH SHAFT LENGTH 240	1
7 (A)	ADJUSTMENT BRACKETS FOR DIAMETERS N° 12 X MM 200	12	36 (B)	REDUCTION BUSHING FOR POSTERIOR TORCH SHAFT LENGTH 150	1
7 (B)	ADJUSTMENT BRACKETS FOR DIAMETERS N° 12 X mm 300	12	37	LONG GAS NOZZLE	1
5 (C)	ADJUSTMENT BRACKETS FOR DIAMETERS N° 10 X mm 850	10	38	LONG COPPER WIRE NOZZLE \varnothing 1,2 MM	1
8	STAR SHAPED SUPPORT WITH 5 ENDS DIAMETER 920 MM -	2	39	LONG COPPER WIRE NOZZLE \varnothing 1,6 MM	2
9	STAR WASHERS FOR FIXING BRACKETS	20			
10	BRACKET COLUMN	10			
11	SPACER COLUMN	10			
12	NUT COLUMN	10			
13	18 WASHERS COMPLETE WITH BOLTS	20	40	SERVICE WRENCHES (COMPOSED OF: HEX WRENCH \varnothing 3 HEX WRENCH \varnothing 4 HEX WRENCH \varnothing 5 HEX WRENCH \varnothing 6 HEX WRENCH "L" \varnothing 12 COMBINED WRENCH - \varnothing 22	1
14	CENTERING KIT (2 EXTERNAL RINGS-2 INTERNAL RINGS- 6 CENTERING BOSSES 100MM LENGTH)	1			
15	CENTERING THREADED BARS (6 - M30X200 MM; 6 - M30X400 MM; 6 - M30X600 MM; 6 - M30 X 800 MM)	24			
16	INSERTS	10			
17	TOOL HOLDER INSERT S10CX35 MM	1	41	TROLLEY	1
18	TOOL HOLDER INSERT S10CX50 MM	1	42	SHAFT HOLDER	1
19	TOOL HOLDER INSERT S12CX80 MM	1	43	MORSE TAPER EXTRACTOR	1
19(A)	TORX WRENCH FOR INSERT	1	44	SUPPORT EXPANSION COMPLETE WITH EXTENSIONS	1
20	MAIN DISK TOOL HOLDER \varnothing 340 MM COMPOSED OF 2 HALF DISK	1			
21	TOWER SHAPED EXTENSION 100MM HEIGTH FOR MAIN TOOL HOLDER	2			
22	SUPPLEMENT 50MM HEIGTH FOR TOOL HOLDER EXTENSION	4			
23	SUPPLEMENT 100MM HEIGTH FOR TOOL HOLDER EXTENSION	4			
24	SUPPLEMENT 200MM HEIGTH FOR TOOL HOLDER EXTENSION	2			
25	CHROMED BARS \varnothing 40 X 50 MM FOR TOOL HOLDER EXTENSION	2			
26	CHROMED BARS \varnothing 40 X 100 MM FOR TOOL HOLDER EXTENSION	2			
27	CHROMED BARS \varnothing 40 X 150 MM FOR TOOL HOLDER EXTENSION	2			
28	THREADED BARS M14	88			
29	MICROSPAND (MODULAR DEVICE USED FOR INTERNAL MEASUREMENTS)	1			
30	MICROSPAND EXTENSION 100 MM	4			

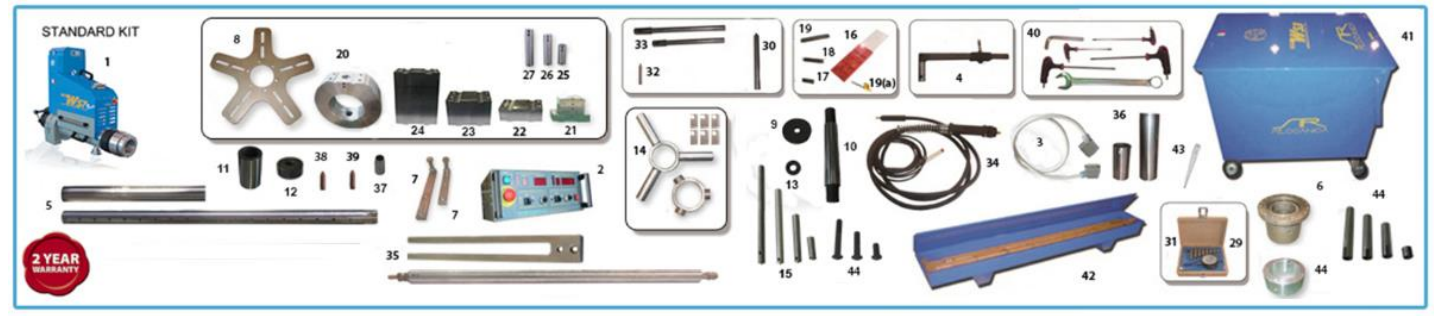

COMMERCIAL CONDITIONS:

DELIVERY: PROMPT
 PACKING: FREE N° 1 METAL BOX (TROLLEY)
 WARRANTY: 24 MONTHS



CERTIFIED TEST

DIAMETER	mm	\varnothing 800	\varnothing 1700
CUTTING DEPTH	mm	4 IN RADIUS 8 IN DIAMETER	1,5 IN RADIUS 3 IN DIAMETER
FEED SPEED	mm/min.	5	2