

22"/32" bed Heavy Duty Oil Country Lathe

Description \ Model	FEL-3800	FEL-4200	FEL-4700	FEL-5500	FEL-6300	
Center height 中心高度	480 mm	530 mm	600 mm	700 mm	800 mm	
Swing over bed 床面旋徑	960 mm (38")	1060 mm (42")	1200 mm (47")	1400 mm (55")	1600 mm (63")	
Swing over cross slide 鞍上旋徑	650 mm	750 mm	830 mm	1030 mm	1230 mm	
Swing over gap 凹凸旋徑	1510 mm	1610 mm	1750 mm	1950 mm	2150 mm	
Width of gap 凹凸寬度	570 mm (No gap if Distance between centers is longer than 5m)		600 mm			
Width of bed 床身寬度	560 mm (22")		800 mm (32")			
Distance between centers 兩心間距離	2000-9000 mm (80-360")		2000-14000 mm (80-560") in one piece			
Spindle bore 主軸孔徑	Ø156 mm (22" bed)	Ø230 mm	Ø260 mm	Ø310 mm	Ø360 mm	Ø535 mm (32" bed)
Spindle nose 主軸鼻端	A2-11	A2-15	A2-15	A2-20	A2-20	A2-28
Spindle speeds (12 Steps) 主軸轉速(12段)	9-600	6-400	6-400	5-300	5-300	3-230
Tailstock quill diameter 尾座心軸	Ø125 mm		Ø200 mm (Ø290 mm Rotary Quill for Option)			
Taper of center 心軸斜度	MT#6		MT#7			
Quill travel 尾座心軸行程	300 mm		300 mm			
Cross feeds 橫向進給	0.065-0.96 (48 Kinds)		0.065-0.96 (48 Kinds)			
Cross travel 橫向行程	540 mm		780 mm			
Compound rest travel 複式刀座行程	300 mm		350 mm			
Tool size 刀具尺寸	40 x 40 mm		50 x 50 mm			
Longitudinal feeds 縱向進給	0.13-1.92 (48 Kinds)		0.13-1.92 (48 Kinds)			
Lead screw diameter 導螺桿直徑	Ø50 mm x 2 TPI		Ø50 mm x 2 TPI			
Threading range, metric 公制車牙範圍	2-30 mm/Pitch (48 Kinds)		2-30 mm/Pitch (48 Kinds)			
Threading range, inch 英制車牙範圍	1-15 TPI (48 Kinds)		1-15 TPI (48 Kinds)			
Module pitch threads 模數螺紋	1-15 M (32 Kinds)		1-15 M (32 Kinds)			
DP, pitch threads 徑節螺紋	2-30 P (48 Kinds)		2-30 P (48 Kinds)			
Main spindle motor 主驅動馬達	20 HP (30 HP for Option)		30 HP (40 HP or 50 HP for Option)			
Rapid motor 快送馬達	1/2 HP		1 HP			
Coolant pump 冷卻泵浦	1/4 HP		1/4 HP			
Oil pump 潤滑泵浦	12 W		12 W			

*本公司備有設計變更及規格變更之權力，若有變更恕不另行通知。
*Specifications are subject to change without notice for further design improvement.

52" bed Giant Heavy Duty Lathe

Description \ Model	FEL-7000	FEL-8000	FEL-10000
Center height 中心高度	900 mm	1000 mm	1250 mm
Swing over bed 床面旋徑	1800 mm (70")	2000 mm (80")	2500 mm (100")
Swing over cross slide 鞍上旋徑	1350 mm	1550 mm	2050 mm
Width of bed 床身寬度	1320 mm (4 Guide Way)		
Distance between centers 兩心間距離	3000 mm ~ 20000 mm (120~480") in One Piece		
Spindle bore diameter 主軸孔徑	Ø230 mm		
Spindle bore nose 主軸鼻端	A 2- 15		
Spindle speed(4 Steps) 主軸轉速(4段)	6 ~400		
Tailstock quill diameter 尾座心軸	Ø290mm Heavy Duty Live Tailstock		
Taper of center 心軸斜度	MT#7		
Quill travel 尾座心軸行程	300 mm		
Cross feeds 橫向進給	0.056-0.96 (48 kinds)		
Cross travel 橫向行程	1230 mm		
Compound rest travel 複式刀座行程	400mm (Auto Feeding)		
Tool size 刀具尺寸	50 X 50 mm		
Longitudinal feeds 縱向進給	0.13-1.92 (48 kinds)		
Lead screw diameter 導螺桿直徑	Ø60 mm X 2 TPI		
Threading range, metric 公制車牙範圍	2-30 mm / Pitch (48 Kinds)		
Threading range, inch 英制車牙範圍	1-15 TPI (48 Kinds)		
Module pitch threads 模數螺紋	1-15 m (32 Kinds)		
DP, pitch threads 徑節螺紋	2-30 mm (48 Kinds)		
Main spindle motor 主驅動馬達	60 HP (75 HP is Optional Accessory)		
Rapid motor 快送馬達	2 HP		
Coolant pump 冷卻泵浦	1 HP		
Lubrication pump 潤滑泵浦	12 W		
Machine weight (3 meter D.B) 機器重量(3米)	28000 kg	29000 kg	30500 kg
Weight per extra meter 每加1米長	4500 kg		

* THE SPECIFICATIONS ARE SUBJECT TO CHANGE WITHOUT PRIOR NOTICE.

*本公司備有設計變更及規格變更之權力，若有變更恕不另行通知。
*Specifications are subject to change without notice for further design improvement.



Large Spindle Bore for Oil Country

LARGE HEAVY DUTY LATHE

重切削巨型車床

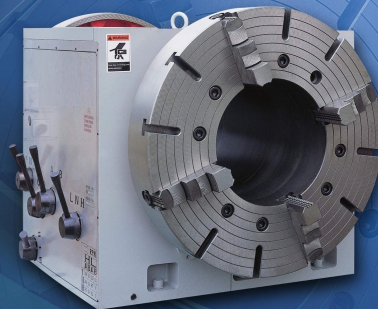

Large Spindle Bore for Oil Country

LARGE HEAVY DUTY LATHE

重切削巨型車床



◆ 6-Way Rapid Traverse
六向快速自動進給



◆ Tailstock Rotary Quill
Motor for Tailstock Movement
尾座迴轉心軸
尾座移動馬達

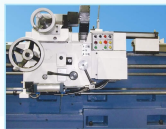

◆ Auto Rapid Threading Device
自動式快速車牙裝置



◆ Pin-locking type 4-way tool post
ensures safety in cutting and is easy
to swivel forward and reversely.
插銷式四方刀架，可確保四方刀架反
向切向時滑動以確保安全，且方便正
反向轉動。



◆ Double Chuck
雙夾頭



◆ HD Steady Rest
滾輪座

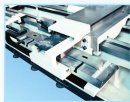

◆ Taper Attachment
斜度附件

22"/32" STANDARD ACCESSORIES / 標準配件

- | | |
|---|--|
| <ul style="list-style-type: none"> ● Main Motor ● Spindle Magnetic Brake ● Auto Lubrication System ● Coolant System ● 4-Way Tool Post ● X-Z Axes Rapid Traverse ● Meter / Inch Community Gear Box ● Guide Way Hardened, Grinder & Wiper ● Tailstock Center ● Tool Box with Tools ● Leveling Bolts & Pads ● Operation & Service Manual | <ul style="list-style-type: none"> ● 主軸馬達 ● 主軸電磁剎 ● 自動潤滑系統 ● 冷卻系統 ● 四方刀架 ● X-Z軸快速 ● 公制/英制共用齒輪箱 ● 床面硬化、研磨 ● 尾座頂針 ● 工作箱含工具 ● 水平螺絲及墊片 ● 操作及維修手冊 |
|---|--|

52" STANDARD ACCESSORIES / 標準配件

- | | |
|--|--|
| <ul style="list-style-type: none"> ● Main Motor with Inverter ● Hydraulic Spindle Disk Brake ● Auto Lubrication System ● Coolant System ● 4-way Tool Post ● Leveling Bolts & Pads ● 6-way Rapid Traverse ● Metric / Inch Community Gear Box ● Tailstock Dead Center ● Tailstock Rotary Quill Ø290mm ● Motor-driven Tailstock ● Tool Box with Tools ● Operation & Service Manual | <ul style="list-style-type: none"> ● 主軸馬達含變頻器 ● 主軸油壓碟剎 ● 自動潤滑系統 ● 冷卻系統 ● 四方刀架 ● 水平螺絲及墊片 ● 六向快速自動進給 ● 公制/英制共用齒輪箱 ● 尾座固定頂針 ● 尾座旋轉心軸Ø290mm ● 馬達驅動移動尾座 ● 工作箱含工具 ● 操作及維修手冊 |
|--|--|

22"/32" OPTIONAL ACCESSORIES / 選購配件

- | | |
|---|--|
| <ul style="list-style-type: none"> ● 3-Jaw Chuck ● 4-Jaw Chuck ● 4-Jaw Face Plate ● Double Chuck System ● Steady Rest ● Follow Rest ● Rear Supporting Stand ● Quick Change Tool Post ● Rear Tool Post ● Boring Device ● Taper attachment ● Hydraulic Copy Device ● 6-way Rapid Traverse ● Auto Rapid Threading Device ● Digital Readout ● Rotary Center ● Electrical System for CE ● Work Light | <ul style="list-style-type: none"> ● 3爪夾頭 ● 4爪夾頭 ● 四爪花盤 ● 雙夾頭系統 ● 中心架 ● 跟刀架 ● 後支撐架 ● 快換刀架 ● 後刀架 ● 鏜孔設備 ● 斜度附件 ● 油壓仿削裝置 ● 六向快速自動進給 ● 自動快速車牙裝置 ● 光學尺 ● 旋轉頂針 ● CE電器系統 ● 工作燈 |
|---|--|

52" OPTIONAL ACCESSORIES / 選購配件

- | | |
|--|--|
| <ul style="list-style-type: none"> ● 3-Jaw Chuck ● 4-Jaw Chuck ● 4-Jaw Face Plate ● Steady Rest ● Boring Device ● Taper Attachment ● Hydraulic Copy Device ● Digital Readout | <ul style="list-style-type: none"> ● 三爪夾頭 ● 四爪夾頭 ● 四爪花盤 ● 中心架 ● 鏜孔設備 ● 斜度附件 ● 油壓仿削裝置 ● 光學尺 |
|--|--|

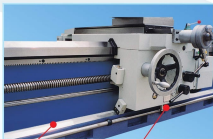
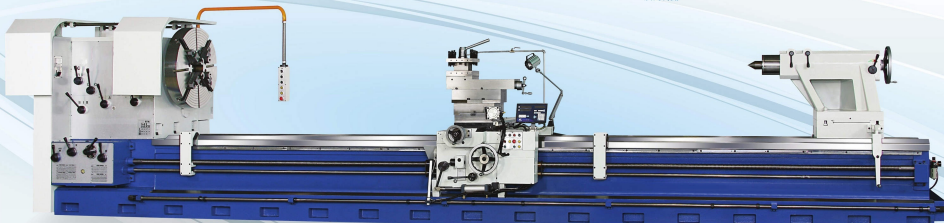

◆ The 3rd rail enhances the
cutting force.
第三支撐面，增加切削強度

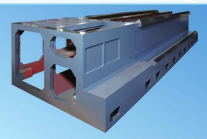

◆ Longitudinal Stop Device
自動定寸切削裝置



◆ 4-giant-way type bed for Giant Lathe
超巨型車床4軌床身



◆ Hydraulic Copy Device
(Templates are made by customers)
油壓仿削裝置



◆ Steady Rest
中心架

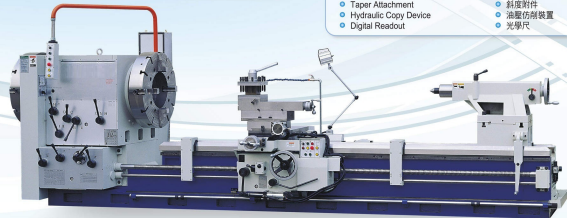

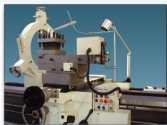

▶ 六向自動送料
6 Direction Delivery Quickly



▶ 尾座迴轉心軸
Rotary Center for Tailstock Quill

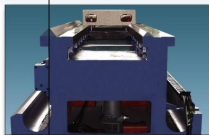

▶ 尾座移動馬達
Motor for Tailstock Movement



▶ 雙夾頭 Double Chuck.

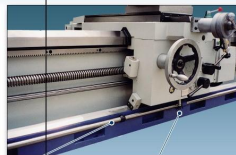

▶ 第三支撐面，增強大工件
切削強度 The 3rd rail enhance the
cutting force. ▶ 自動定寸切削裝置
Longitudinal Stop
Device.



▶ 四方刀架為插掛式，可防止四方刀架反
向切削時滑動以確保安全，正反向轉動
方便
Pin-Locking Type 4-way Tool post, easy
in forward and Reverse swiveling, also
ensure the safety in cutting.



32" Bed

標準 附件	STANDARD ACCESSORIES
主馬達	Main Motor
自動潤滑系統	Auto - Lubrication System
冷卻系統	Coolant System
四方刀架	4-Way Tool Post
X, Z軸快速	X, Z Axes Rapid Traverse
公英制兩用齒輪箱	Meter / Inch Community Gear Box
電磁剎車	Magnetic Brake
床面硬化、研磨	Guide Way Hardened, Grinder, & Wiper
尾座頂針	Tailstock Center
操作維修手冊	Operation Service Manual
工具箱	Tool Box
水平螺絲、墊塊	Leveling Bolts & Pads

選購 配件	OPTIONAL ACCESSORIES
3爪夾頭	3 - Jaw Chuck
4爪夾頭	4 - Jaw Chuck
雙夾頭系統	Double Chuck System
4爪花盤	4 - Jaw Face Plate
中包架	Steady Rest
跟刀架	Follow Rest
後支撐架	Rear Supporting Stand
快速刀架	Quick Change Tool Post
後刀架	Rear Tool Post
鑽孔座	Boring Device
斜度附件	Taper Attachment
氣動快速車牙裝置	Pneumatic Rapid Threading Device
光學尺	Digital Readout



▶ 氣動式快速車牙裝置
Pneumatic Rapid Threading
Device.



▶ 斜度附件
Taper Attachment.



▶ 中心架
Steady Rest.



▶ 滾輪座
HD Steady Rest

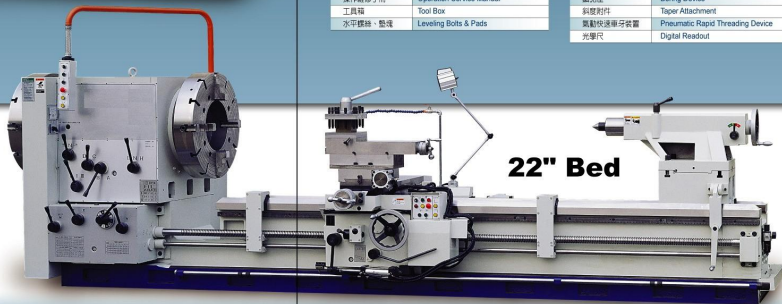

22" Bed